



General Instructions & Notices

- Applicants are directed to "**Regional Fire Services Training Facilities Grant Program Policy**" as amended for the current funding year which is incorporated by reference to all applications and any subsequent awards. (Such practices document is inclusive of all *terms & conditions*.)
- The filing of an application does not bind the Board to award nor the Department to pay any such grant.
- Incomplete applications and those received after the deadline will not be considered.
(Deadline) → **March 1, 2016** postmarked
- Completed applications executed by the competent authority will only be accepted directly from jurisdictions not fire departments.
- Timeliness of filing and subsequent receipt by the Agency are solely the applicant's responsibility – all applications must be completed in ink and sent directly to: **VDFP Grants and Local Aid Manager,**
Address → 1005 Technology Park Drive, Glen Allen VA 23059-4500
- All decisions regarding grant awards made by the Board are final; applicants may appeal decisions in writing to the address provided above within 15 business days of the posting of awards.

A. Applicant Information

1. Title of Lead Jurisdiction Making Application (Check <input checked="" type="checkbox"/> only one, then make entry)	<input type="checkbox"/>	County of	
	<input checked="" type="checkbox"/>	City of	Newport News
	<input type="checkbox"/>	Incorporated Town of	
2. Employer Identification Number (EIN)	[REDACTED]		
3. Principal Point of Contact	(Include salutation, name & title.) Mr. Robert O. Craft Jr., Assistant Fire Chief - Training		
4. Mailing Address (Include zip code) Identify COUNTY if appropriate	17300 Warwick Blvd Newport News, VA 23603		
5. Telephone Number	(757)	969-1800	
6. FAX Number	(757)	969-1844	
7. Internet e-mail address	rcraft@nnva.gov		

B. Additional Parties

	Identify ALL jurisdictions (Not Fire Departments) participating in the proposed project. Attach additional sheets as may be required.
1. Formal Agreement Among Parties	<p>In accordance with Program Policy, multi-jurisdictional regional training partnerships must be documented (e.g. MOA, MOU, etc.) as required supporting documentation to the Application for consideration of Program funding.</p> <p>A copy of the Agreement has been attached to this application. <input checked="" type="checkbox"/> Yes <input type="checkbox"/> No</p> <p><i>If a copy of the Agreement has not been attached as required supporting documentation, this Application will be considered incomplete and funding will not be approved.</i></p>

Department of Fire Programs

MAR 02 2016

Administration



{ Reproduce and complete as many additional blocs as may be necessary for complete disclosure. }

2a. Complete <u>one each</u> for ALL other Parties of Interest	Number <u>2</u> of a total of <u>7</u> parties to proposed project <small>(Count the LEAD Locality as #1, thereby start with #2.)</small>									
2b. Title of Jurisdiction <small>(Check <input checked="" type="checkbox"/> only one, then make</small>	<table border="1"> <tr> <td><input type="checkbox"/></td> <td>County of</td> <td></td> </tr> <tr> <td><input checked="" type="checkbox"/></td> <td>City of</td> <td>Hampton</td> </tr> <tr> <td><input type="checkbox"/></td> <td>Incorporated Town of</td> <td></td> </tr> </table>	<input type="checkbox"/>	County of		<input checked="" type="checkbox"/>	City of	Hampton	<input type="checkbox"/>	Incorporated Town of	
<input type="checkbox"/>	County of									
<input checked="" type="checkbox"/>	City of	Hampton								
<input type="checkbox"/>	Incorporated Town of									
2c. Employer Identification Number (EIN)	[REDACTED]									
2d. Principal Point of Contact	(Include salutation, name & title.) Mr. David Layman, Fire Chief									
2e. Mailing Address <small>Identify COUNTY if appropriate -</small>	(Include zip code+4) 22 Lincoln Street Hampton, VA 23669									
2f. Telephone Number	(757) 727-6580									
2g. FAX Number	(757) 727-6094									
2h. Internet e-mail address	dlayman@hampton.gov									

Administration

MAR 02 2016

Department of Fire Programs

{ Reproduce and complete as many additional blocs as may be necessary for complete disclosure. }

2a. Complete <u>one each</u> for ALL other Parties of Interest	Number <u>3</u> of a total of <u>7</u> parties to proposed project <small>(Count the LEAD Locality as #1, thereby start with #2.)</small>									
2b. Title of Jurisdiction <small>(Check <input checked="" type="checkbox"/> only one, then make</small>	<table border="1"> <tr> <td><input checked="" type="checkbox"/></td> <td>County of</td> <td>James City</td> </tr> <tr> <td><input type="checkbox"/></td> <td>City of</td> <td></td> </tr> <tr> <td><input type="checkbox"/></td> <td>Incorporated Town of</td> <td></td> </tr> </table>	<input checked="" type="checkbox"/>	County of	James City	<input type="checkbox"/>	City of		<input type="checkbox"/>	Incorporated Town of	
<input checked="" type="checkbox"/>	County of	James City								
<input type="checkbox"/>	City of									
<input type="checkbox"/>	Incorporated Town of									
2c. Employer Identification Number (EIN)	[REDACTED]									
2d. Principal Point of Contact	(Include salutation, name & title.) Mr. Ryan Ashe, Fire Chief									
2e. Mailing Address <small>Identify COUNTY if appropriate -</small>	(Include zip code+4) 5077 John Tyler Highway Williamsburg, VA 23185									
2f. Telephone Number	(##) 220-0626									
2g. FAX Number	(757) 220-9125									
2h. Internet e-mail address	ryan.ashe@jamescitycountyva.gov									

{ Reproduce and complete as many additional blocs as may be necessary for complete disclosure. }

2a. Complete <u>one each</u> for ALL other Parties of Interest	Number <u>4</u> of a total of <u>7</u> parties to proposed project <small>(Count the LEAD Locality as #1, thereby start with #2.)</small>									
2b. Title of Jurisdiction <small>(Check <input checked="" type="checkbox"/> only one, then make</small>	<table border="1"> <tr> <td><input type="checkbox"/></td> <td>County of</td> <td></td> </tr> <tr> <td><input checked="" type="checkbox"/></td> <td>City of</td> <td>Williamsburg</td> </tr> <tr> <td><input type="checkbox"/></td> <td>Incorporated Town of</td> <td></td> </tr> </table>	<input type="checkbox"/>	County of		<input checked="" type="checkbox"/>	City of	Williamsburg	<input type="checkbox"/>	Incorporated Town of	
<input type="checkbox"/>	County of									
<input checked="" type="checkbox"/>	City of	Williamsburg								
<input type="checkbox"/>	Incorporated Town of									
2c. Employer Identification Number (EIN)	[REDACTED]									
2d. Principal Point of Contact	(Include salutation, name & title.) Mr. W. Pat Dent, Fire Chief									
2e. Mailing Address <small>Identify COUNTY if appropriate -</small>	(Include zip code+4) 412 N. Boundary Street Williamsburg, VA 23185									
2f. Telephone Number	(757) 220-6220									
2g. FAX Number	(757) 220-6229									
2h. Internet e-mail address	wdent@williamsburgva.gov									



{ Reproduce and complete as many additional blocs as may be necessary for complete disclosure. }

2a. Complete <u>one each</u> for ALL other Parties of Interest	Number <u>5</u> of a total of <u>7</u> parties to proposed project <small>(Count the LEAD Locality as #1, thereby start with #2.)</small>						
2b. Title of Jurisdiction <small>(Check <input checked="" type="checkbox"/> only one, then make</small>	<table border="1"> <tr> <td><input checked="" type="checkbox"/></td> <td>County of <u>York</u></td> </tr> <tr> <td><input type="checkbox"/></td> <td>City of _____</td> </tr> <tr> <td><input type="checkbox"/></td> <td>Incorporated Town of _____</td> </tr> </table>	<input checked="" type="checkbox"/>	County of <u>York</u>	<input type="checkbox"/>	City of _____	<input type="checkbox"/>	Incorporated Town of _____
<input checked="" type="checkbox"/>	County of <u>York</u>						
<input type="checkbox"/>	City of _____						
<input type="checkbox"/>	Incorporated Town of _____						
2c. Employer Identification Number (EIN)	[REDACTED]						
2d. Principal Point of Contact	<small>(Include salutation, name & title.)</small> Mr. Stephen Kopczynski, Fire Chief						
2e. Mailing Address <small>Identify COUNTY if appropriate -</small>	<small>(Include zip code+4)</small> 301 Goodwin Neck Road Yorktown, VA 23602 York						
2f. Telephone Number	(757) 890-3600						
2g. FAX Number	(757) 890-3609						
2h. Internet e-mail address	kopczyns@yorkcounty.gov						

Administration
MAR 02 2016

{ Reproduce and complete as many additional blocs as may be necessary for complete disclosure. }

2a. Complete <u>one each</u> for ALL other Parties of Interest	Number <u>6</u> of a total of <u>7</u> parties to proposed project <small>(Count the LEAD Locality as #1, thereby start with #2.)</small>						
2b. Title of Jurisdiction <small>(Check <input checked="" type="checkbox"/> only one, then make</small>	<table border="1"> <tr> <td><input checked="" type="checkbox"/></td> <td>County of _____</td> </tr> <tr> <td><input checked="" type="checkbox"/></td> <td>City of <u>Poquoson</u></td> </tr> <tr> <td><input type="checkbox"/></td> <td>Incorporated Town of _____</td> </tr> </table>	<input checked="" type="checkbox"/>	County of _____	<input checked="" type="checkbox"/>	City of <u>Poquoson</u>	<input type="checkbox"/>	Incorporated Town of _____
<input checked="" type="checkbox"/>	County of _____						
<input checked="" type="checkbox"/>	City of <u>Poquoson</u>						
<input type="checkbox"/>	Incorporated Town of _____						
2c. Employer Identification Number (EIN)	[REDACTED]						
2d. Principal Point of Contact	<small>(Include salutation, name & title.)</small> Mr. Robert Holloway, Fire Chief						
2e. Mailing Address <small>Identify COUNTY if appropriate -</small>	<small>(Include zip code+4)</small> 830 Poquoson Avenue Poquoson, VA 23662						
2f. Telephone Number	(##) 868-3510						
2g. FAX Number	(757) 868-3514						
2h. Internet e-mail address	rholloway@poquoson-va.gov						

{ Reproduce and complete as many additional blocs as may be necessary for complete disclosure. }

2a. Complete <u>one each</u> for ALL other Parties of Interest	Number <u>7</u> of a total of <u>7</u> parties to proposed project <small>(Count the LEAD Locality as #1, thereby start with #2.)</small>						
2b. Title of Jurisdiction <small>(Check <input checked="" type="checkbox"/> only one, then make</small>	<table border="1"> <tr> <td><input checked="" type="checkbox"/></td> <td>County of <u>U. S. Army Transportation Base - Ft. Eustis</u></td> </tr> <tr> <td><input type="checkbox"/></td> <td>City of _____</td> </tr> <tr> <td><input type="checkbox"/></td> <td>Incorporated Town of _____</td> </tr> </table>	<input checked="" type="checkbox"/>	County of <u>U. S. Army Transportation Base - Ft. Eustis</u>	<input type="checkbox"/>	City of _____	<input type="checkbox"/>	Incorporated Town of _____
<input checked="" type="checkbox"/>	County of <u>U. S. Army Transportation Base - Ft. Eustis</u>						
<input type="checkbox"/>	City of _____						
<input type="checkbox"/>	Incorporated Town of _____						
2c. Employer Identification Number (EIN)	[REDACTED]						
2d. Principal Point of Contact	<small>(Include salutation, name & title.)</small> Mr. Dale Hankins, Fire Chief						
2e. Mailing Address <small>Identify COUNTY if appropriate -</small>	<small>(Include zip code+4)</small> Building 648 Jackson Avenue Ft Eustis, VA 23604						
2f. Telephone Number	(757) 878-4281						
2g. FAX Number	(757) 878-3592						
2h. Internet e-mail address	dale.e.hankins.civ@mail.mil						



C. Previous Applications/Awards

1.	Has the Applicant previously applied for a RFSTF Grant from the Board? - <i>check <input checked="" type="checkbox"/> one</i>	<input type="checkbox"/> No	<input checked="" type="checkbox"/> Yes
2.	Has the Applicant previously received a RFSTF Grant from the Board? - <i>check <input checked="" type="checkbox"/> one</i>	<input type="checkbox"/> No	<input checked="" type="checkbox"/> Yes

D. Project Title(s) and Description(s) *Enter a descriptive 'Title' and brief 'Description' for the lead training project ^{and/or} program proposed for funding from any Grant which may be awarded pursuant to this application.*

(Project Title)	(Description)
1 Bullex Advanced Vehicle Fire Training Prop & Options	The Advanced Vehicle Fire Training Prop is a propane fueled live-fire training allo prop which allows for comprehensive fire training for the Peninsula region's incumbent and recruit firefighters. The prop meets or exceeds NFPA 1001, 1403 & 1500.
Which statement best describes the above proposed project and/or program? <i>check <input checked="" type="checkbox"/> one</i>	<input checked="" type="checkbox"/> New <input type="checkbox"/> Change to existing <input type="checkbox"/> Continuing
Which statement best describes how many training programs may benefit from the proposal? <i>check <input checked="" type="checkbox"/> one</i>	<input checked="" type="checkbox"/> Multiple Programs <input type="checkbox"/> Single Program
Describe the impact on training if this Grant is not awarded, or check <input checked="" type="checkbox"/> No Significant Impact	
The NNFD and Peninsula Regional Burn Building Partnership currently utilizes donated vehicles for vehicle fire props and training. In order to use these, we must, or have the salvage yard, fully strip the vehicles and ensure that all fluid and other hazardous items are removed. The addition of this propane vehicle fire prop will enhance our training as well as cause a cleaner & safer environment.	
<input type="checkbox"/> ← <i>Check <input checked="" type="checkbox"/> IF a Continuation D Sheet is used to account for more than one (1) project / program.</i>	
IMPORTANT , if box above is checked and no continuation sheets are attached, the application will not be further considered.	

E. Project Goods & Services Requested

In the below table, itemize in priority order – starting with the most needed first, **ALL** items of "Goods" (e.g. equipment, hardware or other durable items) or categories of "Services" which are to be funded in whole or in part from any Grant which may be awarded pursuant to this application.

Enter Project Title from [D] above	Check <input checked="" type="checkbox"/> One	Description	Total Cost	Less any Matching Funds	Grant Amount Requested
1 Bullex Adv Vehicle Fire Training Prop - System Package	<input checked="" type="checkbox"/> Goods <input type="checkbox"/> Services	The Vehicle Fire System Package includes the following: Bullex Car Fire Prop (with 4 burn zones, 10-yr construction warranty, pryable hood, and integrated cooling system), Fire Tray and Pilot Control Box and the Mobile Control Console	(a) \$ 39,895.00	(b) \$ -	(a-b) \$ 39,895.00
2 Bullex Adv Vehicle Fire Training Prop - Integrated Vehicle Smoke Option	<input checked="" type="checkbox"/> Goods <input type="checkbox"/> Services	This option allows for the addition of realistic smoke effects by the use of an industrial grade smoke generator capable of 4,000 cubic ft/min of zero visibility smoke. The generator is built into the prop with protective heat shielding	(a) \$ 4,895.00	(b) \$ -	(a-b) \$ 4,895.00
3 Bullex Adv Vehicle Fire Training Prop - Wireless Control Option	<input checked="" type="checkbox"/> Goods <input type="checkbox"/> Services	The wireless control option is of rugged design that integrates with the car fire prop and the generator option. This allows for instructor safety and is built with a rapid stop button for immediate shutdown if warranted.	(a) \$ 4,195.00	(b) \$ -	(a-b) \$ 4,195.00
4 Bullex Adv Vehicle Fire Training Prop - Installation Set-up and Training	<input type="checkbox"/> Goods <input checked="" type="checkbox"/> Services	Includes shipping, delivery to the site, set-up and testing of all functions, 4 hour train-the-trainer for up to 10 people, 1-year comprehensive warranty, and 10 year construction warranty.	(a) \$ 2,680.00	(b) \$ -	(a-b) \$ 2,680.00
5	<input type="checkbox"/> Goods <input type="checkbox"/> Services		(a) \$ -	(b) \$ -	(a-b) \$ -

← *Check IF a Continuation D Sheet is used to account for **more than one (1) project / program.***
IMPORTANT, if box above is checked and no continuation sheets are attached, **the application will not be further considered.**

E	Enter here the lesser amount of: • Sum of all items (1 thru n) under "Grant Amount Requested" • OR \$50,000 (<i>Grant maximum</i>)	\$ 50,000.00
---	---	---------------------



Administration

MAR 02 2016

Department of Fire Programs

F. Matching/Cost Share

1 Which statement best describes the matching funds contributions?
check one

50% or More Less than 50% None

G. ATL Funding

1 What is the amount of the Applicant's FY-2015 Aid to Localities (ATL) allocation from the Fire Programs Fund?
check one and complete as necessary

\$10,000 or \$20,000 exactly
 Other - Enter amount here \$ 572,543.00

2 Did the Applicant have cash carry forward from FY-2015 into FY-2016 from previous years' Aid to Localities (ATL) allocations?
check one and complete as necessary

Yes No

If "Yes", amount of FY-2015 ATL carry forward: \$365,405.82

Remarks

Make entries or check None **Important** If the sum (1 to n) of individual "Grant Amount, Requested" in E above exceeded \$50,000, an explanation must be entered here as to how the shortfall would otherwise be made up.

The total amount of the Vehicle Fire Prop with the added options exceeds \$50,000, the total price is \$51,665. The Grant application is through the City of Newport News for the Peninsula Regional Burn Building Partnership. Each of the seven represented partner jurisdiction contribute \$1,500 annually for maintaining and purchasing items at the regional partnership facility. The current balance of the BB Maintenance account exceeds \$69,000. The partnership fire chiefs approved the use of funds from this account to make up any shortfall between the grant award and total price of the prop.

*** Please see the attached justification statement for additional details relative to the application for the grant award.
*** The renewal MOA for the Peninsula Regional Burn Building Partnership is in DRAFT and is in circulation to the member jurisdictions prior to the final version's circulation for approval by the individual jurisdictions' governing bodies. ***

EFT (EDI)

Grant awards are paid as an **Electronic Funds Transfer / EDI** to the current account-of-record for the jurisdiction's annual allocation of Aid to Localities (ATL) from the Fire Programs Fund.

Certification:

To be completed by either:

- County Administrator –or- Executive, City Manager, Town Mayor –or- Administrator; Deputy, or...
- Other duly authorized official whereby the application is accompanied by a copy of an 'Ordinance' or other such formal instrument clearly granting that party such authority.

This grant application is entered on behalf of the APPLICANT jurisdiction identified above with the knowledge and belief that all representations herein made are true and correct; with the understanding that all grant terms & conditions in-force as of the date of such application are hereby included by reference; with the further understanding that if an award is granted pursuant to this application that the recipient is bound by those same terms & conditions.

Signature: James M. Bourey Date: 2/25/16
Printed Name: James M. Bourey Title: City Manager

(All applications must be notarized to be considered – incomplete forms shall be returned.)

State of Virginia

City / County of Newport News

On this 25th day of February (month) in 2016 (year), before me, the undersigned a Notary Public for the Commonwealth of Virginia, personally appeared James M. Bourey to me known (or to me proved) to be the identical person named herein and having in my presence executed the above, and acknowledged that he executed same as a voluntary act and deed.

My Commission expires: NOV. 30, 2017 Barbara Lea Warren Ketchum
Date Notary Public



The Newport News Fire Department (NNFD) is a career department that provides fire, EMS, specialty team and emergency management response services to a city that is 23 miles long and three miles wide totaling 69 square miles. Newport News is situated in the Hampton Roads region of Virginia and serves over 180,000 residents as well as those that work within the City and those which travel through Newport News. The NNFD has a professional Training Bureau consisting of an assistant chief, two captains, three lieutenants, one master firefighter and one administrative assistant. The staff is responsible for training the department's incumbent personnel as well as recruits from the NNFD and the other regional jurisdictions through the Tidewater Regional Fire Academy (TRFA). The NNFD's Training Center encompasses a campus which includes a Class A live-fire training building, a Flashover Simulator, a 4-story training tower, a LP gas live fire training prop, a roof ventilation training prop, a confined space training prop, vehicle fire training props, a SCBA maze as well as other portable training props. All of the aforementioned props are part of the Peninsula Regional Burn Building Partnership (Partnership). The Partnership is documented in a Memorandum of Agreement, and aside from the formation of the Partnership, the document addresses the initial financial contribution of each participating jurisdiction as well as the annual contribution of each member.

The NNFD Training Center is the primary location of all recruit TRFAs conducted on the Peninsula. The Partnership allows for a substantial training environment which has developed into a well-equipped facility prepared to deliver all aspects of NFPA 1001 and 1403 required Firefighter I and II. NNFD hosts two TRFAs annually which certifies new firefighters in Firefighter I and II, EVOC, Basic Pumps, Introduction to Technical Rescue Modules I and II, Vehicle I, Communicating with Children, Mayday Firefighter Down, and Mayday Technician. All of the resources utilized for the academies are housed at the Newport News Fire Training

Center. Aside from the above noted training props, the training center includes an extensive ladder compliment, SCBA training props, a portable hose bed, several hydrants, a full hose assortment, drafting tank, hand tools, hydraulic tools, rope and other necessary training articles. The TRFAs are conducted by officers from the above jurisdictions as well as the NNFD training staff and is organized with a director, coordinator (Instructor II minimum), co-coordinator, lead instructor (Instructor II minimum), and TRFA instructors. The academy utilizes the *Jones and Bartlett Fundamentals of Firefighting 3rd Edition* for Firefighter I and II coursework and skill work and culminates with the Virginia Department of Fire Programs (VDFP) State Firefighter I and II testing. The academy also utilizes the VDFP documentation to guarantee adherence to both NFPA 1001 and NFPA 1403.

Incumbent training occurs at the NNFD Training Center as well, and is carried out by both the training staff and the company officers. Training consists of practical scenarios, individual Firefighter I and II skills, live fire exercises, and other techniques and topics. NNFD fire companies are required to complete scenarios at the Training Center on a monthly basis as well as multi-company and multi-jurisdictional training several times a year. The NNFD HAZMAT Team, Technical Rescue Team, Bomb Team, and Marine Incident Response Team also utilize the Training Center for monthly specialty team training. In addition to the NNFD personnel utilizing the Training Center, all surrounding jurisdictions schedule regular incumbent training at this facility. The most common types of training utilized by the regional partners is live fire, use of the training tower and the flashover simulator.

The NNFD/Partnership Regional Training Center currently utilizes donated vehicles to obtain and maintain proficiency in combatting vehicle fires per NFPA 1001. When donated, either the salvage yard that donates the vehicles or the Training Staff must fully strip the vehicles

of any combustible materials, remove all engine compartment components and other hazardous components and drain all fluid. When accomplished, Class A material is used for the live-fire component. Over time, these vehicles become warped and have to be replaced causing the cycle to continue. Furthermore and although Class-A materials are burned, the run-off from the training evolutions must be considered in the realm of environmental impact.

The request for this grant will alleviate these concerns. The vehicle fire prop requested utilizes propane as the live-fire mechanism which is cleaner and significantly reduces the run-off concerns to almost zero. Moreover, unlike the current mechanism for vehicle fire training, the propane vehicle fire prop maximizes safety through the control box and which includes a dead-man button and rapid stop switch. In order to maximize our training capability, we are including the integrated vehicle smoke option to give the students the most realistic experience. We are also including the wireless remote control option into this grant application. This option allows the instructional staff to control all four burn zones with the prop in addition to the vehicle smoke option any future compatible add-on options available through the manufacturer. Lastly, the NNFD/Regional Training Center currently has an LP-Gas training prop which was fully donated by the Virginia Propane Association. This prop includes a burn tank simulator and a 1,000 gallon propane tank. The piping for this prop is compatible with the requested vehicle fire prop which removes the need to purchase a tank for the requested prop.

As noted on the grant application, the total cost of the prop, the requested option and delivery/set-up/training exceeds the maximum award of \$50,000. As stated above, the Peninsula Burn Building Partnership jurisdictions contribute annually to a maintenance fund for the burn building and other regional training assets housed at the NNFD Fire Training Center. Per the

agreement of all represented jurisdictional fire chiefs, any needed funding above the maximum award will come from this account.

It remains clear that the Newport News Fire Training Center and the Peninsula Regional Training Facility are equipped to provide superior instruction in all required aspects of Firefighter I and II as well as advanced firefighter and specialty training. It is also evident that the facilities provide a location where all jurisdictions in the region are able to complete regular training in order to serve their communities and become better prepared. The natural progression of the site, particularly with an LP-Gas prop, is the addition of the requested vehicle fire prop and options. This prop will be used for recruits and incumbents from the Partnership departments as well as volunteer departments in the region. Additionally, the move away from donated vehicles using Class A material provides a safer and more environmentally friendly component to the region's training complex.

NEWPORT NEWS REGIONAL LIVE FIRE TRAINING FACILITY

MEMORANDUM OF AGREEMENT

This MEMORANDUM OF AGREEMENT dated this 1st day of February, 2000, by and among the CITY OF NEWPORT NEWS, CITY OF HAMPTON, COUNTY OF JAMES CITY, CITY OF POQUOSON, CITY OF WILLIAMSBURG, COUNTY OF YORK and U.S. ARMY TRANSPORTATION CENTER; all of the Commonwealth of Virginia and United States of America, and hereinafter collectively referred to as "Partners".

WHEREAS, Partners have agreed in principle to jointly construct and operate a regional live fire training facility, hereinafter referred to as "Facility", with Newport News serving as the host jurisdiction for the facility; and

WHEREAS, Partners have budgeted capital funds necessary to develop and maintain the Facility; and

WHEREAS, the Commonwealth of Virginia has agreed to provide additional capital funds necessary for the construction of the Facility conditioned upon the Partners executing a regional agreement for the operation and maintenance of the Facility.

NOW, THEREFORE, it is hereby agreed by and among the Partners as follows:

1. DEFINITIONS

Additional Partners shall mean entities that are not included in the list of partners as provided in this agreement dated the 1st day of February, 2000, but which are accepted as Partners subsequent to the execution of this Agreement.

Agents means and includes authorized officers, employees and agents of a Partner.

Agreement shall mean this Memorandum of Agreement, as amended from time to time.

Committee shall mean the committee established pursuant to Section 5 of this Agreement.

Facility shall mean the regional Live Fire Training Facility.

Partner shall mean any one of the Partners or Additional Partners.

Partners shall be a collective term meaning the jurisdictions of the City of Newport News, City of Hampton, County of James City, City of Poquoson, City of Williamsburg, County of York, Virginia; and the U.S. Army Transportation Center at Fort Eustis, Virginia; and all Additional Partners, if any.

Regional Live Fire Training Facility and Facility shall mean land, designated roadways leading immediately thereto, utilities, burn building, and any other physical structures and facilities located on property designated for and used by the Partners for the purpose of operating a regional live fire training facility.

2. PURPOSE

The purpose of this agreement is to construct, operate and maintain a facility by and among the Partners hereto that will provide a live fire training facility for the Partner's fire fighting personnel.

3. DURATION

A. The initial term of this agreement shall be 15 years commencing on the date of the organizational meeting. At the expiration of the initial 15 year term, this Agreement may be renewed based on the approval of and for a term determined by a majority of the then active Partners.

B. This agreement is additionally subject to the continued financial support of the Partners and thus subject to continued appropriation by the Partners of funds necessary for the construction and operation of the Facility.

4. THE FACILITY

A. The initial Facility improvements shall include the following: a one story training building with an attached one story commercial space, the overall dimensions of which will be approximately 46' x 26'. The site will be provided with storm water management, and served by water, access roads, required parking and other paved areas necessary for the training facility.

B. The construction, maintenance and operation of, and improvements to the Facility will comply with all state and federal laws, rules and regulations under the direction of the Committee, the City of Newport News, Virginia, and the terms of the grant agreement between the Department of Fire Programs and the City of Newport News, Virginia, for the construction and operation of the Facility. The Newport News Purchasing Department will handle the procurement of all services, materials and supplies for the construction, maintenance and operation, and improvements to the Facility upon written direction of the Committee.

C. The Newport News Finance Department will process all invoices for payment for construction activities, materials and supplies. Newport News will bill each Partner annually during the month of October for operation and maintenance costs, if any, based on each Partner's use of the

Facility during the preceding fiscal year.

D. From time-to-time during the initial or subsequent terms of this Agreement, the Partners may consider additional capital improvements or additions to the Facility. Any decision to build any additional regional structures to the Facility must first be approved unanimously by the then active Partners.

B. The Facility shall be owned solely by the City of Newport News. No other Partner or other entity shall acquire a property interest in the Facility solely by virtue of participating in this Agreement, or using the facility for training or otherwise.

5. THE COMMITTEE

A. The Committee will consist of seven (7) members appointed as follows:

Chair: The Chair shall be a member of the Committee who shall have all rights of membership including the right to vote. The Chair shall rotate each calendar year among the Committee members as determined by the Committee. The Chair shall function as the chair of the Committee but shall have no additional powers or authority not available to the other members of the Committee, except as otherwise approved by a majority of all the Committee members.

Members: The chief, or other operational equivalent, of each Partner's fire department, including their designees, shall serve as that Partner's member on the Committee.

B. The Committee shall adopt and be governed by bylaws. Such bylaws shall include the following components:

1. **Quorum.** A quorum shall consist of four (4) members present and voting, however, in order for the Committee to approve any budgetary action, the quorum shall consist of five (5) members present and voting. Proxy voting shall be authorized except that proxy votes may not be used to satisfy the requirement for a quorum.
2. **Meeting Schedule.** To be held at such time and on such dates as provided in the by-laws, and at such additional times and dates as otherwise determined by the Committee.
3. **Notice of Meetings.** A notice of every meeting shall be faxed to all members of the Committee no less than five working days prior to the meeting date.

4. Organizational Meeting. The Committee shall hold an organizational meeting after all Partners have executed this Agreement. As each partner executes this Agreement, it shall forward the original of the executed Agreement to the Newport News Fire Chief who shall retain the Agreement until such time as all Agreements are received. Upon receipt of all Agreements, the Newport News Fire Chief shall notify every Partner of the time, date and location of the organizational meeting. Upon the presence of every Partner's representative at the organizational meeting, the Newport News Fire Chief shall call the meeting to order for the purpose of electing a Chair from amongst the representatives. Upon election of the Chair, the first order of business shall be to adopt by-laws for the Committee, however the organizational meeting may be continued from time to time until the by-laws are adopted. Upon adoption of the by-laws, the Committee may entertain any other business it desires to be necessary, at the conclusion of which, the organizational meeting shall be adjourned.
5. Action by Committee. - Upon reaching a quorum, all actions required to be taken or approved by the Committee shall be taken or approved by a majority vote of those present and voting, including proxy votes.

6. FACILITY OPERATIONAL CONTROL

A. The use of the Facility shall be under the control, direction and supervision of the Committee with the objective of insuring safe operation of the Facility. Subject to the terms and conditions of this Agreement, the Committee shall establish conditions for use of the Facility as the Committee shall deem necessary in the interest of safety and prudent operational efficiency. This authority may be delegated by the Committee to the City of Newport News.

B. Operational and maintenance costs of the Facility shall be administered by the Committee and borne by the Partners, based on use as provided in section 4(C), which shall provide for such costs in their annual operating budgets, or from funds provided by the Virginia Department of Fire Programs or its successor.

7. SPECIFIC PROVISIONS - NEWPORT NEWS

A. Newport News shall make available a portion of 14.9 acres of land at 17300 Warwick Boulevard, Newport News, Virginia, located between Lee Hall Elementary School and the Allegheny Pepsi site for the Facility. Newport News shall retain ownership of the land and improvements throughout the term of this agreement.

B. Newport News shall make all applications on the Committee's behalf related to building permits, zoning and any other permits required for the Facility; and Newport News will, as expeditiously as possible, take all actions necessary to obtain all required zoning, special use and building permits.

C. Newport News shall be the responsible jurisdiction for bidding and procuring an architect and builder of the Facility, as well as all procurement related to the operation and maintenance of the Facility.

D. Newport News shall prepare a draft site plan that provides general dimensions of the Facility, and includes proposed building locations with draft architectural drawings. The final plans for the burn building shall be approved by the Committee.

E. Newport News shall coordinate and insure that utilities, trash removal and routine Facility maintenance is provided for so long as it is a partner to this Agreement.

8. MUTUAL OBLIGATIONS

A. The Partners agree to provide contributions of assets or funds as identified in Appendix A for the construction of the Facility. Additionally, the Partners agree to annually provide funds for the operation, maintenance and non-capital improvements to the Facility, if any are needed, based on their proportional use of the Facility during the preceding fiscal year.

B. The provisions of this agreement are for the sole benefit of the Partners, and no other person or entity shall be entitled to enforcement of any part or parts of this Agreement.

C. Annual operating costs and maintenance of the Facility:

(1) The Committee shall adopt an annual operating and maintenance budget for the Facility and shall submit such budget to the Newport News Fire Chief by December 15 of each year.

(2) The Newport News Fire Chief or his designee will prepare an itemized invoice and forward to the other Partners an annual billing for their pro-rata actual cost of operating and maintaining the Facility during the previous fiscal year as provided in section 4(C). The Partners agree that they will, within 60 days of the invoice, review, approve and forward payment to the Newport News Fire Chief for their pro-rata share of the costs.

9. LIABILITIES

A. In so far as permitted by law, each Partner agrees that, as between the Partners, it shall be responsible for its own agents' acts and omissions within the scope of their duties which cause injury to persons or property directly resulting from their use of the Facility. Nothing herein shall be deemed as a waiver of sovereign immunity or any other defense available to a Partner.

B. Each Partner shall have responsibility for and control over its Agents.

C. This Agreement shall not be construed to impair or affect any sovereign or governmental or official immunities that may otherwise be available to a Partner or its Agents. Any legal liability which may be imposed upon a Partner by a court of competent jurisdiction or by duly authorized settlement of any legal claim against a Partner, shall be the responsibility of and retained by that Partner for the conduct of its own affairs. In the event of a third party liability determination not covered by this paragraph or in the event the Committee is sued or ultimately held liable, the Partners shall share in the proportions set forth in the "POP%" column in appendix A in all costs of defense and in any monetary judgment or settlement of such claim, unless otherwise mutually agreed to by all Partners.

D. Each Partner shall be responsible for worker's compensation liability for their respective Agents who may suffer compensable injuries arising out of their use of or authorized presence at the Facility.

10. TERMINATION

A. Any Partner may terminate its participation in this Agreement by providing 90 days written notice, certified mail return receipt requested, to the chief executive officers of all the other Partners. The City of Newport News shall retain ownership of the Facility and shall have and receive ownership of all personal property and equipment and other assets of the terminating Partner not removed by such Partner prior to termination. The terminating Partner shall execute any quit claim deed, bills of sale or conveyances reasonably requested by the City of Newport News to evidence Newport News's ownership of all such assets.

B. A terminating Partner shall forfeit all interests, property or otherwise, if any, in the facility and its operations, however the terminating Partner shall continue to be liable for any obligation incurred during such time as the terminating Partner was a Partner, specifically including the operating and maintenance costs calculated on the Partner's use of the Facility in the prior fiscal year, as well as any costs provided for in Section 9, Liabilities, of this agreement.

11. **EFFECTIVE DATE**

This agreement shall be effective at such time as all parties hereto have executed same as an original and copies of the original have been provided to all parties hereto.

END OF SUBSTANTIVE PROVISIONS - APPENDIX AND SIGNATURE PAGES FOLLOW

kdk5639

Financial Shares by Partner Locality Based on Population

PARTNERS:	SHARE %	*** BASE SHARE	SHORTFALL	TOTAL SHARE
Newport News **	39.8	\$149,266	\$0.00	\$149,266
Hampton *	30.7	91,750	N/A	91,750
York County	12.6	47,262	3,600	50,862
James City County	9.7	36,383	2,770	39,153
Williamsburg	2.6	9,778	752	10,530
Poquoson	2.5	9,383	716	10,099
U.S. Army Transportation Center	1.8	6,798	542	7,340
TOTAL PARTNERS' CONTRIBUTION				\$359,000
STATE DEPARTMENT OF FIRE PROGRAMS				225,000
TOTAL FUNDING				\$684,000

* Hampton's fixed share agreed upon because Hampton also uses and contributes to the Langley Air Force Base burn facility.

** Newport News excluded from contributing to shortfall; in lieu thereof, Newport News will contribute all administrative expenses.

*** Base share includes payment of required stormwater management fees.

APPENDIX "A"

RESOLUTION NO. 9671-00

A RESOLUTION AUTHORIZING AND DIRECTING THE CITY MANAGER TO EXECUTE AND THE CITY CLERK TO ATTEST, ON BEHALF OF THE CITY OF NEWPORT NEWS, VIRGINIA, THAT CERTAIN MEMORANDUM OF AGREEMENT BY AND AMONG THE CITY OF NEWPORT NEWS, THE CITY OF HAMPTON, THE COUNTY OF JAMES CITY, THE CITY OF POQUOSON, THE CITY OF WILLIAMSBURG, THE COUNTY OF YORK AND THE U. S. ARMY TRANSPORTATION CENTER DATED THE 1ST DAY OF FEBRUARY, 2000, FOR THE NEWPORT NEWS REGIONAL LIVE FIRE TRAINING FACILITY.

NOW, THEREFORE, BE IT RESOLVED by the Council of the City of Newport News:

1. That it hereby authorizes and directs the City Manager to execute and the City Clerk to attest, on behalf of the City of Newport News, Virginia, that certain Memorandum of Agreement by and between the City of Newport News, the City of Hampton, the County of James City, the City of Poquoson, the City of Williamsburg, the County of York and the U. S. Army Transportation Center dated the 1st day of February, 2000.

2. That a copy of the said Memorandum of Agreement is attached hereto and made a part hereof.

PASSED BY THE COUNCIL OF THE CITY OF NEWPORT NEWS MAY 9, 2000

**Bernice I. Berry, MMC
City Clerk**

**Joe S. Frank
Mayor**

A true copy, teste:

Bernice I. Berry
City Clerk

WITNESSETH the following signatures and seals on behalf of the City of Newport News,
Virginia, in that behalf having first been duly authorized:

CITY OF NEWPORT NEWS, VIRGINIA

Edgar E. Maroney
City Manager

ATTEST:

Bernice L. Berry
Deputy City Clerk

Prepared/Reviewed:

Leonard E. Ringler
Deputy City Attorney

Approved as to Form:



Stuart E. Katz
City Attorney

WITNESSETH the following signatures and seals on behalf of the City of Hampton,
Virginia, in that behalf having first been duly authorized:

CITY OF HAMPTON, VIRGINIA



George E. Wallace
City Manager



Robert Green
Fire Chief

ATTEST:

City Clerk

CITY OF HAMPTON
OFFICE OF THE CITY ATTORNEY

This contract has been reviewed
and is approved as to form.

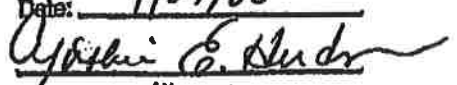
Date: 4/24/00

Attorney

○ WITNESSETH the following signatures and seals on behalf of the City of Williamsburg,
Virginia, in that behalf having first been duly authorized:

CITY OF WILLIAMSBURG, VIRGINIA

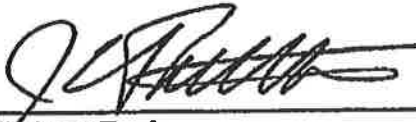

Jackson Tuttle
City Manager



T. K. Weiler
Fire Chief

() ATTEST:



Mary Beth Plucinski
City Clerk (Acting)

WITNESSETH the following signatures and seals on behalf of the City of Poquoson,
Virginia, in that behalf having first been duly authorized:

CITY OF POQUOSON, VIRGINIA



Charles W. Burgess, Jr.
City Manager



Carl E. Ward
Fire Chief

ATTEST:

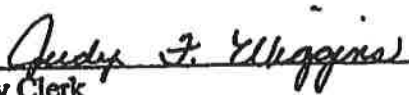

Judy F. Higgins
City Clerk

WITNESSETH the following signatures and seals on behalf of the County of James City,
Virginia, in that behalf having first been duly authorized:

COUNTY OF JAMES CITY, VIRGINIA



Sanford B. Wanner
County Administrator



Richard Miller
Fire Chief

ATTEST:



County Clerk

WITNESSETH the following signatures and seals on behalf of the County of York, Virginia,

in that behalf having first been duly authorized:

COUNTY OF YORK, VIRGINIA



Daniel M. Stuck
County Administrator



Stephen P. Kopczynski
Fire Chief

ATTEST:



~~County Clerk~~ Administrative Assistant

APPROVED AS TO FORM:



COUNTY ATTORNEY

WITNESSETH the following signatures and seals on behalf of the U.S. Army Transportation Center, Fort Eustis Virginia, in that behalf having first been duly authorized:

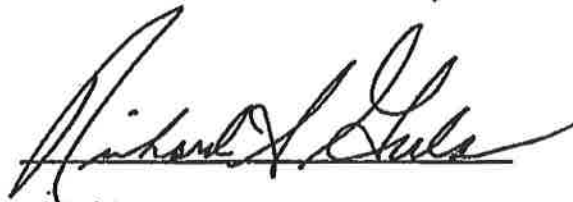

Richard S. Gula
Colonel, TC
Garrison Commander



Stephen P. Jellie
Chief, Fire & Emergency Services
USATC & Fort Eustis

ATTEST:



USATC, SJA

**RENEWAL OF NEWPORT NEWS REGIONAL LIVE FIRE TRAINING FACILITY
MEMORANDUM OF AGREEMENT**

THIS RENEWAL, dated February 1, 2015, to that certain MEMORANDUM OF AGREEMENT dated February 1, 2000 (the "Agreement"), by and among the CITY OF NEWPORT NEWS, CITY OF HAMPTON, COUNTY OF JAMES CITY, CITY OF POQUOSON, CITY OF WILLIAMSBURG, COUNTY OF YORK, AND U.S. ARMY TRANSPORTATION CENTER, hereinafter collectively referred to as the "Partners."

WHEREAS, pursuant to the Agreement, the Partners agreed to and have constructed and operated a regional live fire training facility; and

WHEREAS, the Agreement was for a fifteen (15) year term, and provides for renewal based on the approval of and for a term determined by a majority of the active Partners; and

WHEREAS, the Partners desire to extend the term of the said Agreement for an additional fifteen (15) year term.

NOW, THEREFORE, it is understood and agreed by the parties hereto that the Agreement shall be renewed as follows:

1. The term of the Agreement between the Partners dated February 1, 2000, is hereby extended for an additional fifteen (15) year term, ending on January 31, 2030.
2. All other provisions of the Agreement that are not inconsistent herewith remain in full force and effect.

[Signature Pages Follow]

Newport News Fire Department

ADVANCED VEHICLE FIRE TRAINING PROP

Budgetary Proposal

February 16, 2016



Quote Number: 85724
Date: 2.16.2016
Sales Person: Kathy Plant
Valid Until: 5.16.2016
Terms: See General Terms and Conditions

Contact: Dennis West
Address: Newport News, VA
Email: drwest@nnva.gov



Greetings

BullEx is proud to provide the following offer. Our advanced Vehicle Fire Training System is designed to provide realistic live fire training suited to your specific needs. BullEx offers smashable headlights, pry-able hood and an integrated cooling system as standard features of our vehicle prop package. Note that all BullEx props are covered by a ten year construction warranty. In addition, the pilot box, control console and all associated components are covered by a one year comprehensive warranty. The specifications and the corresponding BullEx offer are summarized below.

BullEx Vehicle Fire Training System Package

Price: \$39,895

The BullEx Vehicle Fire Training System includes:

BullEx Car Fire Prop

- **10-year construction warranty**
- **1/4" and 1/8" all steel construction with protective heat resistant paint**
- **1/3" C Channel galvanized steel frame. Thicker gauge steel at high heat areas allows for much longer life of car.**
- **Industrial gauge integrated steel casters for moving car prop**
- **Car prop dimensions: 12'6"l x 5' 6"w x 4'6"h**
- **4 burn zones** - Create passenger compartment, engine, wheel-well and trunk fires at the push of a button
- **Live fire training prop used in conjunction with Hose Line Fire Training System**
- **Hinged hood, trunk, and passenger doors**
- **Driver and passenger seat backs, steering wheel, hood prop bar**
- **Pry-able and Roll-able Hood** - Conduct forcible hood entry drills with the Pry-able and Roll-able Hood feature. The special design with replaceable hood plates of varying difficulty allows for challenging yet repeatable hood-rolling drills without damaging the prop.
- **Integrated Cooling System** - Cooling piping is built into the vehicle itself and connects to a standard garden hose, allowing for long duration fire simulations while minimizing steel fatigue and wear. Ideal



for use when practicing positioning of apparatus, angle of attack, and stretching the proper hose lines, etc. while the vehicle remains fully involved.

- **Smashable Headlights** - Conduct engine compartment extinguishing drills with the Smashable Headlights feature. Specially designed headlight holes in the grill allow for drills of varying difficulty with different types of metal headlight plates.
- All steel construction



Fire Tray and Pilot Control Box

- Removable tray can be positioned independently to simulate a fuel spill or can be used in conjunction with several other BullEx training props
- Engineered for use with hand lines, CO2, and water extinguishers
- Liquid propane fueled industrial grade fire fighter training unit
- Stainless steel 4' x 6' fire tray
- **CSA Listed and Approved stainless steel** continuous burn forced air pilot control box with four (4) burn zones for realistic fire simulation
- Removable pilot box can also be used with other BullEx props or fire trays

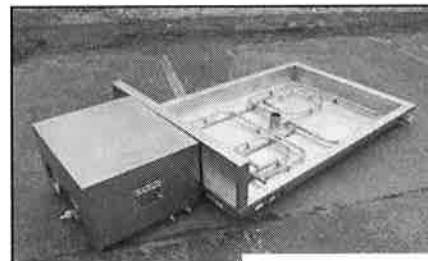
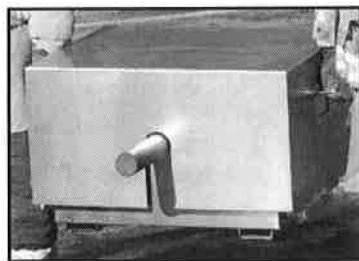

Mobile Control Console

- **UL Approved Control Console** interfaces between props and upstream propane and power supply. Houses core propane and power components, control components, optional wireless and sound effect components (if selected), and **built in E-stop button**.
- Includes 50 foot propane hose with **self-sealing quick disconnect fittings**, specifically designed to prevent gas leaks up to 250psi in high-pressure propane delivery situations. Hose and fittings



constructed to withstand environment elements and heat from normal operation.

- **NEMA 4X** rated to resist corrosion
- Wired remote (unless upgraded to wireless) to independently start and stop multiple burn zones, with deadman button
- Includes power cable to connect to customers power supply

Options:

The following options are also available.

Integrated Vehicle Smoke Option

- Industrial grade smoke generator allows you to add realistic smoke effects during your training session
- 4,000 cubic ft/minute to zero visibility smoke output
- Integrated design produces smoke around the vehicle. Smoke generator is built into the vehicle training prop, with protective heat shielding for optimal long term performance.
- Start and stop the smoke generator using a wireless remote control
- Dual heaters
- 110V 15amp
- Smoke generator can be removed for training in additional locations
- Includes 20L container of BullEx smoke liquid
- Smart controls include:
 - Adjustable smoke output and density settings
 - Continuous run and adjustable intermittent run features
 - Digital smoke liquid reservoir display (shows amount of smoke liquid remaining)

Price: \$4,895



Wireless Control Option

Rugged, industrial grade hand-held wireless remote control. Controls fire simulation systems including four fire zones and add-on fires, and optional features such as smoke effects, and sound effects. Stop button for rapid shutdown. Option will allow operation of one prop at a time.

Price: \$4,195



Installation, Set-up and Training**Price: \$ 2,680****Installation and calibration. Includes:**

- Delivery to site
- Set-up and test operation of all props
- 4 hour train the trainer session for up to 10 people
- User manual
- Toll-Free technical support
- One year comprehensive warranty on materials and parts
- Ten year construction warranty on the steel vehicle prop
- Site work not included. It is the responsibility of the customer to provide propane and electricity to the console.

Our Approach

Realism

BullEx Training Systems are designed to simulate every aspect of a fire or emergency response situation. The fire training systems, structures, and their interior props are constructed accurately to scale, and the fires are built into objects and appliances that would be found in real life. BullEx focuses on building the most realistic fire training scenarios possible allowing trainees to experience the full impact of an emergency situation. Every critical environmental condition that a first responder may face during an emergency can be simulated, including darkness, smoke, sound, flames and heat – depending on the scenario desired. As a result, trainees come to fully experience the challenging physical and psychological effects both on themselves and on others participating in the exercise. Wherever possible, technical instruments and services such as gas and electrical supplies, ventilation systems, and pilot burners are “hidden” from view using special design elements and technologies.

Integrated focus on safety and performance

BullEx training systems are designed, built and installed to ensure that all safety controls are integrated directly into the operational device. Our technicians calibrate the safety settings for each module to maximize safety and ensure all training situations are of a consistent and high quality. BullEx systems are CSA and UL/ULC approved. BullEx’s in-house technical support team is completely familiar with all the details of your system and is on-call to provide the maintenance and service your training requires.

Effective training

Most importantly, the training system you acquire needs to be designed to effectively teach the lessons important for your actual risk and response situation. The training simulator must be a tool that addresses your training needs and serves as a way to support the educational program of your instructors. BullEx is focused on designing systems that help you teach the critical fire and safety skills needed to address your highest risk elements.

Experience

BullEx is a market leader in the field of fire and safety training equipment. Headquartered in New York, with offices in nine countries worldwide, BullEx serves a global customer base with its best-of-class training technologies. Used by thousands of organizations to train millions of fire and safety professionals, BullEx fire training systems have become the industry standard.

Industry Recognition

Our BullEx products have received numerous industry recognitions and awards, including (among others):

- Manufacturing Leadership Awards – New Product Leadership - 2015
- Prestigious Build Award for Excellence in Design and Construction – 2014
- Industry Awards from 2010-2013
- Occupational Safety and Health Magazine – New Product of the Year – 2009
- Australia Fire Awareness Award – 2008
- National Registry of Environmental Professional – Environmental Training Award 2007

We offer a total solutions product line for firefighter training, fire brigade training, fire prevention public education and corporate safety training.

BullEx clients include every branch of the US armed forces, the US Department of Homeland Security, NASA, and thousands of other fire departments, government offices, and corporate clients.



Contact

Thank you for considering BullEx as a trusted source for your fire training. We believe we are uniquely positioned to provide you with competitively priced, high-quality fire training props. Every effort has been made to provide you with a proposal that you will find compelling, complete, and competitive. Choosing a vendor to supply your fire training props is a decision that requires careful evaluation of experience, knowledge, safety, technology and costs. BullEx stands apart from our competition in all of these areas. We ask you to consider the following points as you assess vendor responses:

- The BullEx vehicle prop comes complete with ½” C-Channel galvanized steel frame, ¼” steel in roof, dashboard, and hood of vehicle, and ⅛” throughout remainder of prop.
- Four burn zones for realistic fire simulation. Thicker gauge steel at high heat areas allows for much longer life of car.
- Integrated liquid cooling system, smashable headlights and pry-able hood features are all standard offerings of our vehicle prop.
- We offer a 10-year construction warranty on all our props.
- One-stop shop – We manufacture ALL components that are used in our training tools.
- Our wireless remote option offers a 360° view of training at all times, as opposed to being tethered to a control console.
- Plug and Play capability - Numerous other props are available for purchase that use the same mobile console and pilot box.
- Burn Tray – The 4’ x 6’ stainless steel burn tray allows for multiple burn zones and can be connected to the pilot module to expand training capabilities. The burn tray can serve as its own fuel spill simulation prop.

Please do not hesitate to contact us should you require any more information or have any questions about the proposal provided or our company.

Kathy Plant
Territory Sales Manager

20 Corporate Circle
Albany, NY 12203
Tel: 518.689.2023
Fax: 518.689.2034
www.bullex.com





Item #1: Live Fire Vehicle Training System

The Bidder shall furnish a Vehicle Fire Training Prop.

- A heavy-duty training tool with intense flames, real heat and smart controls.
- Ignite the propane-based flames and have full command of each evolution with the instructor's controller.
- Create passenger compartment, engine, and wheel-well fires at the push of a button.

Includes:

Car Fire Scenario

- Live fire training prop used in conjunction with Hose Line Fire Training System.
- Integrated front tire fire simulator, with multiple burn zones from Hose Line Fire Training System.
- Hinged hood, trunk, and passenger doors.
- Driver and passenger seat backs, steering wheel, hood prop bar.
- Industrial gauge integrated steel casters for moving car prop.
- Hoseline Training System to simulate live fire scenarios; includes:
 - Stainless Steel 4' x 6' fire tray; removable tray can be positioned independently to simulate a fuel spill, or can be used in conjunction with several other training props.
 - CSA Listed and Approved stainless steel continuous burn forced air pilot control box with four (4) burn zones for realistic fire simulation.
 - Removable pilot box can also be used with other props or fire trays.
 - Engineered for use with hand lines, CO2, and water extinguishers.
 - UL Approved Control Console interfaces between props and upstream propane and power supply. Houses core propane and power components, control components, optional wireless and sound effect components (if selected), and built in E-stop button.
 - Wired remote (unless upgraded to wireless) to independently start and stop multiple burn zones, with deadman button.
 - Propane hose with quick connect fittings. Hose and fittings constructed to withstand environment elements and heat from normal operation.
 - Power cable to connect to customer's power supply.

****Vendor will provide current Nationally Recognized Testing Laboratories (NRTL) documents for Pilot Box and Control Console; certifications must be secured prior to purchase, field certifications prior to delivery will not be acceptable****

**** Vendor must include a 10-year construction warranty on the prop itself and a one year comprehensive warranty on parts and materials.***



Vehicle Training System Specifications

- Car Prop dimensions: 12'6" x 5' 6" w x 4'6" h.
- 1/4" and 1/8" all steel construction with protective heat resistant paint. This thick steel construction throughout the entire vehicle allows for unlimited burn time and allows for a 10 year construction warranty.
 - 3 Gauge (1/4") steel on roof.
 - 11 Gauge (1/8") steel on hood.
 - 11 Gauge (1/8") steel on trunk.
 - 11 Gauge (1/8") steel on right fender.
 - 11 Gauge (1/8") steel on left fender.
 - 11 Gauge (1/8") steel on driver door.
 - 11 Gauge (1/8") steel on passenger door.
 - 11 Gauge (1/8") steel on driver seat.
 - 11 Gauge (1/8") steel on passenger seat.
 - 11 Gauge (1/8") steel on steering wheel.
 - 11 Gauge (1/8") steel on dashboard and other ancillary areas.
- 1/3"+ (.354") C Channel galvanized steel frame.

Vendor will provide steel sample of construction material

Additional Vehicle Prop Options:

Pry-able Hood Option

Conduct forcible hood entry drills with the Pry-able and Roll-able Hood. Special design with sacrificial hood plates of varying difficulty allows for challenging yet repeatable hood-rolling drills without damaging the prop. All steel construction.

Smashable Headlights Option

Conduct engine compartment extinguishing drills with the Smashable Headlights. Specially designed headlight holes in the grill allow for drills of varying difficulty with different types of metal headlight plates. All steel construction.

Wireless Control Option

Rugged, industrial grade hand-held wireless remote control. Controls fire simulation systems including four fire zones and add-on fires, and optional features such as smoke effects, and sound effects. Stop button for rapid shutdown.

Integrated Vehicle Smoke Option

- Industrial grade smoke generator allows you to add realistic smoke effects during your training session
- 4,000 cubic ft/minute to zero visibility smoke output



- Integrated design produces smoke around the vehicle. Smoke generator is built into the vehicle training prop, with protective heat shielding for optimal long term performance.
- Start and stop the smoke generator using a wireless remote control
- Dual heaters
- 110V 15amp
- Smoke generator can be removed for training in additional locations
- Includes 20L container of smoke liquid
- Smart controls include:
 - Adjustable smoke output and density settings
 - Continuous run and adjustable intermittent run features
 - Digital smoke liquid reservoir display (shows amount of smoke liquid remaining)
 - Includes 20L container of smoke liquid



General Instructions & Notices

- Applicants are directed to "**Regional Fire Services Training Facilities Grant Program Policy**" as amended for the current funding year which is incorporated by reference to all applications and any subsequent awards. (Such practices document is inclusive of all *terms & conditions*.)
- The filing of an application does not bind the Board to award nor the Department to pay any such grant.
- Incomplete applications and those received after the deadline will not be considered.
(Deadline) → **March 1, 2016** postmarked
- Completed applications executed by the competent authority will only be accepted directly from jurisdictions not fire departments.
- Timeliness of filing and subsequent receipt by the Agency are solely the applicant's responsibility – all applications must be completed in ink and sent directly to: **VDFP Grants and Local Aid Manager,**
Address → **1005 Technology Park Drive, Glen Allen VA 23059-4500**
- All decisions regarding grant awards made by the Board are final; applicants may appeal decisions in writing to the address provided above within 15 business days of the posting of awards.

A. Applicant Information

1. Title of Lead Jurisdiction Making Application (Check <input checked="" type="checkbox"/> only one, then make entry)	<input checked="" type="checkbox"/>	County of	
		City of	Bristol
		Incorporated Town of	
2. Employer Identification Number (EIN)			
3. Principal Point of Contact	(Include salutation, name & title.) Sgt. Tracy S. Hobbs		
4. Mailing Address (Include zip code) Identify COUNTY if appropriate	211 Lee Street Bristol, Va. 24201		
5. Telephone Number	(276)	645-7305	
6. FAX Number	(276)	645-7302	
7. Internet e-mail address	tracy.hobbs@bristolva.org		

B. Additional Parties

	Identify ALL jurisdictions (Not Fire Departments) participating in the proposed project. Attach additional sheets as may be required.		
1. Formal Agreement Among Parties	<p>In accordance with Program Policy, multi-jurisdictional regional training partnerships must be documented (e.g. MOA, MOU, etc.) as required supporting documentation to the Application for consideration of Program funding.</p> <p>A copy of the Agreement has been attached to this application. <input type="checkbox"/> Yes <input type="checkbox"/> No</p> <p><i>If a copy of the Agreement has not been attached as required supporting documentation, this Application will be considered incomplete and funding will not be approved.</i></p>		

Department of Fire Programs

MAR 01 2016

Administration



C. Previous Applications/Awards

1.	Has the Applicant previously applied for a RFSTF Grant from the Board? - check <input checked="" type="checkbox"/> one	<input checked="" type="checkbox"/> No	<input type="checkbox"/> Yes
2.	Has the Applicant previously received a RFSTF Grant from the Board? - check <input checked="" type="checkbox"/> one	<input checked="" type="checkbox"/> No	<input type="checkbox"/> Yes

D. Project Title(s) and Description(s) Enter a descriptive 'Title' and brief Description for the lead training project and/or program proposed for funding from any Grant which may be awarded pursuant to this application.

1	(Project Title) Car Fire Trainer	(Description) A car prop used to train personnel in fire suppression strategies for vehicle fires. The prop is versatile, giving firefighters the ability to learn techniques responding to engine fires, front & rear passenger areas, fuel spill fires.
Which statement best describes the above proposed project and/or program? check <input checked="" type="checkbox"/> one		<input checked="" type="checkbox"/> New <input type="checkbox"/> Change to existing <input type="checkbox"/> Continuing
Which statement best describes how many training programs may benefit from the proposal? check <input checked="" type="checkbox"/> one		<input checked="" type="checkbox"/> Multiple Programs <input type="checkbox"/> Single Program
Describe the impact on training if this Grant is not awarded, or check <input checked="" type="checkbox"/> No Significant Impact		
Car fires pose inherent dangers, without the proper training it can put firefighters safety & health at risk. By having proper training & prop, it will significantly decrease the risk to firefighters. This equipment will not only better BVFD fire response, but the surrounding jurisdictions as well, as they have access & invited to train. This is a regional training center & no prop is currently in the vicinity.		
<input checked="" type="checkbox"/> ← Check <input checked="" type="checkbox"/> IF a Continuation D Sheet is used to account for more than one (1) project / program.		
IMPORTANT , if box above is checked and no continuation sheets are attached, the application will not be further considered.		

E. Project Goods & Services Requested In the below table, itemize in priority order – starting with the most needed first, ALL items of "Goods" (e.g. equipment, hardware or other durable items) or categories of "Services" which are to be funded in whole or in part from any Grant which may be awarded pursuant to this application.

Enter Project Title from [D] above	Check <input checked="" type="checkbox"/> One	Description	Total Cost	Less any Matching Funds	Grant Amount Requested
1	<input checked="" type="checkbox"/> Goods <input type="checkbox"/> Services	Car mock-up: a mobile versatile car prop that allows for several different scenarios for fire attack.	(a)	(b)	(a-b)
			\$ 27,500.00	\$ -	\$ 27,500.00
2	<input checked="" type="checkbox"/> Goods <input type="checkbox"/> Services	Control & Pilot box: the pilot burner, cables power cord, hoses, regulators and hose guards needed to run the car prop.	(a)	(b)	(a-b)
			\$ 12,950.00	\$ -	\$ 12,950.00
3	<input checked="" type="checkbox"/> Goods <input type="checkbox"/> Services	Burn Pan: a stainless steel 4' x 6' pan. Used to produce a high fire output 60,000 btu/hr.	(a)	(b)	(a-b)
			\$ 5,250.00	\$ -	\$ 5,250.00
4	<input type="checkbox"/> Goods <input type="checkbox"/> Services		(a)	(b)	(a-b)
			\$ -	\$ -	\$ -
5	<input type="checkbox"/> Goods <input type="checkbox"/> Services		(a)	(b)	(a-b)
			\$ -	\$ -	\$ -

← Check IF a Continuation D Sheet is used to account for more than one (1) project / program. **IMPORTANT**, if box above is checked and no continuation sheets are attached, the application will not be further considered.

E	Enter here the lesser amount of: • Sum of all items (1 thru n) under "Grant Amount Requested" • OR \$50,000 (Grant maximum)	\$ 46,100.00
---	---	---------------------

Department of Fire Programs

MAR 01 2016

Administration

Continuation Sheet D - Side 1

D		Enter a descriptive 'Title' and brief Description for the lead training project ^{and} / or program proposed for funding from any Grant which may be awarded pursuant to this application.	
	(Title)	(Description)	
2	Burn Pan Trainer	A stainless steel pan. The pan allows for a 4' x 6' burn area that produces a 60,000.000 btu/hr - high fire output.	
Which statement best describes the above proposed project and/or program? check <input checked="" type="checkbox"/> one		<input checked="" type="checkbox"/> New	<input type="checkbox"/> Change to existing <input type="checkbox"/> Continuing
Which statement best describes how many training programs may benefit from the proposal? check <input checked="" type="checkbox"/> one		<input checked="" type="checkbox"/> Multiple Programs	<input type="checkbox"/> Single Program
Describe the impact on training if this Grant is not awarded, or check <input checked="" type="checkbox"/>		<input type="checkbox"/> No Significant Impact	
This burn pan prop will allow BVFD and the regional training center the start to improving the training opportunities to the area. The pan is the base to other props in the future. All firefighters and classes will improve for the area. Surrounding jurisdictions all have open invites to BVFD training. With this being a regional training center all props are available to the neighboring jurisdictions.			

D		Enter a descriptive 'Title' and brief Description for the lead training project ^{and} / or program proposed for funding from any Grant which may be awarded pursuant to this application.	
	(Title)	(Description)	
3			
Which statement best describes the above proposed project and/or program? check <input checked="" type="checkbox"/> one		<input type="checkbox"/> New	<input type="checkbox"/> Change to existing <input type="checkbox"/> Continuing
Which statement best describes how many training programs may benefit from the proposal? check <input checked="" type="checkbox"/> one		<input type="checkbox"/> Multiple Programs	<input type="checkbox"/> Single Program
Describe the impact on training if this Grant is not awarded, or check <input checked="" type="checkbox"/>		<input type="checkbox"/> No Significant Impact	

D		Enter a descriptive 'Title' and brief Description for the lead training project ^{and} / or program proposed for funding from any Grant which may be awarded pursuant to this application.	
	(Title)	(Description)	
4			
Which statement best describes the above proposed project and/or program? check <input checked="" type="checkbox"/> one		<input type="checkbox"/> New	<input type="checkbox"/> Change to existing <input type="checkbox"/> Continuing
Which statement best describes how many training programs may benefit from the proposal? check <input checked="" type="checkbox"/> one		<input type="checkbox"/> Multiple Programs	<input type="checkbox"/> Single Program
Describe the impact on training if this Grant is not awarded, or check <input checked="" type="checkbox"/>		<input type="checkbox"/> No Significant Impact	

Be sure that if this continuation work sheet is used, your application is both properly marked and this sheet is included with your application filing.

Department of Fire Programs

MAR 01 2016
Administration



F. Matching/Cost Share

1	Which statement best describes the matching funds contributions? <i>check <input checked="" type="checkbox"/> one</i>	<input type="checkbox"/> 50% or More	<input type="checkbox"/> Less than 50%	<input checked="" type="checkbox"/> None
---	--	--------------------------------------	--	--

G. ATL Funding

1	What is the amount of the Applicant's FY-2015 Aid to Localities (ATL) allocation from the Fire Programs Fund? <i>check <input checked="" type="checkbox"/> one and complete as necessary</i>	<input type="checkbox"/> \$10,000 or \$20,000 exactly	<input checked="" type="checkbox"/> Other - Enter amount here	\$ 51,000.00
2	Did the Applicant have cash carry forward from FY-2015 into FY-2016 from previous years' Aid to Localities (ATL) allocations? <i>check <input checked="" type="checkbox"/> one and complete as necessary</i>	<input type="checkbox"/> Yes	<input checked="" type="checkbox"/> No	If "Yes", amount of FY-2015 ATL carry forward: _____

Remarks	Make entries or check <input checked="" type="checkbox"/>	<input type="checkbox"/> None	Important If the sum (1 to n) of individual "Grant Amount Requested" in E above exceeded \$50,000, an explanation must be entered here as to how the shortfall would otherwise be made up.

EFT (EDI)

Grant awards are paid as an Electronic Funds Transfer / EDI to the current account-of-record for the jurisdiction's annual allocation of Aid to Localities (ATL) from the Fire Programs Fund.

Certification:

- To be completed by either:
- County Administrator –or- Executive, City Manager, Town Mayor –or- Administrator; Deputy, or...
 - Other duly authorized official whereby the application is accompanied by a copy of an 'Ordinance' or other such formal Instrument clearly granting that party such authority.

This grant application is entered on behalf of the APPLICANT jurisdiction identified above with the knowledge and belief that all representations herein made are true and correct; with the understanding that all grant terms & conditions in-force as of the date of such application are hereby included by reference; with the further understanding that if an award is granted pursuant to this application that the recipient is bound by those same terms & conditions.

<u>Tracy S Hobbs</u> Signature		<u>2-25-16</u> Date
<u>TRACY S. Hobbs</u> Printed Name		<u>Sgt</u> Title

(All applications must be notarized to be considered – incomplete forms shall be returned.)

State of Virginia }
City County of Bristol }

On this 25 day of Feb. (month) in 2016 (year), before me, the undersigned a Notary Public for the Commonwealth of Virginia, personally appeared Tracy Hobbs to me known (or to me proved) to be the identical person named herein and having in my presence executed the above, and acknowledged that he executed same as his voluntary act and deed.

My Commission expires: 2-25-16 Date Sylvia Dobson Notary Public

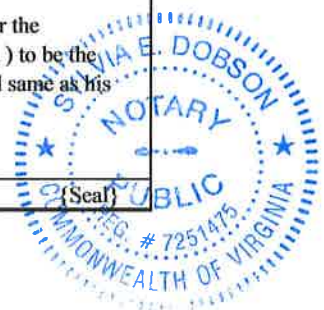

Department of Fire Programs

MAR 01 2016

Administration

Kidde Fire Trainers, LLC
17 Philips Parkway
Montvale, NJ 07645-1810 USA
Tel +1 201.300.8100
Fax +1 201.300.8101
www.kiddefit.com



Q10294-JE-15Jan2016

Bristol Fire Department
211 Lee Street
Bristol, VA 24201

Attention: Sgt. Tracy Hobbs

Subject: Budgetary Proposal for a Kidde FIRETRAINER® Systems

Dear Sgt. Hobbs,

Kidde Fire Trainers, LLC is pleased to provide this budgetary price proposal for your consideration. We have included various options, the pilot box, hoses, and controls are required for all items. All of the controls, props, and systems are NRTL, 3rd party certified, by ETL.

We welcome the opportunity to discuss this proposal and can revise the options to your needs. The pricing is structured for a standalone control system, typically with the pan fire, then to add options for additional props. The car prop does not require the use of a pan.

Please do not hesitate to contact me at (410) 256-3126 with any questions. We look forward to fulfilling your fire training needs.

Sincerely,

James R. Eicholtz

James R. Eicholtz
Regional Sales Representative
KIDDE FIRE TRAINERS, INC.

This document and subsequent pages include information that is proprietary to Kidde Fire Trainers, LLC and shall not be disclosed outside of the addressee's organization and shall not be duplicated, used or disclosed - in whole or in part - for any reason other than to evaluate our offering.

Budgetary Price Proposal

Item	Description	Price
1	<p>O-100 Controls and Pilot Box</p> <ul style="list-style-type: none"> ▪ Independent pilot burner ▪ Two-stage main flame ▪ Handheld operator control pendant with 30' cable ▪ 50-ft AC power cable ▪ All required propane hoses and regulators ▪ Aluminum hose guards <p><u>Logistics & Support</u></p> <ul style="list-style-type: none"> ▪ Operation and maintenance manual ▪ One year standard warranty ▪ 24/7 technical phone support 	\$ 12,950
1A	<p>O-100 Burn Pan (24 sq. ft.)</p> <ul style="list-style-type: none"> ▪ Stainless steel ▪ water bath burn platform ▪ 4' x 6' burn area ▪ 60,000.000 btu/hr - high fire output capacity 	\$ 5,250
	Options	
2	O-100 Car mock-up (to be used with existing pilot box & accessories from O-100 Pan - Item #1)	\$27,900
3	O-100 Propane Tank mock-up (to be used with existing pilot box & accessories from O-100 Pan - Item #1)	\$6,900
4	O-100 Dual Split Pipe Flange Prop (to be used with existing pilot box & accessories from O-100 Pan - Item #1)	\$ 9,800
5	O-100 Propane Cylinder Prop – (3 x 100 lbs.) (to be used with existing pilot box & accessories from O-100 Pan - Item #1)	\$3,950
6	O-100 Christmas Tree Prop (to be used with existing pilot box & accessories from O-100 Pan - Item #1 and Item#1A)	\$ 4,500
7	Motor Generator Prop (to be used with existing pilot box & accessories from O-100 Pan – Item #1 and Item #1A)	\$ 4,150
8	Electrical Transformer - O-100 (to be used with existing pilot box & accessories from O-100 Pan - Item #1 and Item #1A)	\$ 4,150

Price Validity

Prices valid until 31 July 2016.
 Kidde's Standard Terms & Conditions apply to any resulting order.

Preferred Payment Terms

Kidde will invoice at the following milestones. Net 30 days.

- 30% invoiced upon order
- 70% invoiced upon shipment of the trainer to site

Kidde welcomes the opportunity to negotiate payment terms.

Delivery

180 days after acceptance of an order.



Kidde Fire Trainers

A UTC Fire & Security Company



CAR FIRETRAINER® O-100

Fully Portable

Easy to Operate

Easy to Maintain

No Infrastructure Required



fully involved car fire



Hose Line FIRETRAINER® O-100



car prop on trailer with propane storage tanks

Kidde Fire Trainers, Inc.
17 Philips Parkway
Montvale, NJ 07645-1810 USA
Tel +1 201-300-8100
Fax +1 201-300-8101
www.kiddeft.com

Kidde Fire Trainers
Unit 1a Midland Place
Barlborough Links
Barlborough
Derbyshire S43 4XA England
Tel: +44 (0) 1246 819755
Fax: +44 (0) 1246 575688
sales@kiddeft.com

The Car FIRETRAINER® O-100 is extremely versatile, giving users the ability to produce scenarios such as:

- engine fire
- forward passenger area fire
- rear passenger area fire
- fuel spill fire (optional)

A stainless steel water-cooled sub-frame assembly makes the Car Fire Prop extremely robust. Combining this with the stainless steel waterbath burner design provides unparalleled durability and ease of maintenance. The Car FIRETRAINER® burns environmentally acceptable propane. Safety is paramount with the ignition officer controlling a "deadman" button on the control pendant that when released instantly stops the fire.

Kidde's FIRETRAINER® O-100 systems are certified to UL safety standards by Intertek (ETL), a Nationally Recognized Testing Laboratory (NRTL).



Specifications

- construction welded steel mockup; stainless steel water bath burners and stainless steel water-cooled sub-frame assembly
- dimensions Car: 12.5'L x 5'W x 4.5'H (minimum)
Spill: 4' x 6' (burn area)
- power 110VAC (50' AC power cable provided)

Warranty & Support

- 12-month parts warranty with toll-free support

Features

- independent constant pilot flame
- two-stage main flame control
- hand-held operator control pendant with 30' cable
- 1.5" FD connection for cooling water

Options

- aluminum flat-deck transportation trailer
- wireless controls
- 12VDC to 110VAC inverter

© 2011, Kidde Fire Trainers
All rights reserved. Rev 10/2011
Copying or reproduction in any medium is strictly prohibited.

The Bristol Va. Fire Dept.

2016 Training Calendar

The BVFD training schedule is a flexible schedule. There is a monthly topic to be covered but not limited as the only material to be covered. During the month there are several other categories to be covered as Driver Training, Preplans, Tours and Fire Suppression Techniques. Each monthly category is to be covered by Fire Essentials 6th edition. All objectives and skills are to be covered and utilized at the training center. Quarterly training will cover all Haz-Mat and HTR training.

January – Building Construction

February – SCBA/PPE

March – Fire Behavior/ Haz-Mat quarterly training. (VDEM), Day Burn Shift Training

April – Mayday Drills, Search & Rescue, Physical Agility Test

May – Haz-Mat Drill & Quarterly Training, HTR Rope Training, Night Burn

June - Water Supply, Attack Lines, Monitor Deployment

July – Heat Emergencies

August – Forcible Entry, HTR Confine Space

September – Ladders, Night Burn Drill

October – Mayday Drills, Physical Agility Test

November – Fire Origin & Cause, HTR Vehicle, Day Burn

December – Fire Protection, Holiday Emergencies



General Instructions & Notices

- Applicants are directed to "**Regional Fire Services Training Facilities Grant Program Policy**" as amended for the current funding year which is incorporated by reference to all applications and any subsequent awards. (Such practices document is inclusive of all *terms & conditions*.)
- The filing of an application does not bind the Board to award nor the Department to pay any such grant.
- Incomplete applications and those received after the deadline will not be considered.
(Deadline) → **March 1, 2016** postmarked
- Completed applications executed by the competent authority will only be accepted directly from jurisdictions not fire departments.
- Timeliness of filing and subsequent receipt by the Agency are solely the applicant's responsibility – all applications must be completed in ink and sent directly to: **VDFP Grants and Local Aid Manager,**
Address → 1005 Technology Park Drive, Glen Allen VA 23059-4500
- All decisions regarding grant awards made by the Board are final; applicants may appeal decisions in writing to the address provided above within 15 business days of the posting of awards.

A. Applicant Information

1. Title of Lead Jurisdiction Making Application (Check <input checked="" type="checkbox"/> only one, then make entry)	<input checked="" type="checkbox"/> County of Accomack
	<input type="checkbox"/> City of
	<input type="checkbox"/> Incorporated Town of
2. Employer Identification Number (EIN)	[REDACTED]
3. Principal Point of Contact	(include salutation, name & title.) Charles R. Pruitt, Director of Public Safety
4. Mailing Address (Include zip code) Identify COUNTY if appropriate	PO Box 102 24420 Lankford Highway Tasley, Va 23441
5. Telephone Number	(757) 789-3610
6. FAX Number	(757) 789-3063
7. Internet e-mail address	cpruitt@co.accomack.va.us

B. Additional Parties

	Identify ALL jurisdictions (Not Fire Departments) participating in the proposed project. Attach additional sheets as may be required.
1. Formal Agreement Among Parties	In accordance with Program Policy, multi-jurisdictional regional training partnerships must be documented (e.g. MOA, MOU, etc.) as required supporting documentation to the Application for consideration of Program funding. A copy of the Agreement has been attached to this application. <input checked="" type="checkbox"/> Yes <input type="checkbox"/> No <i>If a copy of the Agreement has not been attached as required supporting documentation, this Application will be considered incomplete and funding will not be approved.</i>

Department of Fire Programs

FEB 26 2016

Administration



Department of Fire Programs

(Reproduce and complete as many additional blocs as may be necessary for complete disclosure.)

2a. Complete <u>one each</u> for ALL other Parties of Interest	Number <input type="text" value="1"/> of a total of <input type="text" value="16"/> parties to proposed project <small>(Count the LEAD Locality as #1, thereby start with #2.)</small>
2b. Title of Jurisdiction <small>(Check <input checked="" type="checkbox"/> only one, then make entry)</small>	<input checked="" type="checkbox"/> County of <input type="text" value="Accomack County"/> <input type="checkbox"/> City of _____ <input type="checkbox"/> Incorporated Town of _____
2c. Employer Identification Number (EIN)	<input type="text" value="██████████"/>
2d. Principal Point of Contact <small>(Include salutation, name & title.)</small>	<input type="text" value="Charles Pruitt, Director of Public Safety"/>
2e. Mailing Address <small>(Include zip code+4)</small> <small>Identify COUNTY if appropriate →</small>	<input type="text" value="PO Box 102"/> <input type="text" value="Tasley, Virginia 23441"/> <input type="text" value="Accomack County"/>
2f. Telephone Number	(757) <input type="text" value="789-3610"/>
2g. FAX Number	(757) <input type="text" value="789-3063"/>
2h. Internet e-mail address	<input type="text" value="cpruitt@co.accomack.va.us"/>

(Reproduce and complete as many additional blocs as may be necessary for complete disclosure.)

2a. Complete <u>one each</u> for ALL other Parties of Interest	Number <input type="text" value="1"/> of a total of <input type="text" value="6"/> parties to proposed project <small>(Count the LEAD Locality as #1, thereby start with #2.)</small>
2b. Title of Jurisdiction <small>(Check <input checked="" type="checkbox"/> only one, then make entry)</small>	<input checked="" type="checkbox"/> County of <input type="text" value="Northampton County"/> <input type="checkbox"/> City of _____ <input type="checkbox"/> Incorporated Town of _____
2c. Employer Identification Number (EIN)	<input type="text" value="██████████"/>
2d. Principal Point of Contact <small>(Include salutation, name & title.)</small>	<input type="text" value="Charles Pruitt Director of Public Safety"/>
2e. Mailing Address <small>(Include zip code+4)</small> <small>Identify COUNTY if appropriate →</small>	<input type="text" value="PO Box 102"/> <input type="text" value="Tasley, Va 23441"/> <input type="text" value="Accomack County"/>
2f. Telephone Number	() <input type="text" value=""/>
2g. FAX Number	() <input type="text" value=""/>
2h. Internet e-mail address	<input type="text" value=""/>

(Reproduce and complete as many additional blocs as may be necessary for complete disclosure.)

2a. Complete <u>one each</u> for ALL other Parties of Interest	Number <input type="text" value=""/> of a total of <input type="text" value=""/> parties to proposed project <small>(Count the LEAD Locality as #1, thereby start with #2.)</small>
2b. Title of Jurisdiction <small>(Check <input checked="" type="checkbox"/> only one, then make entry)</small>	<input type="checkbox"/> County of _____ <input type="checkbox"/> City of _____ <input type="checkbox"/> Incorporated Town of _____
2c. Employer Identification Number (EIN)	<input type="text" value="██████████"/>
2d. Principal Point of Contact <small>(Include salutation, name & title.)</small>	<input type="text" value=""/>
2e. Mailing Address <small>(Include zip code+4)</small> <small>Identify COUNTY if appropriate →</small>	<input type="text" value=""/>
2f. Telephone Number	() <input type="text" value=""/>
2g. FAX Number	() <input type="text" value=""/>
2h. Internet e-mail address	<input type="text" value=""/>



C. Previous Applications/Awards

1.	Has the Applicant previously applied for a RFSTF Grant from the Board? - check <input checked="" type="checkbox"/> one	<input checked="" type="checkbox"/> No	<input type="checkbox"/> Yes
2.	Has the Applicant previously received a RFSTF Grant from the Board? - check <input checked="" type="checkbox"/> one	<input checked="" type="checkbox"/> No	<input type="checkbox"/> Yes

D. Project Title(s) and Description(s) Enter a descriptive 'Title' and brief Description for the lead training project and/or program proposed for funding from any Grant which may be awarded pursuant to this application.

(Project Title)	(Description)
1 Car Fire Trainer 0-100	The car fire trainer is designed for training reponse personnel in vehicle fire emergencies wich include engine fires, forward passenger area fires, rear passenger area fires, fuel spill fires

Which statement best describes the above proposed project and/or program? check one

New **Change** to existing **Continuing**

Which statement best describes how many training programs may benefit from the proposal? check one

Multiple Programs **Single Program**

Describe the impact on training if this Grant is not awarded, or check **No Significant Impact**

The Fire Training Center will replace the existing vehicle with another vehicle allotted from the county garage.

The purpose of this request is to replace the existing prop with a more efficient prop.

← Check IF a Continuation D Sheet is used to account for **more than one (1) project / program**.
IMPORTANT, if box above is checked and no continuation sheets are attached, the application will not be further considered.

E. Project Goods & Services Requested In the below table, itemize in priority order – starting with the most needed first, ALL items of "Goods" (e.g. equipment, hardware or other durable items) or categories of "Services" which are to be funded in whole or in part from any Grant which may be awarded pursuant to this application.

Enter Project Title from [D] above	Check <input checked="" type="checkbox"/> One	Description	Total Cost	Less any Matching Funds	Grant Amount Requested
1	<input checked="" type="checkbox"/> Goods <input type="checkbox"/> Services	Stainless steel water cooled sub frame assembly	(a)	(b)	(a-b)
		makes the Car Fire Prop structure. The Car Fire Props burns LP Gas.	\$ 30,500.00	\$ -	\$ 30,500.00
2	<input type="checkbox"/> Goods <input type="checkbox"/> Services		(a)	(b)	(a-b)
			\$ -	\$ -	\$ -
3	<input type="checkbox"/> Goods <input type="checkbox"/> Services		(a)	(b)	(a-b)
			\$ -	\$ -	\$ -
4	<input type="checkbox"/> Goods <input type="checkbox"/> Services		(a)	(b)	(a-b)
			\$ -	\$ -	\$ -
5	<input type="checkbox"/> Goods <input type="checkbox"/> Services		(a)	(b)	(a-b)
			\$ -	\$ -	\$ -

← Check IF a Continuation D Sheet is used to account for **more than one (1) project / program**.
IMPORTANT, if box above is checked and no continuation sheets are attached, the application will not be further considered.

E	Enter here the lesser amount of:	\$ 30,500 -
	<ul style="list-style-type: none"> • Sum of all items (1 thru n) under "Grant Amount Requested" • OR \$50,000 (Grant maximum) 	

Department of Fire Programs
 Administration
 Feb 26 2016



F. Matching/Cost Share

1	Which statement best describes the matching funds contributions? <i>check <input checked="" type="checkbox"/> one</i>	<input type="checkbox"/> 50% or More	<input type="checkbox"/> Less than 50%	<input checked="" type="checkbox"/> None
---	--	--------------------------------------	--	--

G. ATL Funding

1	What is the amount of the Applicant's FY-2015 Aid to Localities (ATL) allocation from the Fire Programs Fund? <i>check <input checked="" type="checkbox"/> one and complete as necessary</i>	<input type="checkbox"/> \$10,000 or \$20,000 exactly	<input checked="" type="checkbox"/> Other - Enter amount here	\$ 75,855.00
---	---	---	---	--------------

2	Did the Applicant have cash carry forward from FY-2015 into FY-2016 from previous years' Aid to Localities (ATL) allocations? <i>check <input checked="" type="checkbox"/> one and complete as necessary</i>	<input checked="" type="checkbox"/> Yes	<input type="checkbox"/> No	If "Yes", amount of FY-2015 ATL carry forward: \$ 12,942.46
---	---	---	-----------------------------	---

Remarks	Make entries or check <input checked="" type="checkbox"/> <input type="checkbox"/> None	Important If the sum (1 to n) of individual "Grant Amount. Requested" in E above exceeded \$50,000, an explanation must be entered here as to how the shortfall would otherwise be made up.

EFT (EDI)

Grant awards are paid as an **Electronic Funds Transfer / EDI** to the current account-of-record for the jurisdiction's annual allocation of Aid to Localities (ATL) from the Fire Programs Fund.

Certification:

To be completed by either:

- County Administrator –or- Executive, City Manager, Town Mayor –or- Administrator; Deputy, or...
- Other duly authorized official whereby the application is accompanied by a copy of an 'Ordinance' or other such formal instrument clearly granting that party such authority.

This grant application is entered on behalf of the APPLICANT jurisdiction identified above with the knowledge and belief that all representations herein made are true and correct; with the understanding that all grant terms & conditions in-force as of the date of such application are hereby included by reference; with the further understanding that if an award is granted pursuant to this application that the recipient is bound by those same terms & conditions.

Signature: *[Handwritten Signature]* Date: *02/23/16*
 Printed Name: STEVEN B. MINER Title: County Administrator

(All applications must be notarized to be considered – incomplete forms shall be returned.)

State of Virginia }
 City/County of Virginia }

On this 23rd day of Feb. (month) in 2016 (year), before me, the undersigned a Notary Public for the Commonwealth of Virginia, personally appeared STEVEN B. MINER to me known (or to me proved) to be the identical person named herein and having in my presence executed the above, and acknowledged that he executed same as his voluntary act and deed.

My Commission expires: 10/31/2016 Date *[Handwritten Signature]* Notary Public (Seal)

YVONNE N. PENNELL
 REGISTRATION #100402
 NOTARY PUBLIC
 COMMONWEALTH OF VIRGINIA
 MY COMMISSION EXPIRES
10/31/16

Administration

FEB 26 2016

Department of Fire Programs



County of Accomack Department of Public Safety

"Together We Make a Difference"

www.co.accomack.va.us
www.acdps.net

Fire & Rescue ~ Emergency Management

February 5, 2016

Virginia Department of Fire Programs
1005 Technology Park Drive
Glen Allen VA 23059-4500

Dear Grants Administrator:

Please accept this letter on behalf of both Accomack and Northampton Counties. Each county recognizes the Eastern Shore Regional Fire Training Center as the facility of choice to provide fire and EMS training for the first responders of the Eastern Shore.

Thank you for your consideration of this project.

Respectfully,

Dr. Steve Miner, Administrator
Accomack County
PO BOX 388
Accomack VA 23301

Katherine H. Nunez, Administrator
Northampton County
PO BOX 66
Eastville VA 23347

Letters/VDFP - Regional Fire Training Center Grant - 160205

Kidde Fire Trainers



CAR FIRETRAINER® O-100

Fully Portable

Easy to Operate

Easy to Maintain

No Infrastructure Required



fully involved car fire



Hose Line FIRETRAINER® O-100



car prop on trailer with propane storage tanks

Kidde's Car FIRETRAINER® O-100 is designed for training response personnel in vehicle fire emergencies. Kidde's integral multi-zone burner design allows users to simulate numerous vehicle fire scenarios at the push of a button. Additionally, an adjacent Hose Line FIRETRAINER® O-100 (optional) can provide trainees with exposure to simulated leaking fuel fire emergencies.

The Car FIRETRAINER® O-100 is extremely versatile, giving users the ability to produce scenarios such as:

- engine fire
- forward passenger area fire
- rear passenger area fire
- fuel spill fire (optional)

A stainless steel water-cooled sub-frame assembly makes the Car Fire Prop extremely robust. Combining this with the stainless steel waterbath burner design provides unparalleled durability and ease of maintenance. The Car FIRETRAINER® burns environmentally acceptable propane. Safety is paramount with the ignition officer controlling a "deadman" button on the control pendant that when released instantly stops the fire.

Kidde's FIRETRAINER® O-100 systems are CSA certified and certified to UL safety standards by Intertek (ETL), a Nationally Recognized Testing Laboratory (NRTL).



Specifications

- construction welded steel mockup; stainless steel water bath burners and stainless steel water-cooled sub-frame assembly
- dimensions Car: 12.5'L x 5'W x 4.5'H (minimum)
Spill: 4' x 6' (burn area)
- power 110VAC (50' AC power cable provided)

Warranty & Support

- 12-month parts warranty with toll-free support

Features

- independent constant pilot flame
- two-stage main flame control
- hand-held operator control pendant with 30' cable
- 1.5" FD connection for cooling water

Options

- aluminum flat-deck transportation trailer
- wireless controls
- 12VDC to 110VAC inverter

Kidde Fire Trainers, LLC
17 Philips Parkway
Montvale, NJ 07645-1810
USA
Tel +1 201-300-8100
Fax +1 201-300-8101
info-us@kiddeftr.com
www.kiddeftr.com

Kidde Fire Trainers GmbH - UK
Unit 1a Midland Place
Barlborough Links
Barlborough S43 4XA UK
Tel: +44 (0) 1246 819755
Fax: +44 (0) 1246 5756-88
info-uk@kiddeftr.com

Kidde Fire Trainers GmbH
Sonnenweg 13
52070 Aachen
Germany
Tel +49 (0) 241 18058-11
Fax +49 (0) 241 18058-280
info-eu@kiddeftr.com
www.firetrainer.de

©2014, Kidde Fire Trainers
All rights reserved Rev 7/2014
Copying or reproduction in any
medium is strictly prohibited.

Kidde Fire Trainers LLC
17 Philips Parkway
Montvale, NJ 07645-1810 USA
Tel +1 201.300.8100
Fax +1 201.300.8101
www.kiddefit.com



Q7087-JE-10Dec2015

Via: djones@co.accomack.va.us

Mr. Doug Jones
Accomack Dept of Public Safety
24420 Lankford Hwy,
Tasley, VA 23441

(757) 789 3610

Subject: Budgetary Proposal for a Kidde FIRETRAINER® Systems

Dear Mr. Jones,

Kidde Fire Trainers, is pleased to provide this budgetary price proposal for an O-100 Car mock-up for your consideration.

We welcome the opportunity to discuss this proposal and can revise the options to your needs.

Please do not hesitate to contact me at (410) 256-3126 with any questions. We look forward to fulfilling your fire training needs.

Sincerely,

James R. Eicholtz

James R. Eicholtz
Regional Sales Representative
KIDDE FIRE TRAINERS LLC

This document and subsequent pages include information that is proprietary to Kidde Fire Trainers, LLC and shall not be disclosed outside of the addressee's organization and shall not be duplicated, used or disclosed - in whole or in part - for any reason other than to evaluate our offering.

Budgetary Price Proposal

Item	Description	Price
1	O-100 Car mock-up (to be used with existing pilot box & accessories from the existing O-100 system at the customer site) <ul style="list-style-type: none">▪ Carbon steel Car mockup on functioning wheels▪ Stainless steel Sub-frame with water cooling. 1 1/2" FD connection▪ Integral burners with three burn zones:<ul style="list-style-type: none">- Engine Fire- Forward Passenger Area Fire- Rear Passenger Area Fire▪ Workable hood, trunk and doors▪ Driver & Passenger Seat Mockups▪ Steering Wheel Mockup▪ Logistics: to be delivered and installed by a Kidde FT technician and integrated to the existing O-100 system▪ One year warranty on parts▪ Total weight is 3300lbs	\$27,500
2	Freight (estimated, to be billed at actual cost)	\$3,000

Price Validity

Prices valid for 90 days.

Kidde's Standard Terms & Conditions apply to any resulting order.

\$30,500.00

Preferred Payment Terms

Kidde will invoice at the following milestones. Net 30 days.

- 30% invoiced upon order
- 70% invoiced upon shipment of the trainer to site

Kidde welcomes the opportunity to negotiate payment terms.

Delivery

180 days after acceptance of an order.

Exclusions

Prices exclude the cost of a payment and performance bond, permits, and any local and state sales taxes that may be applicable.



General Instructions & Notices

- Applicants are directed to "**Regional Fire Services Training Facilities Grant Program Policy**" as amended for the current funding year which is incorporated by reference to all applications and any subsequent awards. (Such practices document is inclusive of all *terms & conditions*.)
- The filing of an application does not bind the Board to award nor the Department to pay any such grant.
- Incomplete applications and those received after the deadline will not be considered.
(Deadline) → **March 1, 2016** postmarked
- Completed applications executed by the competent authority will only be accepted directly from jurisdictions not fire departments.
- Timeliness of filing and subsequent receipt by the Agency are solely the applicant's responsibility – all applications must be completed in ink and sent directly to: **VDFP Grants and Local Aid Manager**,
Address → 1005 Technology Park Drive, Glen Allen VA 23059-4500
- All decisions regarding grant awards made by the Board are final; applicants may appeal decisions in writing to the address provided above within 15 business days of the posting of awards.

A. Applicant Information

1. Title of Lead Jurisdiction Making Application (Check <input checked="" type="checkbox"/> only one, then make entry)	<input checked="" type="checkbox"/>	County of	Botetourt
		City of	
		Incorporated Town of	
2. Employer Identification Number (EIN)	[REDACTED]		
3. Principal Point of Contact	(Include salutation, name & title.) Mr. Robert L. Johnson, Jr., Battalion Chief - Training		
4. Mailing Address (Include zip code) Identify COUNTY if appropriate	205 N. Roanoke St. Suite 1 Fincastle, VA 24090		
5. Telephone Number	(540) 529-0662		
6. FAX Number	(540) 473-8288		
7. Internet e-mail address	rjohnson@botetourtva.gov		

B. Additional Parties

	Identify ALL jurisdictions (Not Fire Departments) participating in the proposed project. Attach additional sheets as may be required.		
1. Formal Agreement Among Parties	<p>In accordance with Program Policy, multi-jurisdictional regional training partnerships must be documented (e.g. MOA, MOU, etc.) as required supporting documentation to the Application for consideration of Program funding.</p> <p>A copy of the Agreement has been attached to this application. <input checked="" type="checkbox"/> Yes <input type="checkbox"/> No</p> <p><i>If a copy of the Agreement has not been attached as required supporting documentation, this Application will be considered incomplete and funding will not be approved.</i></p>		

Department of Fire Programs

MAR 04 2016

Administration



MAR 04 2016

{ Reproduce and complete as many additional blocs as may be necessary for complete disclosure. }

2a. Complete <u>one each</u> for ALL other Parties of Interest	Number <input type="text" value="2"/> of a total of <input type="text" value="4"/> parties to proposed project <small>(Count the LEAD Locality as #1, thereby start with #2.)</small>	
2b. Title of Jurisdiction <small>(Check <input checked="" type="checkbox"/> only one, then make entry)</small>	<input type="checkbox"/> County of _____	
	<input type="checkbox"/> City of _____	
	<input checked="" type="checkbox"/> Incorporated Town of Fincastle	
2c. Employer Identification Number (EIN)	[REDACTED]	
2d. Principal Point of Contact	<small>(Include salutation, name & title.)</small> Mr. David Tickner, AICP, Town Manager	
2e. Mailing Address <small>Identify COUNTY if appropriate -</small>	<small>(Include zip code+4)</small> P.O. Box 250 Fincastle, VA 24090 Botetourt County	
2f. Telephone Number	<small>(work)</small> (540) 473-2200	
2g. FAX Number	<small>(cell)</small> (540) 293-4432	
2h. Internet e-mail address	davidtickner@townoffincastle.org	

{ Reproduce and complete as many additional blocs as may be necessary for complete disclosure. }

2a. Complete <u>one each</u> for ALL other Parties of Interest	Number <input type="text" value="3"/> of a total of <input type="text" value="4"/> parties to proposed project <small>(Count the LEAD Locality as #1, thereby start with #2.)</small>	
2b. Title of Jurisdiction <small>(Check <input checked="" type="checkbox"/> only one, then make entry)</small>	<input type="checkbox"/> County of _____	
	<input type="checkbox"/> City of _____	
	<input checked="" type="checkbox"/> Incorporated Town of Troutville	
2c. Employer Identification Number (EIN)	[REDACTED]	
2d. Principal Point of Contact	<small>(Include salutation, name & title.)</small> Mr. David Horton, Mayor	
2e. Mailing Address <small>Identify COUNTY if appropriate -</small>	<small>(Include zip code+4)</small> 5419 Lee Highway / P.O. Box 276 Troutville, VA 24175 Botetourt County	
2f. Telephone Number	<small>(work)</small> (540)992-4401	
2g. FAX Number	<small>()</small>	
2h. Internet e-mail address	tville@rbnet.com	

{ Reproduce and complete as many additional blocs as may be necessary for complete disclosure. }

2a. Complete <u>one each</u> for ALL other Parties of Interest	Number <input type="text" value="4"/> of a total of <input type="text" value="4"/> parties to proposed project <small>(Count the LEAD Locality as #1, thereby start with #2.)</small>	
2b. Title of Jurisdiction <small>(Check <input checked="" type="checkbox"/> only one, then make entry)</small>	<input type="checkbox"/> County of _____	
	<input type="checkbox"/> City of _____	
	<input checked="" type="checkbox"/> Incorporated Town of Buchanan	
2c. Employer Identification Number (EIN)	[REDACTED]	
2d. Principal Point of Contact	<small>(Include salutation, name & title.)</small> Mrs. Mary Zirkle, Town Manager	
2e. Mailing Address <small>Identify COUNTY if appropriate -</small>	<small>(Include zip code+4)</small> 19753 Main Street / P.O. Box 205 Buchanan, VA 24066 Botetourt County	
2f. Telephone Number	<small>(work)</small> (540) 254-1212	
2g. FAX Number	<small>()</small>	
2h. Internet e-mail address	mzirkle@buchanan-va.gov	



Department of Fire Programs
 Administration
 MAR 04 2016

C. Previous Applications/Awards

1.	Has the Applicant previously applied for a RFSTF Grant from the Board? - check <input checked="" type="checkbox"/> one	<input checked="" type="checkbox"/> No	<input type="checkbox"/> Yes
2.	Has the Applicant previously received a RFSTF Grant from the Board? - check <input checked="" type="checkbox"/> one	<input checked="" type="checkbox"/> No	<input type="checkbox"/> Yes

D. Project Title(s) and Description(s)

Enter a descriptive 'Title' and brief Description for the lead training project and/or program proposed for funding from any Grant which may be awarded pursuant to this application.

1	Botetourt Entry Level and Advanced Fire Training Enhancement Program	We currently provide and assist with entry level (FFI & FFII) and continuing/ advanced level fire training for prospective and current firefighters throughout Botetourt County. We are seeking to acquire live fire and simulated fire props to greatly enhance the realism we are able to provide in training.
Which statement best describes the above proposed project and/or program? check <input checked="" type="checkbox"/> one		<input type="checkbox"/> New <input type="checkbox"/> Change to existing <input checked="" type="checkbox"/> Continuing
Which statement best describes how many training programs may benefit from the proposal? check <input checked="" type="checkbox"/> one		<input checked="" type="checkbox"/> Multiple Programs <input type="checkbox"/> Single Program
Describe the impact on training if this Grant is not awarded, or check <input type="checkbox"/> No Significant Impact		
If this grant is not awarded, we will still be able to conduct entry and advance training, but will not be able to provide the realism in training that we are seeking to provide for both our entry and advanced level fire training programs. We currently do not have a burn building or any live fire props to give our students and current firefighters realistic scenarios in training.		
<input type="checkbox"/> Check <input checked="" type="checkbox"/> IF a Continuation D Sheet is used to account for more than one (1) project / program.		
IMPORTANT, if box above is checked and no continuation sheets are attached, the application will not be further considered.		

E. Project Goods & Services Requested

In the below table, itemize in priority order – starting with the most needed first, ALL items of "Goods" (e.g. equipment, hardware or other durable items) or categories of "Services" which are to be funded in whole or in part from any Grant which may be awarded pursuant to this application.

Enter Project Title from [D] above	Check <input checked="" type="checkbox"/> One	Description	Total Cost	Less any Matching Funds	Grant Amount Requested
1	<input checked="" type="checkbox"/> Goods	BullEx Hoseline Training System Consists of: Fire Tray, Pilot Control Box, & Mobile Control Console This is the base package of BullEx's modular system that uses propane to create fire scenarios	(a) \$ 18,995.00	(b) \$ -	(a-b) \$ 18,995.00
2	<input checked="" type="checkbox"/> Goods	Stove Fire Training Prop Used in conjunction with the BullEx Hoseline Training system to create a live fire scenario with a stove prop	(a) \$ 11,995.00	(b) \$ -	(a-b) \$ 11,995.00
3	<input checked="" type="checkbox"/> Goods	Propane Cylinder Fire Training Prop Used in conjunction with the BullEx Hoseline Training system to create a live fire scenario with LP / propane gas tank props	(a) \$ 2,995.00	(b) \$ -	(a-b) \$ 2,995.00
4	<input checked="" type="checkbox"/> Goods	BullEx Attack Digital Fire Training System Base Package A portable unit that creates the look and sound of active fire, can be hit with either water from a hose-line or the digital signal from the digital nozzle Used in conjunction with BullEx smoke generators	(a) \$ 9,985.00	(b) \$ -	(a-b) \$ 9,985.00
5	<input checked="" type="checkbox"/> Goods	Digital Nozzle & Weighted Fire Hose Can be used in conjunction with the BullEx Attack Digital Fire Training System in areas where water cannot be flowed.	(a) \$ 3,500.00	(b) \$ -	(a-b) \$ 3,500.00

Check IF a Continuation D Sheet is used to account for more than one (1) project / program.
IMPORTANT, if box above is checked and no continuation sheets are attached, the application will not be further considered.

E	Enter here the lesser amount of: • Sum of all items (1 thru n) under "Grant Amount Requested" • OR \$50,000 (Grant maximum)	\$ 50,000.00
----------	---	---------------------

Continuation Sheet E - Side 1

E In the below table itemize in priority order – starting with the most needed first, **ALL** items of "Goods" (e.g. equipment, hardware or other durable items) or categories of "Services" which are to be funded in whole or in part from any Grant which may be awarded pursuant to this application.

Enter Project Number from [D] above	Check <input checked="" type="checkbox"/> One	Description	Total Cost	Less any Matching Funds	Grant Amount Requested
6	<input checked="" type="checkbox"/> Goods	Waterproof Case for BullEx 4000 Smoke Generator	(a)	(b)	(a-b)
		Will allow us to use our BullEx 4000 smoke generator that we purchased this year in conjunction with the Digital Attack System for added realism	\$ 1,895.00	\$ -	\$ 1,895.00
7	<input checked="" type="checkbox"/> Services	Installation, Set-up, Training	(a)	(b)	(a-b)
		1. Delivery of the props listed above	align="right">\$ 2,865.41	align="right">\$ -	align="right">\$ 2,865.41
		2. Initial set-up & calibration of above listed props			
3. 4-hour Train-the-Trainer for up to 10 personnel on above listed props					
8	<input type="checkbox"/> Goods		(a)	(b)	(a-b)
			\$ -	\$ -	\$ -
9	<input type="checkbox"/> Services		(a)	(b)	(a-b)
			\$ -	\$ -	\$ -
10	<input type="checkbox"/> Goods		(a)	(b)	(a-b)
			\$ -	\$ -	\$ -
11	<input type="checkbox"/> Services		(a)	(b)	(a-b)
			\$ -	\$ -	\$ -
12	<input type="checkbox"/> Goods		(a)	(b)	(a-b)
			\$ -	\$ -	\$ -

Be sure that the total of ALL "Grant Amount Requested" entries are properly accounted for in the final line of Section E of your application. Also, be sure that if this continuation work sheet is used, your application is both properly marked and this sheet is included with your filing of the application.

Continuation Sheet E - Side 2

	<input type="checkbox"/> Goods		(a)	(b)	(a-b)
--	--------------------------------	--	-----	-----	-------



F. Matching/Cost Share

1 Which statement best describes the matching funds contributions?
check one

50% or More Less than 50% None

G. ATL Funding

1 What is the amount of the Applicant's FY-2015 Aid to Localities (ATL) allocation from the Fire Programs Fund?
check one and complete as necessary

\$10,000 or \$20,000 exactly
 Other - Enter amount here \$98,802

2 Did the Applicant have cash carry forward from FY-2015 into FY-2016 from previous years' Aid to Localities (ATL) allocations?
check one and complete as necessary

Yes No

If "Yes", amount of FY-2015 ATL carry forward: N/A

Make entries or check None

Remarks

The overall of the program cost (estimated to be approximately \$2,230,411, which covers its major of training and set-up for the requested training program) will be covered by monies from Botetourt Fire-EMS's FY-2017 training budget monies (2017)

Total Estimated Cost of Training Enhancement Plan: \$52,230.41.

Important - If the sum (1 to n) of individual "Grant Amount. Requested" in E above exceeded \$50,000, an explanation must be entered here as to how the shortfall would otherwise be made up.

EFT (EDI)

Grant awards are paid as an Electronic Funds Transfer / EDI to the current account-of-record for the jurisdiction's annual allocation of Aid to Localities (ATL) from the Fire Programs Fund.

Certification:

To be completed by either:

- County Administrator -or- Executive, City Manager, Town Mayor -or- Administrator; Deputy, or...
- Other duly authorized official whereby the application is accompanied by a copy of an 'Ordinance' or other such formal instrument clearly granting that party such authority.

This grant application is entered on behalf of the APPLICANT jurisdiction identified above with the knowledge and belief that all representations herein made are true and correct; with the understanding that all grant terms & conditions in-force as of the date of such application are hereby included by reference; with the further understanding that if an award is granted pursuant to this application that the recipient is bound by those same terms & conditions.

Gary Larowe Signature | 2-26-2016 Date
Gary Larowe Printed Name | Botetourt County Administrator Title

(All applications must be notarized to be considered -- incomplete forms shall be returned.)

State of Virginia }
 City / County of Botetourt }

On this 26 day of Feb. (month) in 2016 (year), before me, the undersigned a Notary Public for the Commonwealth of Virginia, personally appeared Gary Larowe to me known (or to me proved) to be the identical person named herein and having in my presence executed the above, and acknowledged that he executed same as his voluntary act and deed.

My Commission expires: Aug. 31, 2016 Date | Susan H. Fain Notary Public

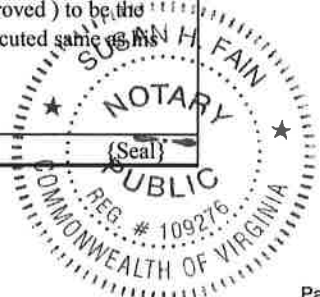

Botetourt County Fire Training Plan

Prepared by R. Johnson, Battalion Chief - Training

Scope: As the Authority Having Jurisdiction (AHJ), the County of Botetourt (through the Department of Fire-EMS) seeks to provide entry level fire training each year by requesting, overseeing, facilitating, and assisting with Department of Fire Programs Firefighter I and Firefighter II courses to interested personnel from local and regional fire departments, giving priority to personnel from fire departments within our county. This is in an effort to maintain an effective and competent fire suppression force throughout the county. The training benefits all of the localities within Botetourt County, including the incorporated towns of Troutville, Fincastle, and Buchanan, as well as unincorporated areas such as Eagle Rock, Glen Wilton, Daleville, Blue Ridge, and Read Mountain. The Department of Fire-EMS also seeks to keep certified and active career and volunteer personnel up to date and response ready through more advanced training in all aspects of fire / rescue operations including, but not limited to, fire attack principles, water supply, emergency vehicle operations, fireground safety, wildland firefighting, ICS, vehicle extrication, specialized rescue, hazardous materials, officer development, etc.

Part I

Meeting basic training needs:

The majority of the Firefighter I and II training is conducted at Troutville Volunteer Fire Department's *Fire Training Center* through a collaborative effort between the County and TVFD. The *Fire Training Center* is an old school building behind the TVFD fire station that has been converted into a non-live-fire training center. The building and grounds contains a clean classroom, dirty classroom, indoor mock house layout (including living room, kitchen, bedroom, bathroom, hoarder's room w/ debris), Denver Drill prop, Columbus Drill prop, 2nd story window prop, and SCBA maze trailer (acquired from Roanoke City Fire Department), forcible entry door simulator, and small pitched roof / vertical ventilation prop. Most of the tools (ladders, irons, power saws, hose, etc.) needed to conduct classes are utilized off of our reserve fire engine when it is not in use as a primary unit. When the reserve engine is not available, extra tools and equipment are utilized from response units from various departments in the county. SCBA and masks utilized by students, as well as most of the PPE, are usually provided by the student's home department. The TVFD training center also includes acquired props to

assist with training, such as a cut-away hydrant, rescue and utility rope display board, sprinkler heads, and electrical disconnect props. The vast majority of lectures take place in the clean classroom with most of the practical sessions taking place elsewhere on the grounds. Specifically:

Search & Rescue

Where: mock house layout

Equipment: mannikins, smoke machine, SCBA, hose

SCBA

Where: Dirty classroom, SCBA maze, mock house layout

Equipment: SCBA, PPE

Ladders

Where: 2-Story mock-up

Equipment: Single ladders, extension ladders, attic ladders

Hose

Where: Training grounds

Equipment: Various attack and supply hose from reserve engine

Portable Fire Extinguishers

Where: Training grounds

Equipment: Burn pan, fuel mixture, fusees, extinguishers rented from local supplier

Forcible Entry

Where: Forcible entry door simulator

Equipment: Irons, PPE, hearing and eye protection

Ropes & Knots

Where: Dirty classroom, training grounds

Equipment: Lengths of practice rope provided to students, tools for hoisting

Wildland Ground Cover Fires

Where: Field / Wooded area owned by the County

Equipment: Fire rakes, forestry hose, VDOF engine, fire shelters

Water Supply

Where: Training grounds

Equipment: Reserve engine, hose, hydrant, portable drop tank

Sprinklers

Where: Various places where sprinkler systems are installed

Equipment: sprinkler head props

Salvage

Where: Dirty classroom, training grounds

Equipment: salvage covers, tarps, pike poles, ladders, rolls of plastic

Overhaul

Where: Mock house layout

Equipment: Thermal Imaging Camera, pike poles, building construction prop

Final Live Burns

Where: Neighboring County's Burn Building (Roanoke County or Bedford County)

Equipment: Reserve engines, ambulance, PPE, SCBA, tools, ladders, hydrants,
hose, nozzles, etc.

Part 2

Multi-Jurisdictional Partnerships

*See attached Memorandum of Understanding regarding fire training between the County of Botetourt, Town of Troutville, Town of Fincastle, and Town of Buchanan.

Memorandum of Understanding

WHEREAS, Botetourt County Department of Fire & EMS is responsible for the operational oversight of all career and volunteer fire and EMS assets and personnel;

AND WHEREAS, for the betterment of the provision of fire and EMS services and the overall safety of personnel, the Department of Fire & EMS provides for training of all career and volunteer members.

AS SUCH, the County of Botetourt works directly with the incorporated town of Buchanan, Fincastle, and Troutville to ensure that all components of the system are well organized, proficient and competent in carrying out the duties for fire and EMS response personnel. This is done through organized training programs that are coordinated, conducted, and often funded by the County of Botetourt.

AFFIRMATION:

As an authorized agent for my respective political subdivision, I affirm these statements and practices to be an accurate representation of the working relationship already in place with regards to fire and EMS training programs.

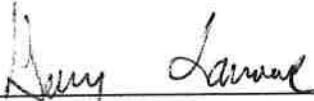

Gary Larrowe, County Administrator, Botetourt County

2-26-2016
Date

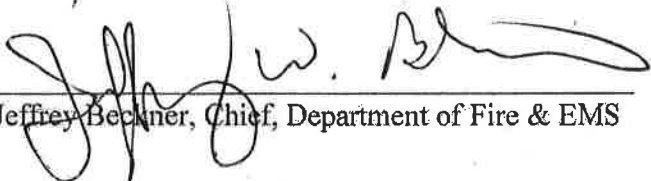

Jeffrey Beckner, Chief, Department of Fire & EMS

2/29/16
Date



Mary Zirkle, Town Manager, Town of Buchanan

2/26/16
Date



David Tickner, Town Manager, Town of Fincastle

2/26/16
Date

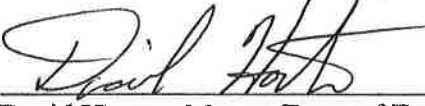

David Horton, Mayor, Town of Troutville

2/29/16
Date

Part 3

Training Enhancements Due to Requested Props

As you can see from the above training plan, we have at our disposal many good props and resources, most of which have come about through manual labor, acquisition of materials, and creativity. Most of the props we currently utilize are good for individual skills teaching and evaluation, but we lack good live fire training equipment and the overall ability to create realistic simulated environments that allow students and current firefighters to put all of their skills together in scenario based training and evolutions. Acquisition and utilization of the requested training props would greatly enhance our entry level training (Firefighter I & II) and our advanced level training.

Live Fire Props

BullEx Hoseline Modular Training System (Fire Tray, Pilot Control Box, Mobile Control Console)

Stove Fire Training Prop (modular addition to above system)

Propane Cylinder Fire Training Prop (modular addition to above system)

Benefits: Other than a burn pan, we currently have no live fire capabilities within the county. Often (with exception of fire extinguisher training with the burn pan), the live burn is the first time that students in Firefighter I class see and are faced with a respectable amount of live fire. The addition of this system would allow us to provide students and firefighters alike with live fire training (outdoors) with an amount of fire that can test their hose stream application, especially before Firefighter I students attend the required burn building burn. The base system and requested modules would allow us to simulate a fuel spill burn, LP gas burn, and burning stove/kitchen fire. The other benefit of this system is that it is modular and would allow us to add other modules in the future to simulate a wider range of fire scenarios (examples: vehicle fire module, dumpster module, gas meter module, electric motor module, barbeque grill module, etc.). The system is mobile and transportable which would meet our needs in providing live fire training across the county at the various volunteer fire/rescue stations. It is also very clean burning (propane), which would help reduce the residue and clean-up associated with the regular burn pan / fuel mixture prop we currently utilize, as well as being cleaner for the environment.

Simulated / Digital Fire Props

BullEx Digital *Attack* Training System (Base Package)

Digital Nozzle / Weighted Fire Hose

Waterproof Case for Smoke Generator (will allow us to use our recently purchased BullEx smoke generator with the Digital Attack system)

Benefits: As noted before, our county does not have a live-fire burn building. However, we sometimes are able to acquire structures for periods of time for non-live-fire training evolutions and training. We recently purchased a BullEx smoke generator to give those scenarios in acquired structures more realism. While this works okay for basic search & rescue and ventilation training, we are still lacking that realism of "live" fire. The BullEx Digital *Attack* system would help bring us one big step closer to achieving that realism without live fire. The Digital *Attack* system is portable, durable, simulates flame growth, steam generation after hose stream application, and interacts with the actual hose stream application techniques when water is actually flowed. When water cannot be flowed, use of the digital nozzle attachment allows students and firefighters to simulate water application and the *Attack* system will react accordingly. This feature further extends our training opportunities by allowing us to train in buildings where we are unable to flow water. This would be extremely valuable for entry and advanced firefighters alike. We would be able to use this system for Firefighter I & II training inside of the mock house layout at the Troutville fire training center before students attend the actual live fire scenarios at the burn building in a neighboring county.

Botetourt Fire-EMS

LARGE PROP FIRE TRAINING

Budgetary Proposal

2-23-2016



Quote Number: 85768
Date: 2-23-16
Sales Person: Kathy Plant
Valid Until: 4-23-16
Terms: See General Terms and Conditions

Contact: Rob Johnson
Address: 299 Dawnridge Lane
Troutville VA 24175
Phone: 540-529-0662



Background – Our Approach

Realism

BullEx Training Systems are designed to simulate every aspect of a fire or emergency response situation. The fire training systems, structures, and their interior props are constructed accurately to scale, and the fires are built into objects and appliances that would be found in real life. BullEx focuses on building the most realistic fire training scenarios possible allowing trainees to experience the full impact of an emergency situation. Every critical environmental condition that a first responder may face during an emergency can be simulated, including darkness, smoke, sound, flames and heat – depending on the scenario desired. As a result, trainees come to fully experience the challenging physical and psychological effects both on themselves and on others participating in the exercise. Wherever possible, technical instruments and services such as propane and electrical supplies, ventilation systems, and pilot burners are “hidden” from view using special design elements and technologies.

Integrated focus on safety and performance

BullEx training systems are designed, built and installed to ensure that all safety controls are integrated directly into the operational device. Our technicians calibrate the safety settings for each module to maximize safety and ensure all training situations are of a consistent and high quality. BullEx systems are CSA and UL/ULC approved. BullEx’s in-house technical support team is completely familiar with all the details of your system and is on-call to provide the maintenance and service your training requires.

Effective training

Most importantly, the training system you acquire needs to be designed to effectively teach the lessons important for your actual risk and response situation. The training simulator must be a tool that addresses your training needs, and serves as a way to support the educational program of your instructors. All of our full-intensity training equipment is operated using the universal Pilot Module, meaning that you can easily customize and add to your selection of training props without excessive costs. BullEx is focused on designing systems that help teach the critical fire and safety skills needed to address your highest risk elements.

Experience

Bullex is a market leader in the field of fire and safety training equipment. Headquartered in New York, with offices in nine countries worldwide, Bullex serves a global customer base with its best-of-class training technologies. Our fire training systems have become the industry standard and have been used by thousands of organizations to train millions of people.

It's important to note that all Bullex props are covered by a **ten year construction warranty**. In addition, the pilot box, control console and all associated components are covered by a one year comprehensive warranty.

Bullex products have received numerous industry recognitions and awards, including (among others):

- Manufacturing Leadership Awards – New Product Leadership - 2015
- Prestigious Build Award for Excellence in Design and Construction – 2014
- Occupational Safety and Health Magazine – New Product of the Year – 2009
- Australia Fire Awareness Award – 2008
- National Registry of Environmental Professional – Environmental Training Award 2007

Bullex clients include every branch of the US armed forces, the US Department of Homeland Security, NASA, and thousands of other fire departments, government offices, and corporate clients.

Bullex is proud to provide the following offer. The specifications and the corresponding Bullex offer are summarized below.

Item #1: Bullex Hoseline Training System**\$18,995**

The Bullex Hoseline Training System includes the following features:

Fire Tray and Pilot Control Box

- Removable tray can be positioned independently to simulate a fuel spill or can be used in conjunction with several other Bullex training props
- Engineered for use with hand lines, CO2, and water extinguishers up to 150 lb.
- Liquid propane fueled, industrial grade fire fighter training unit
- Stainless steel 4' x 6' fire tray
- **CSA listed and approved stainless steel** continuous burn forced air pilot control box with four (4) burn zones for realistic fire simulation
- Removable pilot box can also be used with other Bullex props or fire trays



Mobile Control Console

- **UL Approved Control Console** interfaces between props and upstream propane and power supply. Houses core propane and power components, control components, optional wireless and sound effect components (if selected), and **built in E-stop button**.
- Includes 50 foot propane hose with **self-sealing quick disconnect fittings**, specifically designed to prevent gas leaks up to 250psi in high-pressure propane delivery situations. Hose and fittings constructed to withstand environment elements and heat from normal operation.
- **NEMA 4X** rated to resist corrosion
- Wired remote (unless upgraded to wireless) to independently start and stop multiple burn zones, with deadman button
- Includes power cable to connect to customers power supply



Item #2: Stove Fire Training Prop

\$11,995

Note: requires purchase of item #1 above

The BullEx Stove Fire Training Prop is a liquid propane fueled, live fire training prop used in conjunction with BullEx pilot module.

The Stove Fire Training Prop simulates a standard four burner stove fire. Built-in burners enable this prop to work directly with the Pilot and Burner Control Module. The main burner generates high intensity flames and the stove-top burner, with a functional shut-off valve, enables firefighters to advance hose lines and secure the gas supply.



Item #3: Propane Cylinder Fire Training Prop **\$2,995**

Note: requires purchase of item #1 above

The Propane Cylinder Fire Training Prop simulates a large-scale propane cylinder fire. Utilizing two (2) mock propane tanks and working in conjunction with the multiple burn-zones on the Hoseline training system, this prop can create propane fire scenarios from leaks under the tanks to fully involved fires with extension to valves on top of the tanks. Creates a realistic Hazardous Material training scenario. All steel construction. Includes 10-year construction warranty.

**Installation, Set-up and Training****Price: \$2,832**

Installation and calibration. Includes:

- Delivery to site
- Set-up and test operation of all props
- 4 hour train the trainer session for up to 10 people
- User manual
- Toll-Free technical support
- One-year comprehensive warranty on all materials and parts
- Ten-year construction warranty on the steel props
- Site work not included. It is the responsibility of the customer to provide propane and electricity to the console.

Contact

Thank you for considering BullEx as a trusted source for your fire training. It has been an honor for us to provide you with this budgetary proposal.

Please do not hesitate to contact us should you require any more information or have any questions about the proposal provided or our company.

Kathy Plant
Regional Sales Manager

20 Corporate Circle
Albany, NY 12203
Tel: 518.689.2023
Fax: 518.689.2034
www.bullex.com





SMOKE AND FLAMES WHERE LIVE FIRE ISN'T POSSIBLE

The Attack Digital Fire Training System combines digital flames, sound and smoke to create a range of fire conditions that respond directly to hose line application. Train with a seat of fire in acquired structures, training towers or any other location where live fire isn't possible or practical.

The Attack was developed in conjunction with instructors across the country who had two problems to solve.

First was the need to create the seat of fire in acquired structures and old burn buildings where live-fire wasn't an option.

The second was to have a good way to create realistic fire conditions for drills such as Vent Enter Search or RIT Operations, where the presence of fire is an important element, but fire suppression isn't the primary objective.

The Attack was developed specifically to meet these needs, and instructor feedback was instrumental in the system's design.

The Attack is tough enough to handle any hose line in your training arsenal. The Attack's digital flames respond to your hose line and diminish in response to proper hose line management, providing realistic firefighter training. Instructors can run repeatable and variable evolutions with push-button start and stop. With the Attack your training is done when each firefighter has mastered the skill, not when the fire is out of fuel.

[ATTACK™

DIGITAL FIRE TRAINING SYSTEM

CALL 1-888-4BULLEX OR VISIT OUR
WEBSITE AT WWW.BULLEX.COM

20 Corporate Circle • Albany, NY 12203
Phone 1-888-4BULLEX • 518-689-2023 | Fax 518-689-2034 | WWW.BULLEX.COM

©Bullex, Inc. All rights reserved.



① Use anything in your firefighting arsenal to attack the digital flames ② Refillable tank holds 400 lbs. of water to keep the panel stable ③ Waterproof Industrial Remote

HOW IT WORKS

SETUP The portable panel includes a weighted base with a refillable tank that holds 400 lbs. of water to keep the panel stable and upright during your most intense training scenarios. The panel is outfitted with a carrying strap for portability or can be wall-mounted in your facility.

REALISTIC FIRE GROWTH Fire growth and smoke conditions are based on fire research data provided by nationally recognized labs. Smoke output is tied to the size of the fire and the time since ignition. Once the fire is started it will grow and extend to additional panels while producing realistic volumes of smoke.

HOSE LINE DETECTION The watertight panel's integrated thermal sensors detect water application and the fire and smoke respond automatically. When water is applied directly to the seat of fire, Steam Conversion Technology™ recreates the low visibility conditions present when water is first applied to an actual fire.

REMOTE CONTROL The system includes a wireless remote that is used to start and stop evolutions with the push of a button. Choose the class of fire and difficulty level, as well as audio and smoke bursts. The waterproof Industrial

Remote is designed for use with gloved hands and can be clipped to turnout gear or clothing for easy access.

FIRE EXTENSION The Attack can include a single fire panel or multiple panels that connect wirelessly to create fire extension scenarios. Create scenarios where fire has extended into adjacent rooms or to the floor above. Long-range wireless connectivity means you can create scenarios such as balloon-frame building fires where basement fires extend first into the attic. Connect an unlimited number of panels together and customize the fire conditions to meet your specific objectives.

INTEGRATED SMOKE GENERATION The Attack is available with a BullEx SG4000 Smoke Generator capable of producing over 4,000 cubic feet of smoke per minute. The SG4000 is housed in a water and shock resistant case which also houses a GFCI power supply and a repeater station to extend the range of add-on panels and the Industrial Remote.

TRAINING OPPORTUNITIES

- Create basic or intense fire scenarios with extension where live fire isn't possible.

- Use the Attack to train on fundamentals so you can make the most of live-fire burns.
- Introduce new firefighters to fire and smoke conditions in a safe environment.
- Change the location and characteristics of the fire between evolutions and prevent training from becoming too predictable.
- Simulate fire conditions where getting water on the fire isn't the primary objective but the size and location of the fire is still an important element. Add more realism to drills such as Vent Enter Search, RIT Operations and Search and Rescue. Challenge trainees to maintain situational awareness, identify the location of the fire and if not extinguish, confine the fire while other critical operations take place.

SPECIFICATIONS

- Attack panel: 35 lbs.
- Weighted base: 33 lbs. empty. (400 lbs. when filled with water)
- 110/240 AC @50/60 Hz, 2 amps



ATTACK DIGITAL FIRE TRAINING SYSTEM [BASE PACKAGE

P/N: AT5001 • PRICE: \$9,985

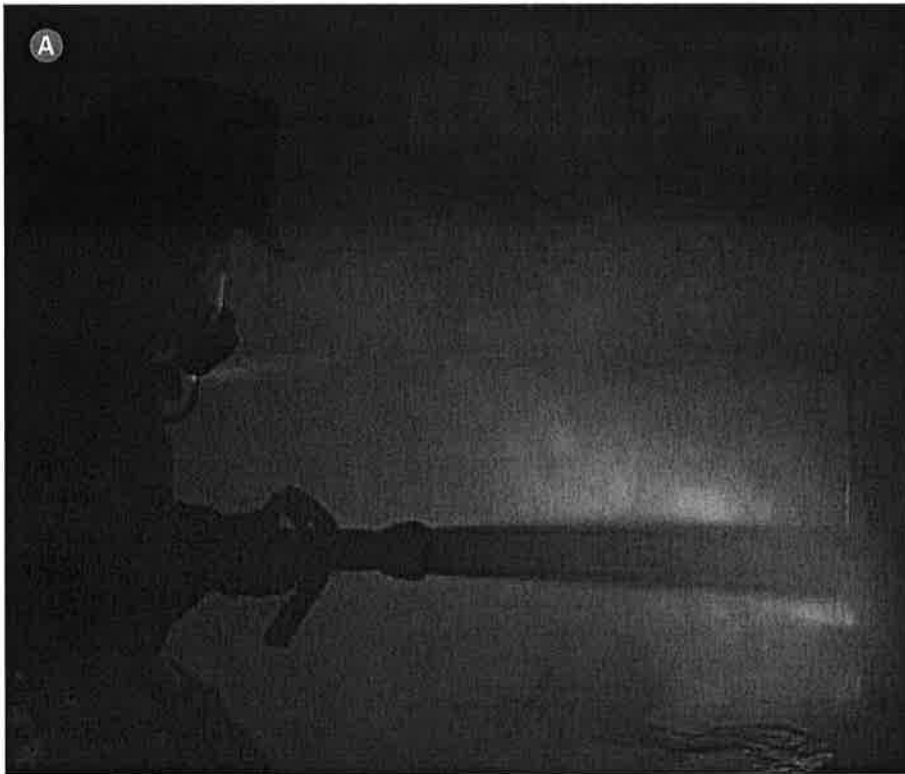

A ATTACK PANEL

This waterproof panel features thermal sensors that interact with a hose line and vary digital flames in response to realistically recreate the seat of a fire.

B WEIGHTED BASE WITH REFILLABLE WATER TANK

Fill the tank with up to 50 gallons of water to keep the panel upright and stable during intense training evolutions.

C SET-UP REMOTE

Use the infrared remote to start and stop evolutions as well as control the class of fire, difficulty, audio, and smoke bursts.

D POWER SUPPLY

100/240 AC at 50/60 HZ – 2 Amps.

- LIMITED ONE YEAR WARRANTY

[ACCESSORIES

E INDUSTRIAL REMOTE • P/N: AT5002IR • \$1,495

This waterproof remote communicates via Wi-Fi, is suited for intense training evolutions and can be operated with a gloved hand.

[SATELLITE FIRE PACKAGE

PRICE: \$7,895 • P/N: AT5001EF

The satellite fire panel connects wirelessly to the main Attack system to create fire extension scenarios. Create a larger seat of fire as well as scenarios where fire has extended into adjacent rooms or to the floor above.



Industrial Remote

- SECONDARY ATTACK PANEL
- WEIGHTED BASE WITH REFILLABLE WATER TANK



TAKE YOUR TRAINING TO THE NEXT LEVEL BY USING THE ATTACK™ IN CONJUNCTION WITH THE DIGITAL NOZZLE & WEIGHTED HOSE LINE

The Digital Nozzle and Weighted Hose Line allow you to conduct training evolutions where flowing water isn't possible. Conduct training in acquired structures, high-risk buildings, and anywhere else you'd like to simulate a fire attack without compromising the building.

Bullex Digital Nozzles are made using actual fire hose nozzles. The nozzles are equipped with infrared lasers, which interact with the Attack's self-generating digital flames. When in laser mode, the Attack's fire will only be knocked down if the trainee uses proper hose line technique.



CALL 1-888-4BULLEX OR VISIT OUR WEBSITE AT WWW.BULLEX.COM

DIGITAL NOZZLE



20 Corporate Circle • Albany, NY 12203

Phone 1-888-4BULLEX • 518-689-2023 | Fax 518-689-2034 | WWW.BULLEX.COM

©Bullex, Inc. All rights reserved.



① TFFT nozzle with realistic weighted hose ② Weighted hose line ③ Compressed air ④ Train where live fire is not possible ⑤ Teach fundamentals of hand line advancement

TRAINING OPPORTUNITIES

- Train in hospitals, schools, nursing homes, large manufacturing sites, or any other place where flowing water isn't permitted. Bring your firefighters to the very places they are tasked with protecting.
- Spend more time training and less time setting up, stretching and repacking hose.
- Flow water in acquired structures without the prep time that live burns require and without damaging the structure.
- Train on hose line advancement without taking an engine out of service.
- Prepare your firefighters for a wide range of emergency situations by exposing them to an infinite number of training sites. Challenge veteran firefighters who have your training tower memorized.
- Focus on fundamentals by teaching new trainees the fundamentals of hand line advancement technique before moving on to flowing water and live flames.

HOW IT WORKS

- Schrader valve fills with compressed air.
- To use, simply put the Attack panel in laser mode and turn on nozzle. The Attack will recognize the nozzle and react accordingly.
- Bail position (how open the nozzle is) determines how effective the digital laser is in putting out the fire. It also determines the volume of sound effects.

SPECIFICATIONS

- Uses a real TFFT 1 3/4 inch automatic nozzle — the most common nozzle. The nozzle is a real Task Force Tips automatic hand line nozzle, 1 3/4 inches. Other nozzles may be available upon request.
- Comes standard with 50 feet of real hose line. The hose line is weighted using compressed air to resemble the feel and behavior of a real charged hose line. Additional lengths available. Instructors can use a BullEx provided air compressor or one of their own.

FEATURES/BENEFITS

- **CONDUCT RAPID EVOLUTIONS** — No set up time, clean up time, don't have to flow water.
- **REALISTIC** — Real TFFT nozzle, weighted hose to resemble how a charged hose line feels.
- Like the Attack, this does not replace live-fire training or flowing water during training. This is to maximize your training time (spend time training and not setting up/breaking down), as well as reinforce technique before live-fire drills.
- **GREEN** — Flowing water during training will waste thousands of gallons of water.

ACCESSORIES

- High-rise transport pack available — transport case for nozzle and hose.



BullEx®

20 Corporate Circle • Albany, NY 12203

Phone 1-888-4BULLEX • 518-689-2023 | Fax 518-689-2034 | WWW.BULLEX.COM

©BullEx, Inc. All rights reserved.

[DIGITAL HOSE LINE NOZZLE

P/N: DHLN001 • PRICE: \$3,500



DIGITAL HOSE LINE NOZZLE

The Digital Hose Line Nozzle and Weighted Hose Line allow you to conduct training evolutions where flowing water isn't possible or necessary. Conduct training in acquired structures, high-risk buildings, and anywhere else you'd like to simulate a fire attack without compromising the building.

A DIGITAL HOSE LINE NOZZLE

BullEx Digital Hose Line Nozzles are made using actual TFT 1 $\frac{3}{4}$ inch automatic fire hose nozzles. The nozzles are equipped with infrared lasers, which interact with the Attack's self-generating digital flames. When in laser mode, the Attack's fire will only be knocked down if the trainee uses proper hose line technique. *Other nozzles may be available upon request.*

B WEIGHTED HOSE LINE

The Weighted Hose Line comes standard with 50 feet of real hose line and is weighted using compressed air to resemble the feel and behavior of a real charged hose line. Instructors can use a BullEx provided air compressor or one of their own. *Additional lengths available.*

- LIMITED ONE YEAR WARRANTY
- USER MANUAL

[ACCESSORIES

C DIGITAL NOZZLE TRANSPORT CASE

PRICE: \$295 • P/N: DHLN003
The Digital Nozzle Transport Case allows instructors to easily package and move the Digital Nozzle.

- ADDITIONAL 50 FT. WEIGHTED HOSE LINE
PRICE: \$695 • P/N: HL001





BullEx

20 Corporate Circle
® Albany, NY 12203
Ph. 518-689-2023
Fx. 518-689-2034

Quote

Quote Number:	85906
Date:	2/22/2016
Sales Person:	Kathy Plant
Valid Until:	3/22/2016
Terms:	Net 30

Bill To:	Ship To:	Contact:
Botetourt Fire-EMS 299 Dawnridge Ln. Troutville VA 24175 US	Botetourt Fire-EMS 299 Dawnridge Ln. Troutville VA 24175 US	Rob Johnson

Quantity	Part Number	Product	Unit Price	Ext. Price
1	ATS001	<p>Attack Digital Fire Training System: Base Package Turn any location into a burn room with BullEx's Attack Digital Fire Training System. Train in countless locations and situations to diversify training and ensure trainees are prepared to handle any real fire situation.</p> <p>The Base Package Includes:</p> <p>Attack Digital Fire Training Panel - waterproof panel featuring thermal sensors that interact with a hose line and vary digital flames in response to realistically recreate the seat of a fire.</p> <p>Weighted base with refillable water tank - fill the tank with up to 50 gallons of water to keep the panel upright and stable during intense training evolutions.</p> <p>Setup Remote - start and stop evolutions as well as control the class of fire, difficulty, audio and smoke bursts</p> <p>Power Supply</p> <p>Limited One Year Warranty</p>	\$9,985.00	\$9,985.00
1	DHLN001	<p>Digital Nozzle and Weighted Hose The Digital Hose Line and Nozzle allows firefighters to conduct hose line training without flowing water. Use in conjunction with the Attack Digital Fire Training System or on its own for realistic training. The system is constructed using an actual fire hose nozzle. The nozzle is equipped with infrared lasers, which interact with the Attack's self generating digital flames. This package includes the digital nozzle and 50 feet of weighted hose.</p>	\$3,500.00	\$3,500.00

1 ATC01SG

Waterproof Case - Smoke Generator
4000, Wi-Fi

\$1,895.00

\$1,895.00

This water and shock resistant case also
houses a GFCI power supply and a
repeater station to extend the range of
add-on panels and the Industrial Remote.

Grand Total		Subtotal:	\$15,380.00
Currency:	U.S. Dollar	Tax:	\$0.00
Tax Rate:	0.00%	Shipping & Handling:	\$483.41
Shipping Provider:		Total:	\$15,863.41

Warranty Terms: The warranty covers all part defects in material or workmanship for a period of one year from date of purchase unless otherwise specified. The customer will be responsible for return shipping to nearest BullEx facility or replacing parts supplied by BullEx. The warranty does not cover damage caused by accident, neglect, or misuse by the client or its agents, servants or employees. Standard warranty excludes batteries and battery packs which have a 90 day warranty.

Payment Terms: A penalty of 1.5% per month will be charged on any invoices not paid within 30 days. Customers are responsible for all duties, taxes, and customs charges. All payments must be in US Dollars. BullEx Inc. is not responsible for any currency exchange differences. All orders will be invoiced and/or charged on the day in which the order is shipped. Terms on BullEx, Inc. quotes supersede any terms and conditions on a customer purchase order. Customer agrees to fully comply with U.S. Export Administration Regulations and all other U.S. laws and regulations concerning exports and re-exports to foreign countries.

Botetourt County Proposal For 2016 Regional Fire Services Training Grant Program



FEB 25 2016



Commonwealth of Virginia
Department of Fire Programs

Administration
Virginia Fire Services Board
FY-2016 Regional Fire Services Training Facilities Grant Application

ATTACHMENT A

General Instructions & Notices

- Applicants are directed to "**Regional Fire Services Training Facilities Grant Program Policy**" as amended for the current funding year which is incorporated by reference to all applications and any subsequent awards. (Such practices document is inclusive of all *terms & conditions*.)
- The filing of an application does not bind the Board to award nor the Department to pay any such grant.
- Incomplete applications and those received after the deadline will not be considered.
(Deadline) → **March 1, 2016** postmarked
- Completed applications executed by the competent authority will only be accepted directly from jurisdictions not fire departments.
- Timeliness of filing and subsequent receipt by the Agency are solely the applicant's responsibility – all applications must be completed in ink and sent directly to: **VDFP Grants and Local Aid Manager,**
Address → 1005 Technology Park Drive, Glen Allen VA 23059-4500
- All decisions regarding grant awards made by the Board are final; applicants may appeal decisions in writing to the address provided above within 15 business days of the posting of awards.

A. Applicant Information

1. Title of Lead Jurisdiction Making Application (Check <input checked="" type="checkbox"/> only one, then make entry)	<input type="checkbox"/> County of	<input type="checkbox"/> City of	<input checked="" type="checkbox"/> Incorporated Town of Chilhowie
2. Employer Identification Number (EIN)	[REDACTED]		
3. Principal Point of Contact	(Include salutation, name & title.) Charles D. Haynes, Fire Chief		
4. Mailing Address (Include zip code) Identify COUNTY if appropriate	PO Box 5012 Chilhowie, Virginia 24319 Smyth		
5. Telephone Number	(276) 646-3131		
6. FAX Number	(276) 646-3615		
7. Internet e-mail address	cdhaynes2201@gmail.com		

B. Additional Parties

	Identify ALL jurisdictions (Not Fire Departments) participating in the proposed project. Attach additional sheets as may be required.
1. Formal Agreement Among Parties	<p>In accordance with Program Policy, multi-jurisdictional regional training partnerships must be documented (e.g. MOA, MOU, etc.) as required supporting documentation to the Application for consideration of Program funding.</p> <p>A copy of the Agreement has been attached to this application. <input checked="" type="checkbox"/> Yes <input type="checkbox"/> No</p> <p><i>If a copy of the Agreement has not been attached as required supporting documentation, this Application will be considered incomplete and funding will not be approved.</i></p>

FEB 25 2016



Commonwealth of Virginia
Department of Fire Programs

Virginia Fire Services Board
FY-2016 Regional Fire Services Training Facilities Grant Application

Administration

{ Reproduce and complete as many additional blocs as may be necessary for complete disclosure. }

2a. Complete <u>one each</u> for ALL other Parties of Interest	Number <input type="text" value="2"/> of a total of <input type="text" value="3"/> parties to proposed project (Count the LEAD Locality as #1, thereby start with #2.)									
2b. Title of Jurisdiction (Check <input checked="" type="checkbox"/> only one, then make entry)	<table border="1"> <tr> <td><input type="checkbox"/></td> <td>County of</td> <td></td> </tr> <tr> <td><input type="checkbox"/></td> <td>City of</td> <td></td> </tr> <tr> <td><input checked="" type="checkbox"/></td> <td>Incorporated Town of</td> <td>Marion</td> </tr> </table>	<input type="checkbox"/>	County of		<input type="checkbox"/>	City of		<input checked="" type="checkbox"/>	Incorporated Town of	Marion
<input type="checkbox"/>	County of									
<input type="checkbox"/>	City of									
<input checked="" type="checkbox"/>	Incorporated Town of	Marion								
2c. Employer Identification Number (EIN)	[REDACTED]									
2d. Principal Point of Contact (Include salutation, name & title.)	Richard Keesling, Chief of Operations									
2e. Mailing Address (Include zip code+4) Identify COUNTY if appropriate	231 West Main Street Marion, Virginia 24354									
2f. Telephone Number	() 276-783-0916									
2g. FAX Number	() 276-783-0966									
2h. Internet e-mail address	richardkeesling@comcast.net									

{ Reproduce and complete as many additional blocs as may be necessary for complete disclosure. }

2a. Complete <u>one each</u> for ALL other Parties of Interest	Number <input type="text" value="3"/> of a total of <input type="text" value="3"/> parties to proposed project (Count the LEAD Locality as #1, thereby start with #2.)									
2b. Title of Jurisdiction (Check <input checked="" type="checkbox"/> only one, then make entry)	<table border="1"> <tr> <td><input type="checkbox"/></td> <td>County of</td> <td></td> </tr> <tr> <td><input type="checkbox"/></td> <td>City of</td> <td></td> </tr> <tr> <td><input checked="" type="checkbox"/></td> <td>Incorporated Town of</td> <td>Adwolfe Volunteer Fire Department (Independent)</td> </tr> </table>	<input type="checkbox"/>	County of		<input type="checkbox"/>	City of		<input checked="" type="checkbox"/>	Incorporated Town of	Adwolfe Volunteer Fire Department (Independent)
<input type="checkbox"/>	County of									
<input type="checkbox"/>	City of									
<input checked="" type="checkbox"/>	Incorporated Town of	Adwolfe Volunteer Fire Department (Independent)								
2c. Employer Identification Number (EIN)	[REDACTED]									
2d. Principal Point of Contact (Include salutation, name & title.)	Steve Widener, Fire Chief									
2e. Mailing Address (Include zip code+4) Identify COUNTY if appropriate	104 Thomas Bridge Road, PO Box 1305 Marion, Virginia 24354									
2f. Telephone Number	() 276-783-6444									
2g. FAX Number	() 276-783-3602									
2h. Internet e-mail address	adwolfefire@yahoo.com									

{ Reproduce and complete as many additional blocs as may be necessary for complete disclosure. }

2a. Complete <u>one each</u> for ALL other Parties of Interest	Number <input type="text"/> of a total of <input type="text"/> parties to proposed project (Count the LEAD Locality as #1, thereby start with #2.)									
2b. Title of Jurisdiction (Check <input checked="" type="checkbox"/> only one, then make entry)	<table border="1"> <tr> <td><input type="checkbox"/></td> <td>County of</td> <td></td> </tr> <tr> <td><input type="checkbox"/></td> <td>City of</td> <td></td> </tr> <tr> <td><input type="checkbox"/></td> <td>Incorporated Town of</td> <td></td> </tr> </table>	<input type="checkbox"/>	County of		<input type="checkbox"/>	City of		<input type="checkbox"/>	Incorporated Town of	
<input type="checkbox"/>	County of									
<input type="checkbox"/>	City of									
<input type="checkbox"/>	Incorporated Town of									
2c. Employer Identification Number (EIN)	[REDACTED]									
2d. Principal Point of Contact (Include salutation, name & title.)	[REDACTED]									
2e. Mailing Address (Include zip code+4) Identify COUNTY if appropriate	[REDACTED]									
2f. Telephone Number	()									
2g. FAX Number	()									
2h. Internet e-mail address	[REDACTED]									



FEB 25 2016

Administration

Department of Fire Programs

C. Previous Applications/Awards

1.	Has the Applicant previously applied for a RFSTF Grant from the Board? - check <input checked="" type="checkbox"/> one	<input type="checkbox"/> No	<input checked="" type="checkbox"/> Yes
2.	Has the Applicant previously received a RFSTF Grant from the Board? - check <input checked="" type="checkbox"/> one	<input type="checkbox"/> No	<input checked="" type="checkbox"/> Yes

D. Project Title(s) and Description(s) *Enter a descriptive 'Title' and brief 'Description' for the lead training project and/or program proposed for funding from any Grant which may be awarded pursuant to this application.*

1	(Project Title) Propane Car Fire Prop	(Description) Propane fueled car fire training prop complete with the required accessories. (Only those accessories necessary to make a functional car fire training prop are requested).
Which statement best describes the above proposed project and/or program? check <input checked="" type="checkbox"/> one		<input checked="" type="checkbox"/> New <input type="checkbox"/> Change to existing <input type="checkbox"/> Continuing
Which statement best describes how many training programs may benefit from the proposal? check <input checked="" type="checkbox"/> one		<input checked="" type="checkbox"/> Multiple Programs <input type="checkbox"/> Single Program
Describe the impact on training if this Grant is not awarded, or check <input checked="" type="checkbox"/>		<input type="checkbox"/> No Significant Impact
This type of prop is not currently available at any of the training centers that serve the Washington, Smyth, Wythe or Grayson County fire departments. Current local burning regulations as well as safety issues prohibit us from using actual automobiles for live fire training.		
<input type="checkbox"/> ← Check <input checked="" type="checkbox"/> IF a Continuation D Sheet is used to account for more than one (1) project / program. IMPORTANT, if box above is checked and no continuation sheets are attached, the application will not be further considered.		

E. Project Goods & Services Requested *In the below table, itemize in priority order – starting with the most needed first, ALL items of "Goods" (e.g. equipment, hardware or other durable items) or categories of "Services" which are to be funded in whole or in part from any Grant which may be awarded pursuant to this application.*

Enter Project Title from [D] above	Check <input checked="" type="checkbox"/> One	Description	Total Cost	Less any Matching Funds	Grant Amount Requested
1	<input checked="" type="checkbox"/> Goods	Car fire prop with burn pan, burners, regulators, hoses, control box and power cables.	(a)	(b)	(a-b)
	<input type="checkbox"/> Services		\$ 46,100.00	\$ -	\$ 46,100.00
2	<input type="checkbox"/> Goods		(a)	(b)	(a-b)
	<input type="checkbox"/> Services		\$ -	\$ -	\$ -
3	<input type="checkbox"/> Goods		(a)	(b)	(a-b)
	<input type="checkbox"/> Services		\$ -	\$ -	\$ -
4	<input type="checkbox"/> Goods		(a)	(b)	(a-b)
	<input type="checkbox"/> Services		\$ -	\$ -	\$ -
5	<input type="checkbox"/> Goods		(a)	(b)	(a-b)
	<input type="checkbox"/> Services		\$ -	\$ -	\$ -

← Check IF a Continuation D Sheet is used to account for more than one (1) project / program. IMPORTANT, if box above is checked and no continuation sheets are attached, the application will not be further considered.

E	Enter here the lesser amount of: • Sum of all items (1 thru n) under "Grant Amount Requested" • OR \$50,000 (Grant maximum)	\$ 46,100.00
---	---	--------------

**TOWN OF CHILHOWIE
FIRE & EMS DEPARTMENT**



**REGIONAL GRANT PROPOSAL
VEHICLE FIRE PROP**

Kidde Fire Trainers, LLC
17 Philips Parkway
Montvale, NJ 07645-1810 USA
Tel +1 201.300.8100
Fax +1 201.300.8101
www.kiddefit.com



Q9746-JE-27Jan2016

Town of Chilhowie Fire and EMS
223 E. Lee Highway
Chilhowie, VA 24319

Attention: Chief David Haynes

Subject: Budgetary Proposal for a Kidde FIRETRAINER® Systems

Dear Chief Haynes,

Kidde Fire Trainers, LLC is pleased to provide this budgetary price proposal for your consideration. We have included various options, the pilot box, hoses, and controls are required for all items. All of the controls, props, and systems are NRTL, 3rd party certified, by ETL.

We welcome the opportunity to discuss this proposal and can revise the options to your needs. The pricing is structured for a standalone control system, typically with the pan fire, then to add options for additional props. The car prop does not require the use of a pan.

Please do not hesitate to contact me at (410) 256-3126 with any questions. We look forward to fulfilling your fire training needs.

Sincerely,

James R. Eicholtz

James R. Eicholtz
Regional Sales Representative
KIDDE FIRE TRAINERS, INC.

This document and subsequent pages include information that is proprietary to Kidde Fire Trainers, LLC and shall not be disclosed outside of the addressee's organization and shall not be duplicated, used or disclosed - in whole or in part - for any reason other than to evaluate our offering.

Budgetary Price Proposal

Item	Description	Price
1	<p>O-100 Controls and Pilot Box</p> <ul style="list-style-type: none"> ▪ Independent pilot burner ▪ Two-stage main flame ▪ Handheld operator control pendant with 30' cable ▪ 50-ft AC power cable ▪ All required propane hoses and regulators ▪ Aluminum hose guards <p><u>Logistics & Support</u></p> <ul style="list-style-type: none"> ▪ Operation and maintenance manual ▪ One year standard warranty ▪ 24/7 technical phone support 	\$ 12,950
1A	<p>O-100 Burn Pan (24 sq. ft.)</p> <ul style="list-style-type: none"> ▪ Stainless steel ▪ water bath burn platform ▪ 4' x 6' burn area ▪ 60,000.000 btu/hr - high fire output capacity 	\$ 5,250
Options		
2	O-100 Car mock-up (to be used with existing pilot box & accessories from O-100 Pan - Item #1)	\$27,900
3	O-100 Propane Tank mock-up (to be used with existing pilot box & accessories from O-100 Pan - Item #1)	\$6,900
4	O-100 Dual Split Pipe Flange Prop (to be used with existing pilot box & accessories from O-100 Pan - Item #1)	\$ 9,800
5	O-100 Propane Cylinder Prop – (3 x 100 lbs.) (to be used with existing pilot box & accessories from O-100 Pan - Item #1)	\$3,950
6	O-100 Christmas Tree Prop (to be used with existing pilot box & accessories from O-100 Pan - Item #1 and Item#1A)	\$ 4,500
7	Motor Generator Prop (to be used with existing pilot box & accessories from O-100 Pan – Item #1 and Item #1A)	\$ 4,150
8	Electrical Transformer - O-100 (to be used with existing pilot box & accessories from O-100 Pan - Item #1 and Item #1A)	\$ 4,150

Price Validity

Prices valid until 31 July 2016.
 Kidde's Standard Terms & Conditions apply to any resulting order.

Preferred Payment Terms

Kidde will invoice at the following milestones. Net 30 days.

- 30% invoiced upon order
- 70% invoiced upon shipment of the trainer to site

Kidde welcomes the opportunity to negotiate payment terms.

Delivery

180 days after acceptance of an order.

Exclusions

Shipping & handling

Prices exclude the cost of a payment and performance bond, permits, and any local and state sales taxes that may be applicable.



General Instructions & Notices

- Applicants are directed to "**Regional Fire Services Training Facilities Grant Program Policy**" as amended for the current funding year which is incorporated by reference to all applications and any subsequent awards. (Such practices document is inclusive of all *terms & conditions*.)
- The filing of an application does not bind the Board to award nor the Department to pay any such grant.
- Incomplete applications and those received after the deadline will not be considered.
(Deadline) → **March 1, 2016** postmarked
- Completed applications executed by the competent authority will only be accepted directly from jurisdictions not fire departments.
- Timeliness of filing and subsequent receipt by the Agency are solely the applicant's responsibility – all applications must be completed in ink and sent directly to: **VDFP Grants and Local Aid Manager**,
Address → **1005 Technology Park Drive, Glen Allen VA 23059-4500**
- All decisions regarding grant awards made by the Board are final; applicants may appeal decisions in writing to the address provided above within 15 business days of the posting of awards.

A. Applicant Information

1. Title of Lead Jurisdiction Making Application (Check <input checked="" type="checkbox"/> only one, then make entry)	<input type="checkbox"/> County of	<input type="checkbox"/> City of	<input checked="" type="checkbox"/> Incorporated Town of Farmville
2. Employer Identification Number (EIN)	[REDACTED]		
3. Principal Point of Contact	(Include salutation, name & title.) Gerald J. Spates, Town Manager		
4. Mailing Address (Include zip code) Identify COUNTY if appropriate	116 North Main Street PO Drawer 368 Farmville, Virginia 23901		
5. Telephone Number	(434)	392-5686	
6. FAX Number	(434)	392-3160	
7. Internet e-mail address	gspates@farmvilleva.com		

B. Additional Parties

	Identify ALL jurisdictions (Not Fire Departments) participating in the proposed project. Attach additional sheets as may be required.
1. Formal Agreement Among Parties	<p>In accordance with Program Policy, multi-jurisdictional regional training partnerships must be documented (e.g. MOA, MOU, etc.) as required supporting documentation to the Application for consideration of Program funding.</p> <p>A copy of the Agreement has been attached to this application. <input checked="" type="checkbox"/> Yes <input type="checkbox"/> No</p> <p><i>If a copy of the Agreement has not been attached as required supporting documentation, this Application will be considered incomplete and funding will not be approved.</i></p>

Department of Fire Programs
FEB 25 2016
Administration



{ Reproduce and complete as many additional blocs as may be necessary for complete disclosure. }

2a. Complete <u>one each</u> for ALL other Parties of Interest	Number 2 of a total of 4 parties to proposed project <small>(Count the LEAD Locality as #1, thereby start with #2.)</small>
2b. Title of Jurisdiction <small>(Check <input checked="" type="checkbox"/> only one, then make entry)</small>	<input checked="" type="checkbox"/> County of Prince Edward <input type="checkbox"/> City of _____ <input type="checkbox"/> Incorporated Town of _____
2c. Employer Identification Number (EIN)	[REDACTED]
2d. Principal Point of Contact <small>(Include salutation, name & title.)</small>	Mr. Wade Bartlett, County Administrator
2e. Mailing Address <small>(Include zip code+4)</small> <small>Identify COUNTY if appropriate -</small>	P.O. Box 382 Farmville, Virginia 23901 Prince Edward County
2f. Telephone Number	() 434-392-8837
2g. FAX Number	() 434-392-6683
2h. Internet e-mail address	wbartlett@co.prince-edward.va.us

{ Reproduce and complete as many additional blocs as may be necessary for complete disclosure. }

2a. Complete <u>one each</u> for ALL other Parties of Interest	Number 3 of a total of 4 parties to proposed project <small>(Count the LEAD Locality as #1, thereby start with #2.)</small>
2b. Title of Jurisdiction <small>(Check <input checked="" type="checkbox"/> only one, then make entry)</small>	<input checked="" type="checkbox"/> County of Charlotte <input type="checkbox"/> City of _____ <input type="checkbox"/> Incorporated Town of _____
2c. Employer Identification Number (EIN)	[REDACTED]
2d. Principal Point of Contact <small>(Include salutation, name & title.)</small>	Mr. R. B. Clark, Jr., County Administrator
2e. Mailing Address <small>(Include zip code+4)</small> <small>Identify COUNTY if appropriate -</small>	P.O. Box 608 250 LeGrande Ave., Suite A Charlotte Court House, Virginia 23923 (Charlotte County)
2f. Telephone Number	() 434-542-5117
2g. FAX Number	() 434-542-5248
2h. Internet e-mail address	rclark@charlotteva.com

{ Reproduce and complete as many additional blocs as may be necessary for complete disclosure. }

2a. Complete <u>one each</u> for ALL other Parties of Interest	Number 4 of a total of 4 parties to proposed project <small>(Count the LEAD Locality as #1, thereby start with #2.)</small>
2b. Title of Jurisdiction <small>(Check <input checked="" type="checkbox"/> only one, then make entry)</small>	<input checked="" type="checkbox"/> County of Cumberland <input type="checkbox"/> City of _____ <input type="checkbox"/> Incorporated Town of _____
2c. Employer Identification Number (EIN)	[REDACTED]
2d. Principal Point of Contact <small>(Include salutation, name & title.)</small>	Ms. Vivian Giles, County Administrator
2e. Mailing Address <small>(Include zip code+4)</small> <small>Identify COUNTY if appropriate -</small>	P.O. Box 110 1 Courthouse Circle Cumberland, Virginia 23040
2f. Telephone Number	() 804-492-3625
2g. FAX Number	() 804-492-9224
2h. Internet e-mail address	vgiles@cumberlandcounty.virginia.gov



Department of Fire Programs
FEB 25 2016
Administration

C. Previous Applications/Awards

1.	Has the Applicant previously applied for a RFSTF Grant from the Board? - <i>check <input checked="" type="checkbox"/> one</i>	<input checked="" type="checkbox"/> No	<input type="checkbox"/> Yes
2.	Has the Applicant previously received a RFSTF Grant from the Board? - <i>check <input checked="" type="checkbox"/> one</i>	<input checked="" type="checkbox"/> No	<input type="checkbox"/> Yes

D. Project Title(s) and Description(s)

Enter a descriptive 'Title' and brief 'Description' for the lead training project ^{and/or} program proposed for funding from any Grant which may be awarded pursuant to this application.

1	(Project Title) Vehicle Fire Prop and Trailer	(Description) Purchase a propane-fed mobile vehicle fire prop that will be based at the Town of Farmville's Regional Fire Training Facility. This prop will be used for live fire training for 17 volunteer fire departments in 3 counties.
Which statement best describes the above proposed project and/or program? <i>check <input checked="" type="checkbox"/> one</i>		
<input checked="" type="checkbox"/> New <input type="checkbox"/> Change to existing <input type="checkbox"/> Continuing		
Which statement best describes how many training programs may benefit from the proposal? <i>check <input checked="" type="checkbox"/> one</i>		
<input checked="" type="checkbox"/> Multiple Programs <input type="checkbox"/> Single Program		
Describe the impact on training if this Grant is not awarded, or check <input checked="" type="checkbox"/> No Significant Impact		
This grant will allow the Farmville Fire Department to have a mobile reusable source for vehicle fire training. Without this grant, Farmville does not have adequate budgeted funds to acquire this training vehicle. This training vehicle will be used by 17 volunteer fire departments in 3 counties. Junk cars for this training are hard to find and can be potentially dangerous and negatively affect air quality.		
<input type="checkbox"/> ← Check <input checked="" type="checkbox"/> IF a Continuation D Sheet is used to account for more than one (1) project / program.		
IMPORTANT, if box above is checked and no continuation sheets are attached, the application will not be further considered.		

E. Project Goods & Services Requested

In the below table, itemize in priority order – starting with the most needed first, **ALL** items of "Goods" (e.g. equipment, hardware or other durable items) or categories of "Services" which are to be funded in whole or in part from any Grant which may be awarded pursuant to this application.

Enter Project Title from [D] above	Check <input checked="" type="checkbox"/> One	Description	Total Cost	Less any Matching Funds	Grant Amount Requested
1	<input checked="" type="checkbox"/> Goods <input type="checkbox"/> Services	Purchase of a mobile Vehicle Fire Training Prop to include delivery, set-up and training, wireless remote control, 10-year warranty, 4 burn zones, pry-able and roll-able hood, and integrated cooling system.	(a) \$ 46,816.00	(b) \$ -	(a-b) \$ 46,816.00
2	<input checked="" type="checkbox"/> Goods <input type="checkbox"/> Services	18' trailer used to store and safely transport car fire prop to multiple jurisdictions.	(a) \$ 2,295.00	(b) \$ -	(a-b) \$ 2,295.00
3	<input type="checkbox"/> Goods <input type="checkbox"/> Services		(a) \$ -	(b) \$ -	(a-b) \$ -
4	<input type="checkbox"/> Goods <input type="checkbox"/> Services		(a) \$ -	(b) \$ -	(a-b) \$ -
5	<input type="checkbox"/> Goods <input type="checkbox"/> Services		(a) \$ -	(b) \$ -	(a-b) \$ -

← **Check IF a Continuation D Sheet is used to account for more than one (1) project / program.**
IMPORTANT, if box above is checked and no continuation sheets are attached, the application will not be further considered.

E	Enter here the lesser amount of: • Sum of all items (1 thru n) under "Grant Amount Requested" • OR \$50,000 (<i>Grant maximum</i>)	\$ 49,111.00
----------	--	---------------------



Department of Fire Programs

FEB 25 2016

Administration

F. Matching/Cost Share				
1	Which statement best describes the matching funds contributions? <i>check <input checked="" type="checkbox"/> one</i>	<input type="checkbox"/> 50% or More	<input type="checkbox"/> Less than 50%	<input checked="" type="checkbox"/> None

G. ATL Funding				
1	What is the amount of the Applicant's FY-2015 Aid to Localities (ATL) allocation from the Fire Programs Fund? <i>check <input checked="" type="checkbox"/> one and complete as necessary</i>	<input type="checkbox"/> \$10,000 or \$20,000 exactly	<input checked="" type="checkbox"/> Other - Enter amount here	<input type="text" value="\$26,030"/>
2	Did the Applicant have cash carry forward from FY-2015 into FY-2016 from previous years' Aid to Localities (ATL) allocations? <i>check <input checked="" type="checkbox"/> one and complete as necessary</i>	<input type="checkbox"/> Yes	<input checked="" type="checkbox"/> No	If "Yes", amount of FY-2015 ATL carry forward: <input type="text"/>

Remarks	Make entries or check <input checked="" type="checkbox"/>	<input checked="" type="checkbox"/> None	Important: If the sum (1 to n) of individual "Grant Amount. Requested" in E above exceeded \$50,000, an explanation must be entered here as to how the shortfall would otherwise be made up.

EFT (EDI)
Grant awards are paid as an Electronic Funds Transfer / EDI to the current account-of-record for the jurisdiction's annual allocation of Aid to Localities (ATL) from the Fire Programs Fund.

Certification:
To be completed by either:

- County Administrator –or- Executive, City Manager, Town Mayor –or- Administrator; Deputy, or...
- Other duly authorized official whereby the application is accompanied by a copy of an 'Ordinance' or other such formal instrument clearly granting that party such authority.

This grant application is entered on behalf of the APPLICANT jurisdiction identified above with the knowledge and belief that all representations herein made are true and correct; with the understanding that all grant terms & conditions in-force as of the date of such application are hereby included by reference; with the further understanding that if an award is granted pursuant to this application that the recipient is bound by those same terms & conditions.

	2/19/16
Signature	Date
Gerald J. Spates	Farmville Town Manager
Printed Name	Title

(All applications must be notarized to be considered – incomplete forms shall be returned.)

State of Virginia }
City / County of Prince Edward }

On this 19th day of February (month) in 2016 (year), before me, the undersigned a Notary Public for the Commonwealth of Virginia, personally appeared Gerald J. Spates to me known (or to me proved) to be the identical person named herein and having in my presence executed the above, and acknowledged that he executed same as his voluntary act and deed.

My Commission expires: 9/30/2019 Date

Notary Public

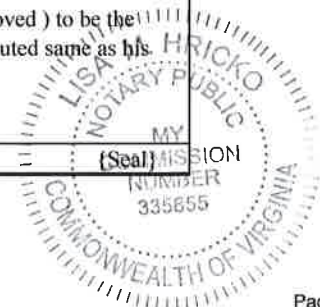

ATTACHMENT
Memorandum Of Understanding (MOU)
From The Following Entities:

Prince Edward County
Darlington Heights Volunteer Fire Department
Hampden-Sydney Volunteer Fire Department
Meherrin Volunteer Fire Department
Pamplin Volunteer Fire Department
Prospect Volunteer Fire Department
Rice Volunteer Fire Department

Charlotte County
Bacon Volunteer Fire Department
Charlotte Court House Volunteer Fire Department
Cullen Volunteer Fire Department
Drakes Branch Volunteer Fire Department
Keysville Volunteer Fire Department
Phenix Volunteer Fire Department
Red House Volunteer Fire Department

Cumberland County
Cartersville Volunteer Fire Department
Cumberland Volunteer Fire Department
Randolph Volunteer Fire Department



Memorandum of Understanding
Multi-Jurisdictional Regional Fire Training Partnership
For Use of a Vehicle Fire Training Prop
Between
The Town of Farmville, Farmville Volunteer Fire Department
And
Prince Edward County



Purpose:

The Town of Farmville and the Farmville Fire Department recognizes the value of a regional partnership in fire service related training as well as Virginia Department of Fire Programs Certification Training. The purpose of this Memorandum of Understanding (MOU) is to provide an outline for the use of a vehicle fire training prop used by multiple jurisdictions to enhance fire training in the Division 3 Area.

Scope:

This MOU provides that the Town of Farmville will maintain the fire training prop and provide the participating fire departments with access to the training prop as needed, unless otherwise in use. The participating fire department shall be responsible for the replacement of fuel for the training prop. Also the liability shall be assumed by the participating fire department utilizing the training prop. While the lead fire department participants (Town of Farmville, Charlotte, Cumberland and Prince Edward Counties) shall be the primary users, the prop will be made available upon request and at the discretion of the Town of Farmville. Agencies shall operate under the same guidelines as provided and a qualified operator shall be onsite to oversee the training operation.

Term:

The period of the MOU shall be based on the fiscal year, beginning on July 1st of the current year and end on June 30th of the following year. The MOU shall be evaluated each year and any changes shall be incorporated into the next year's MOU. The agreement shall exist for the serviceable life of the prop.

Monetary Terms:

This MOU further outlines that each use of the training prop shall be documented and the amount of propane used shall be replenished after each use to ensure a state of readiness. The Town of Farmville reserves the right to request, but shall not require, funding from the participating localities should operating and maintenance expenditures become excessive.



Farmville Town Manager

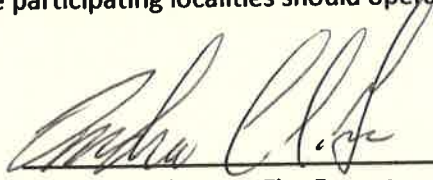

Farmville Volunteer Fire Department, Chief



Prince Edward County Administrator

2/5/15

DATE



Memorandum of Understanding
Multi-Jurisdictional Regional Fire Training Partnership
For Use of a Vehicle Fire Training Prop
Between
The Town of Farmville, Farmville Volunteer Fire Department
And
Darlington Heights Volunteer Fire Department



Purpose:

The Town of Farmville and the Farmville Fire Department recognizes the value of a regional partnership in fire service related training as well as Virginia Department of Fire Programs Certification Training. The purpose of this Memorandum of Understanding (MOU) is to provide an outline for the use of a vehicle fire training prop used by multiple jurisdictions to enhance fire training in the Division 3 Area.

Scope:

This MOU provides that the Town of Farmville will maintain the fire training prop and provide the participating fire departments with access to the training prop as needed, unless otherwise in use. The participating fire department shall be responsible for the replacement of fuel for the training prop. Also the liability shall be assumed by the participating fire department utilizing the training prop. While the lead fire department participants (Town of Farmville, Charlotte, Cumberland and Prince Edward Counties) shall be the primary users, the prop will be made available upon request and at the discretion of the Town of Farmville. Agencies shall operate under the same guidelines as provided and a qualified operator shall be onsite to oversee the training operation.

Term:

The period of the MOU shall be based on the fiscal year, beginning on July 1st of the current year and end on June 30th of the following year. The MOU shall be evaluated each year and any changes shall be incorporated into the next year's MOU. The agreement shall exist for the serviceable life of the prop.

Monetary Terms:

This MOU further outlines that each use of the training prop shall be documented and the amount of propane used shall be replenished after each use to ensure a state of readiness. The Town of Farmville reserves the right to request, but shall not require, funding from the participating localities should operating and maintenance expenditures become excessive.

Farmville Town Manager

Farmville Volunteer Fire Department, Chief

Darlington Heights Volunteer Fire Department, Chief

DATE

2/7/14



Memorandum of Understanding
 Multi-Jurisdictional Regional Fire Training Partnership
 For Use of a Vehicle Fire Training Prop
 Between
 The Town of Farmville, Farmville Volunteer Fire Department
 And
 Hampden-Sydney Volunteer Fire Department



Purpose:

The Town of Farmville and the Farmville Fire Department recognizes the value of a regional partnership in fire service related training as well as Virginia Department of Fire Programs Certification Training. The purpose of this Memorandum of Understanding (MOU) is to provide an outline for the use of a vehicle fire training prop used by multiple jurisdictions to enhance fire training in the Division 3 Area.

Scope:

This MOU provides that the Town of Farmville will maintain the fire training prop and provide the participating fire departments with access to the training prop as needed, unless otherwise in use. The participating fire department shall be responsible for the replacement of fuel for the training prop. Also the liability shall be assumed by the participating fire department utilizing the training prop. While the lead fire department participants (Town of Farmville, Charlotte, Cumberland and Prince Edward Counties) shall be the primary users, the prop will be made available upon request and at the discretion of the Town of Farmville. Agencies shall operate under the same guidelines as provided and a qualified operator shall be onsite to oversee the training operation.

Term:

The period of the MOU shall be based on the fiscal year, beginning on July 1st of the current year and end on June 30th of the following year. The MOU shall be evaluated each year and any changes shall be incorporated into the next year's MOU. The agreement shall exist for the serviceable life of the prop.

Monetary Terms:

This MOU further outlines that each use of the training prop shall be documented and the amount of propane used shall be replenished after each use to ensure a state of readiness. The Town of Farmville reserves the right to request, but shall not require, funding from the participating localities should operating and maintenance expenditures become excessive.

Farmville Town Manager

Farmville Volunteer Fire Department, Chief

Hampden-Sydney Volunteer Fire Department, Chief

DATE

2/2/2016



Memorandum of Understanding

Multi-Jurisdictional Regional Fire Training Partnership

For Use of a Vehicle Fire Training Prop

Between

The Town of Farmville, Farmville Volunteer Fire Department

And

Meherrin Volunteer Fire Department



Purpose:

The Town of Farmville and the Farmville Fire Department recognizes the value of a regional partnership in fire service related training as well as Virginia Department of Fire Programs Certification Training. The purpose of this Memorandum of Understanding (MOU) is to provide an outline for the use of a vehicle fire training prop used by multiple jurisdictions to enhance fire training in the Division 3 Area.

Scope:

This MOU provides that the Town of Farmville will maintain the fire training prop and provide the participating fire departments with access to the training prop as needed, unless otherwise in use. The participating fire department shall be responsible for the replacement of fuel for the training prop. Also the liability shall be assumed by the participating fire department utilizing the training prop. While the lead fire department participants (Town of Farmville, Charlotte, Cumberland and Prince Edward Counties) shall be the primary users, the prop will be made available upon request and at the discretion of the Town of Farmville. Agencies shall operate under the same guidelines as provided and a qualified operator shall be onsite to oversee the training operation.

Term:

The period of the MOU shall be based on the fiscal year, beginning on July 1st of the current year and end on June 30th of the following year. The MOU shall be evaluated each year and any changes shall be incorporated into the next year's MOU. The agreement shall exist for the serviceable life of the prop.

Monetary Terms:

This MOU further outlines that each use of the training prop shall be documented and the amount of propane used shall be replenished after each use to ensure a state of readiness. The Town of Farmville reserves the right to request, but shall not require, funding from the participating localities should operating and maintenance expenditures become excessive.

Farmville Town Manager

Farmville Volunteer Fire Department, Chief

Meherrin Volunteer Fire Department, Chief

02-04-16

DATE



Memorandum of Understanding
 Multi-Jurisdictional Regional Fire Training Partnership
 For Use of a Vehicle Fire Training Prop
 Between
 The Town of Farmville, Farmville Volunteer Fire Department
 And
 Pamplin Volunteer Fire Department



Purpose:

The Town of Farmville and the Farmville Fire Department recognizes the value of a regional partnership in fire service related training as well as Virginia Department of Fire Programs Certification Training. The purpose of this Memorandum of Understanding (MOU) is to provide an outline for the use of a vehicle fire training prop used by multiple jurisdictions to enhance fire training in the Division 3 Area.

Scope:

This MOU provides that the Town of Farmville will maintain the fire training prop and provide the participating fire departments with access to the training prop as needed, unless otherwise in use. The participating fire department shall be responsible for the replacement of fuel for the training prop. Also the liability shall be assumed by the participating fire department utilizing the training prop. While the lead fire department participants (Town of Farmville, Charlotte, Cumberland and Prince Edward Counties) shall be the primary users, the prop will be made available upon request and at the discretion of the Town of Farmville. Agencies shall operate under the same guidelines as provided and a qualified operator shall be onsite to oversee the training operation.

Term:

The period of the MOU shall be based on the fiscal year, beginning on July 1st of the current year and end on June 30th of the following year. The MOU shall be evaluated each year and any changes shall be incorporated into the next year's MOU. The agreement shall exist for the serviceable life of the prop.

Monetary Terms:

This MOU further outlines that each use of the training prop shall be documented and the amount of propane used shall be replenished after each use to ensure a state of readiness. The Town of Farmville reserves the right to request, but shall not require, funding from the participating localities should operating and maintenance expenditures become excessive.



 Farmville Town Manager



 Farmville Volunteer Fire Department, Chief

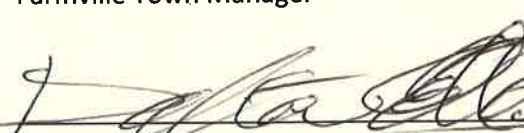

 Pamplin Volunteer Fire Department, Chief

02-04-16

 DATE



Memorandum of Understanding
 Multi-Jurisdictional Regional Fire Training Partnership
 For Use of a Vehicle Fire Training Prop
 Between
 The Town of Farmville, Farmville Volunteer Fire Department
 And
 Prospect Volunteer Fire Department



Purpose:

The Town of Farmville and the Farmville Fire Department recognizes the value of a regional partnership in fire service related training as well as Virginia Department of Fire Programs Certification Training. The purpose of this Memorandum of Understanding (MOU) is to provide an outline for the use of a vehicle fire training prop used by multiple jurisdictions to enhance fire training in the Division 3 Area.

Scope:

This MOU provides that the Town of Farmville will maintain the fire training prop and provide the participating fire departments with access to the training prop as needed, unless otherwise in use. The participating fire department shall be responsible for the replacement of fuel for the training prop. Also the liability shall be assumed by the participating fire department utilizing the training prop. While the lead fire department participants (Town of Farmville, Charlotte, Cumberland and Prince Edward Counties) shall be the primary users, the prop will be made available upon request and at the discretion of the Town of Farmville. Agencies shall operate under the same guidelines as provided and a qualified operator shall be onsite to oversee the training operation.

Term:

The period of the MOU shall be based on the fiscal year, beginning on July 1st of the current year and end on June 30th of the following year. The MOU shall be evaluated each year and any changes shall be incorporated into the next year's MOU. The agreement shall exist for the serviceable life of the prop.

Monetary Terms:

This MOU further outlines that each use of the training prop shall be documented and the amount of propane used shall be replenished after each use to ensure a state of readiness. The Town of Farmville reserves the right to request, but shall not require, funding from the participating localities should operating and maintenance expenditures become excessive.



 Farmville Town Manager

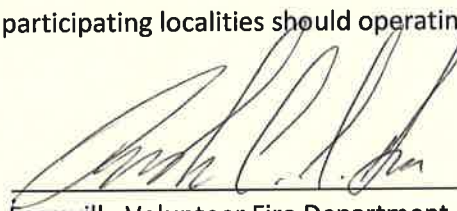

 Farmville Volunteer Fire Department, Chief

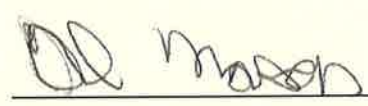

 Prospect Volunteer Fire Department, Chief

2-2-2016

 DATE



Memorandum of Understanding
 Multi-Jurisdictional Regional Fire Training Partnership
 For Use of a Vehicle Fire Training Prop
 Between
 The Town of Farmville, Farmville Volunteer Fire Department
 And
 Rice Volunteer Fire Department



Purpose:

The Town of Farmville and the Farmville Fire Department recognizes the value of a regional partnership in fire service related training as well as Virginia Department of Fire Programs Certification Training. The purpose of this Memorandum of Understanding (MOU) is to provide an outline for the use of a vehicle fire training prop used by multiple jurisdictions to enhance fire training in the Division 3 Area.

Scope:

This MOU provides that the Town of Farmville will maintain the fire training prop and provide the participating fire departments with access to the training prop as needed, unless otherwise in use. The participating fire department shall be responsible for the replacement of fuel for the training prop. Also the liability shall be assumed by the participating fire department utilizing the training prop. While the lead fire department participants (Town of Farmville, Charlotte, Cumberland and Prince Edward Counties) shall be the primary users, the prop will be made available upon request and at the discretion of the Town of Farmville. Agencies shall operate under the same guidelines as provided and a qualified operator shall be onsite to oversee the training operation.

Term:

The period of the MOU shall be based on the fiscal year, beginning on July 1st of the current year and end on June 30th of the following year. The MOU shall be evaluated each year and any changes shall be incorporated into the next year's MOU. The agreement shall exist for the serviceable life of the prop.

Monetary Terms:

This MOU further outlines that each use of the training prop shall be documented and the amount of propane used shall be replenished after each use to ensure a state of readiness. The Town of Farmville reserves the right to request, but shall not require, funding from the participating localities should operating and maintenance expenditures become excessive.



 Farmville Town Manager

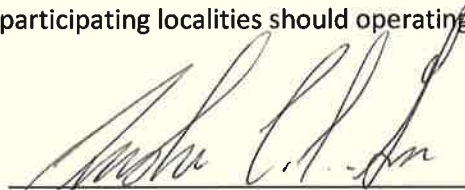

 Farmville Volunteer Fire Department, Chief



 Rice Volunteer Fire Department, Chief

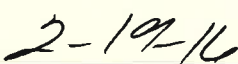

 DATE



Memorandum of Understanding
Multi-Jurisdictional Regional Fire Training Partnership
For Use of a Vehicle Fire Training Prop
Between
The Town of Farmville, Farmville Volunteer Fire Department
And
Charlotte County



Purpose:

The Town of Farmville and the Farmville Fire Department recognizes the value of a regional partnership in fire service related training as well as Virginia Department of Fire Programs Certification Training. The purpose of this Memorandum of Understanding (MOU) is to provide an outline for the use of a vehicle fire training prop used by multiple jurisdictions to enhance fire training in the Division 3 Area.

Scope:

This MOU provides that the Town of Farmville will maintain the fire training prop and provide the participating fire departments with access to the training prop as needed, unless otherwise in use. The participating fire department shall be responsible for the replacement of fuel for the training prop. Also the liability shall be assumed by the participating fire department utilizing the training prop. While the lead fire department participants (Town of Farmville, Charlotte, Cumberland and Prince Edward Counties) shall be the primary users, the prop will be made available upon request and at the discretion of the Town of Farmville. Agencies shall operate under the same guidelines as provided and a qualified operator shall be onsite to oversee the training operation.

Term:

The period of the MOU shall be based on the fiscal year, beginning on July 1st of the current year and end on June 30th of the following year. The MOU shall be evaluated each year and any changes shall be incorporated into the next year's MOU. The agreement shall exist for the serviceable life of the prop.

Monetary Terms:

This MOU further outlines that each use of the training prop shall be documented and the amount of propane used shall be replenished after each use to ensure a state of readiness. The Town of Farmville reserves the right to request, but shall not require, funding from the participating localities should operating and maintenance expenditures become excessive.

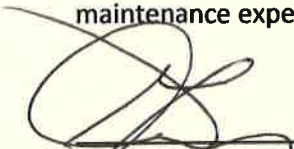

Farmville Town Manager



Farmville Volunteer Fire Department, Chief



Charlotte County Administrator

2/10/16

DATE



Memorandum of Understanding.
Multi-Jurisdictional Regional Fire Training Partnership
For Use of a Vehicle Fire Training Prop
Between
The Town of Farmville, Farmville Volunteer Fire Department
And
Bacon Volunteer Fire Department



Purpose:

The Town of Farmville and the Farmville Fire Department recognizes the value of a regional partnership in fire service related training as well as Virginia Department of Fire Programs Certification Training. The purpose of this Memorandum of Understanding (MOU) is to provide an outline for the use of a vehicle fire training prop used by multiple jurisdictions to enhance fire training in the Division 3 Area.

Scope:

This MOU provides that the Town of Farmville will maintain the fire training prop and provide the participating fire departments with access to the training prop as needed, unless otherwise in use. The participating fire department shall be responsible for the replacement of fuel for the training prop. Also the liability shall be assumed by the participating fire department utilizing the training prop. While the lead fire department participants (Town of Farmville, Charlotte, Cumberland and Prince Edward Counties) shall be the primary users, the prop will be made available upon request and at the discretion of the Town of Farmville. Agencies shall operate under the same guidelines as provided and a qualified operator shall be onsite to oversee the training operation.

Term:

The period of the MOU shall be based on the fiscal year, beginning on July 1st of the current year and end on June 30th of the following year. The MOU shall be evaluated each year and any changes shall be incorporated into the next year's MOU. The agreement shall exist for the serviceable life of the prop.

Monetary Terms:

This MOU further outlines that each use of the training prop shall be documented and the amount of propane used shall be replenished after each use to ensure a state of readiness. The Town of Farmville reserves the right to request, but shall not require, funding from the participating localities should operating and maintenance expenditures become excessive.



 Farmville Town Manager

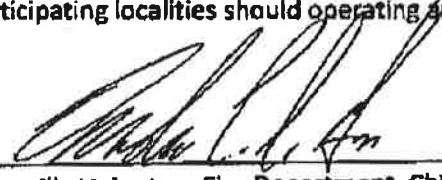

 Farmville Volunteer Fire Department, Chief



 Bacon Volunteer Fire Department, Chief

DATE - 19-2016



Memorandum of Understanding

Multi-Jurisdictional Regional Fire Training Partnership

For Use of a Vehicle Fire Training Prop

Between

The Town of Farmville, Farmville Volunteer Fire Department

And

Charlotte Court House Volunteer Fire Department



Purpose:

The Town of Farmville and the Farmville Fire Department recognizes the value of a regional partnership in fire service related training as well as Virginia Department of Fire Programs Certification Training. The purpose of this Memorandum of Understanding (MOU) is to provide an outline for the use of a vehicle fire training prop used by multiple jurisdictions to enhance fire training in the Division 3 Area.

Scope:

This MOU provides that the Town of Farmville will maintain the fire training prop and provide the participating fire departments with access to the training prop as needed, unless otherwise in use. The participating fire department shall be responsible for the replacement of fuel for the training prop. Also the liability shall be assumed by the participating fire department utilizing the training prop. While the lead fire department participants (Town of Farmville, Charlotte, Cumberland and Prince Edward Counties) shall be the primary users, the prop will be made available upon request and at the discretion of the Town of Farmville. Agencies shall operate under the same guidelines as provided and a qualified operator shall be onsite to oversee the training operation.

Term:

The period of the MOU shall be based on the fiscal year, beginning on July 1st of the current year and end on June 30th of the following year. The MOU shall be evaluated each year and any changes shall be incorporated into the next year's MOU. The agreement shall exist for the serviceable life of the prop.

Monetary Terms:

This MOU further outlines that each use of the training prop shall be documented and the amount of propane used shall be replenished after each use to ensure a state of readiness. The Town of Farmville reserves the right to request, but shall not require, funding from the participating localities should operating and maintenance expenditures become excessive.

Farmville Town Manager

Farmville Volunteer Fire Department, Chief

Charlotte C. H. Volunteer Fire Department, Chief

2/18/16

DATE



Memorandum of Understanding

Multi-Jurisdictional Regional Fire Training Partnership
For Use of a Vehicle Fire Training Prop
Between
The Town of Farmville, Farmville Volunteer Fire Department
And
Cullen Volunteer Fire Department



Purpose:

The Town of Farmville and the Farmville Fire Department recognizes the value of a regional partnership in fire service related training as well as Virginia Department of Fire Programs Certification Training. The purpose of this Memorandum of Understanding (MOU) is to provide an outline for the use of a vehicle fire training prop used by multiple jurisdictions to enhance fire training in the Division 3 Area.

Scope:

This MOU provides that the Town of Farmville will maintain the fire training prop and provide the participating fire departments with access to the training prop as needed, unless otherwise in use. The participating fire department shall be responsible for the replacement of fuel for the training prop. Also the liability shall be assumed by the participating fire department utilizing the training prop. While the lead fire department participants (Town of Farmville, Charlotte, Cumberland and Prince Edward Counties) shall be the primary users, the prop will be made available upon request and at the discretion of the Town of Farmville. Agencies shall operate under the same guidelines as provided and a qualified operator shall be onsite to oversee the training operation.

Term:

The period of the MOU shall be based on the fiscal year, beginning on July 1st of the current year and end on June 30th of the following year. The MOU shall be evaluated each year and any changes shall be incorporated into the next year's MOU. The agreement shall exist for the serviceable life of the prop.

Monetary Terms:

This MOU further outlines that each use of the training prop shall be documented and the amount of propane used shall be replenished after each use to ensure a state of readiness. The Town of Farmville reserves the right to request, but shall not require, funding from the participating localities should operating and maintenance expenditures become excessive.

Farmville Town Manager

Farmville Volunteer Fire Department, Chief

Cullen Volunteer Fire Department, Chief

2-4-14

DATE



Memorandum of Understanding

Multi-Jurisdictional Regional Fire Training Partnership

For Use of a Vehicle Fire Training Prop

Between

The Town of Farmville, Farmville Volunteer Fire Department

And

Drakes Branch Volunteer Fire Department



Purpose:

The Town of Farmville and the Farmville Fire Department recognizes the value of a regional partnership in fire service related training as well as Virginia Department of Fire Programs Certification Training. The purpose of this Memorandum of Understanding (MOU) is to provide an outline for the use of a vehicle fire training prop used by multiple jurisdictions to enhance fire training in the Division 3 Area.

Scope:

This MOU provides that the Town of Farmville will maintain the fire training prop and provide the participating fire departments with access to the training prop as needed, unless otherwise in use. The participating fire department shall be responsible for the replacement of fuel for the training prop. Also the liability shall be assumed by the participating fire department utilizing the training prop. While the lead fire department participants (Town of Farmville, Charlotte, Cumberland and Prince Edward Counties) shall be the primary users, the prop will be made available upon request and at the discretion of the Town of Farmville. Agencies shall operate under the same guidelines as provided and a qualified operator shall be onsite to oversee the training operation.

Term:

The period of the MOU shall be based on the fiscal year, beginning on July 1st of the current year and end on June 30th of the following year. The MOU shall be evaluated each year and any changes shall be incorporated into the next year's MOU. The agreement shall exist for the serviceable life of the prop.

Monetary Terms:

This MOU further outlines that each use of the training prop shall be documented and the amount of propane used shall be replenished after each use to ensure a state of readiness. The Town of Farmville reserves the right to request, but shall not require, funding from the participating localities should operating and maintenance expenditures become excessive.

Farmville Town Manager

Farmville Volunteer Fire Department, Chief

Drakes Branch Volunteer Fire Department, Chief

2-10-16

DATE



Memorandum of Understanding

Multi-Jurisdictional Regional Fire Training Partnership

For Use of a Vehicle Fire Training Prop

Between

The Town of Farmville, Farmville Volunteer Fire Department

And

Keyville Volunteer Fire Department



Purpose:

The Town of Farmville and the Farmville Fire Department recognizes the value of a regional partnership in fire service related training as well as Virginia Department of Fire Programs Certification Training. The purpose of this Memorandum of Understanding (MOU) is to provide an outline for the use of a vehicle fire training prop used by multiple jurisdictions to enhance fire training in the Division 3 Area.

Scope:

This MOU provides that the Town of Farmville will maintain the fire training prop and provide the participating fire departments with access to the training prop as needed, unless otherwise in use. The participating fire department shall be responsible for the replacement of fuel for the training prop. Also the liability shall be assumed by the participating fire department utilizing the training prop. While the lead fire department participants (Town of Farmville, Charlotte, Cumberland and Prince Edward Counties) shall be the primary users, the prop will be made available upon request and at the discretion of the Town of Farmville. Agencies shall operate under the same guidelines as provided and a qualified operator shall be onsite to oversee the training operation.

Term:

The period of the MOU shall be based on the fiscal year, beginning on July 1st of the current year and end on June 30th of the following year. The MOU shall be evaluated each year and any changes shall be incorporated into the next year's MOU. The agreement shall exist for the serviceable life of the prop.

Monetary Terms:

This MOU further outlines that each use of the training prop shall be documented and the amount of propane used shall be replenished after each use to ensure a state of readiness. The Town of Farmville reserves the right to request, but shall not require, funding from the participating localities should operating and maintenance expenditures become excessive.

Farmville Town Manager

Farmville Volunteer Fire Department, Chief

Keyville Volunteer Fire Department, Chief

2/22/2016

DATE



Memorandum of Understanding
 Multi-Jurisdictional Regional Fire Training Partnership
 For Use of a Vehicle Fire Training Prop
 Between
 The Town of Farmville, Farmville Volunteer Fire Department
 And
 Phenix Volunteer Fire Department



Purpose:

The Town of Farmville and the Farmville Fire Department recognizes the value of a regional partnership in fire service related training as well as Virginia Department of Fire Programs Certification Training. The purpose of this Memorandum of Understanding (MOU) is to provide an outline for the use of a vehicle fire training prop used by multiple jurisdictions to enhance fire training in the Division 3 Area.

Scope:

This MOU provides that the Town of Farmville will maintain the fire training prop and provide the participating fire departments with access to the training prop as needed, unless otherwise in use. The participating fire department shall be responsible for the replacement of fuel for the training prop. Also the liability shall be assumed by the participating fire department utilizing the training prop. While the lead fire department participants (Town of Farmville, Charlotte, Cumberland and Prince Edward Counties) shall be the primary users, the prop will be made available upon request and at the discretion of the Town of Farmville. Agencies shall operate under the same guidelines as provided and a qualified operator shall be onsite to oversee the training operation.

Term:

The period of the MOU shall be based on the fiscal year, beginning on July 1st of the current year and end on June 30th of the following year. The MOU shall be evaluated each year and any changes shall be incorporated into the next year's MOU. The agreement shall exist for the serviceable life of the prop.

Monetary Terms:

This MOU further outlines that each use of the training prop shall be documented and the amount of propane used shall be replenished after each use to ensure a state of readiness. The Town of Farmville reserves the right to request, but shall not require, funding from the participating localities should operating and maintenance expenditures become excessive.



 Farmville Town Manager

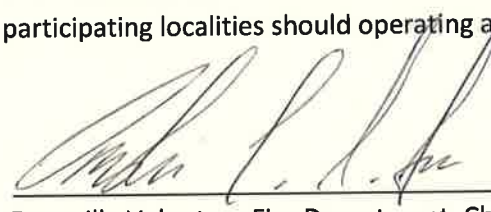

 Farmville Volunteer Fire Department, Chief



 Phenix Volunteer Fire Department, Chief

2-1-16

 DATE



Memorandum of Understanding

Multi-Jurisdictional Regional Fire Training Partnership
For Use of a Vehicle Fire Training Prop

Between

The Town of Farmville, Farmville Volunteer Fire Department

And

Red House Volunteer Fire Department



Purpose:

The Town of Farmville and the Farmville Fire Department recognizes the value of a regional partnership in fire service related training as well as Virginia Department of Fire Programs Certification Training. The purpose of this Memorandum of Understanding (MOU) is to provide an outline for the use of a vehicle fire training prop used by multiple jurisdictions to enhance fire training in the Division 3 Area.

Scope:

This MOU provides that the Town of Farmville will maintain the fire training prop and provide the participating fire departments with access to the training prop as needed, unless otherwise in use. The participating fire department shall be responsible for the replacement of fuel for the training prop. Also the liability shall be assumed by the participating fire department utilizing the training prop. While the lead fire department participants (Town of Farmville, Charlotte, Cumberland and Prince Edward Counties) shall be the primary users, the prop will be made available upon request and at the discretion of the Town of Farmville. Agencies shall operate under the same guidelines as provided and a qualified operator shall be onsite to oversee the training operation.

Term:

The period of the MOU shall be based on the fiscal year, beginning on July 1st of the current year and end on June 30th of the following year. The MOU shall be evaluated each year and any changes shall be incorporated into the next year's MOU. The agreement shall exist for the serviceable life of the prop.

Monetary Terms:

This MOU further outlines that each use of the training prop shall be documented and the amount of propane used shall be replenished after each use to ensure a state of readiness. The Town of Farmville reserves the right to request, but shall not require, funding from the participating localities should operating and maintenance expenditures become excessive.

Farmville Town Manager

Farmville Volunteer Fire Department, Chief

Red House Volunteer Fire Department, Chief

DATE



Memorandum of Understanding
Multi-Jurisdictional Regional Fire Training Partnership
For Use of a Vehicle Fire Training Prop



Between
The Town of Farmville, Farmville Volunteer Fire Department
And
Cumberland County

Purpose:

The Town of Farmville and the Farmville Fire Department recognizes the value of a regional partnership in fire service related training as well as Virginia Department of Fire Programs Certification Training. The purpose of this Memorandum of Understanding (MOU) is to provide an outline for the use of a vehicle fire training prop used by multiple jurisdictions to enhance fire training in the Division 3 Area.

Scope:

This MOU provides that the Town of Farmville will maintain the fire training prop and provide the participating fire departments with access to the training prop as needed, unless otherwise in use. The participating fire department shall be responsible for the replacement of fuel for the training prop. Also the liability shall be assumed by the participating fire department utilizing the training prop. While the lead fire department participants (Town of Farmville, Charlotte, Cumberland and Prince Edward Counties) shall be the primary users, the prop will be made available upon request and at the discretion of the Town of Farmville. Agencies shall operate under the same guidelines as provided and a qualified operator shall be onsite to oversee the training operation.

Term:

The period of the MOU shall be based on the fiscal year, beginning on July 1st of the current year and end on June 30th of the following year. The MOU shall be evaluated each year and any changes shall be incorporated into the next year's MOU. The agreement shall exist for the serviceable life of the prop.

Monetary Terms:

This MOU further outlines that each use of the training prop shall be documented and the amount of propane used shall be replenished after each use to ensure a state of readiness. The Town of Farmville reserves the right to request, but shall not require, funding from the participating localities should operating and maintenance expenditures become excessive.

Farmville Town Manager

Farmville Volunteer Fire Department, Chief

Cumberland County Administrator

2/12/2016

DATE



Memorandum of Understanding

Multi-Jurisdictional Regional Fire Training Partnership

For Use of a Vehicle Fire Training Prop

Between

The Town of Farmville, Farmville Volunteer Fire Department

And

Cumberland Volunteer Fire Department



Purpose:

The Town of Farmville and the Farmville Fire Department recognizes the value of a regional partnership in fire service related training as well as Virginia Department of Fire Programs Certification Training. The purpose of this Memorandum of Understanding (MOU) is to provide an outline for the use of a vehicle fire training prop used by multiple jurisdictions to enhance fire training in the Division 3 Area.

Scope:

This MOU provides that the Town of Farmville will maintain the fire training prop and provide the participating fire departments with access to the training prop as needed, unless otherwise in use. The participating fire department shall be responsible for the replacement of fuel for the training prop. Also the liability shall be assumed by the participating fire department utilizing the training prop. While the lead fire department participants (Town of Farmville, Charlotte, Cumberland and Prince Edward Counties) shall be the primary users, the prop will be made available upon request and at the discretion of the Town of Farmville. Agencies shall operate under the same guidelines as provided and a qualified operator shall be onsite to oversee the training operation.

Term:

The period of the MOU shall be based on the fiscal year, beginning on July 1st of the current year and end on June 30th of the following year. The MOU shall be evaluated each year and any changes shall be incorporated into the next year's MOU. The agreement shall exist for the serviceable life of the prop.

Monetary Terms:

This MOU further outlines that each use of the training prop shall be documented and the amount of propane used shall be replenished after each use to ensure a state of readiness. The Town of Farmville reserves the right to request, but shall not require, funding from the participating localities should operating and maintenance expenditures become excessive.

Farmville Town Manager

Farmville Volunteer Fire Department, Chief

Cumberland Volunteer Fire Department, Chief

2-03-2016

DATE



Memorandum of Understanding

Multi-Jurisdictional Regional Fire Training Partnership

For Use of a Vehicle Fire Training Prop

Between

The Town of Farmville, Farmville Volunteer Fire Department

And

Cartersville Volunteer Fire Department



Purpose:

The Town of Farmville and the Farmville Fire Department recognizes the value of a regional partnership in fire service related training as well as Virginia Department of Fire Programs Certification Training. The purpose of this Memorandum of Understanding (MOU) is to provide an outline for the use of a vehicle fire training prop used by multiple jurisdictions to enhance fire training in the Division 3 Area.

Scope:

This MOU provides that the Town of Farmville will maintain the fire training prop and provide the participating fire departments with access to the training prop as needed, unless otherwise in use. The participating fire department shall be responsible for the replacement of fuel for the training prop. Also the liability shall be assumed by the participating fire department utilizing the training prop. While the lead fire department participants (Town of Farmville, Charlotte, Cumberland and Prince Edward Counties) shall be the primary users, the prop will be made available upon request and at the discretion of the Town of Farmville. Agencies shall operate under the same guidelines as provided and a qualified operator shall be onsite to oversee the training operation.

Term:

The period of the MOU shall be based on the fiscal year, beginning on July 1st of the current year and end on June 30th of the following year. The MOU shall be evaluated each year and any changes shall be incorporated into the next year's MOU. The agreement shall exist for the serviceable life of the prop.

Monetary Terms:

This MOU further outlines that each use of the training prop shall be documented and the amount of propane used shall be replenished after each use to ensure a state of readiness. The Town of Farmville reserves the right to request, but shall not require, funding from the participating localities should operating and maintenance expenditures become excessive.

Farmville Town Manager

Farmville Volunteer Fire Department, Chief

Cartersville Volunteer Fire Department, Chief

2-3-16

DATE



Memorandum of Understanding

Multi-Jurisdictional Regional Fire Training Partnership
For Use of a Vehicle Fire Training Prop

Between

The Town of Farmville, Farmville Volunteer Fire Department
And
Randolph Volunteer Fire Department



Purpose:

The Town of Farmville and the Farmville Fire Department recognizes the value of a regional partnership in fire service related training as well as Virginia Department of Fire Programs Certification Training. The purpose of this Memorandum of Understanding (MOU) is to provide an outline for the use of a vehicle fire training prop used by multiple jurisdictions to enhance fire training in the Division 3 Area.

Scope:

This MOU provides that the Town of Farmville will maintain the fire training prop and provide the participating fire departments with access to the training prop as needed, unless otherwise in use. The participating fire department shall be responsible for the replacement of fuel for the training prop. Also the liability shall be assumed by the participating fire department utilizing the training prop. While the lead fire department participants (Town of Farmville, Charlotte, Cumberland and Prince Edward Counties) shall be the primary users, the prop will be made available upon request and at the discretion of the Town of Farmville. Agencies shall operate under the same guidelines as provided and a qualified operator shall be onsite to oversee the training operation.

Term:

The period of the MOU shall be based on the fiscal year, beginning on July 1st of the current year and end on June 30th of the following year. The MOU shall be evaluated each year and any changes shall be incorporated into the next year's MOU. The agreement shall exist for the serviceable life of the prop.

Monetary Terms:

This MOU further outlines that each use of the training prop shall be documented and the amount of propane used shall be replenished after each use to ensure a state of readiness. The Town of Farmville reserves the right to request, but shall not require, funding from the participating localities should operating and maintenance expenditures become excessive.

Farmville Town Manager

Farmville Volunteer Fire Department, Chief

Randolph Volunteer Fire Department, Chief

2/7/16

DATE

ATTACHMENT
Cost Estimates/Quotes For
Vehicle Training Prop and Trailer

Four (4) vendors were contacted requesting quotes for the car fire training prop.
Two (2) vendors were responsive and submitted the following quotes:

- | | |
|--------------|-------------------------------|
| 1. BullEx | \$46,816 (<i>low quote</i>) |
| 2. Fireblast | \$52,740 |
| 3. Draeger | Non responsive |
| 4. Kidde | Non responsive |

Farmville Volunteer Fire Department

ADVANCED VEHICLE FIRE TRAINING PROP

Budgetary Proposal

1-29-2016



Quote Number: 85094

Date: 1-29-2016

Sales Person: Kathy Plant

Valid Until: May 30th 2016

Terms: See General Terms and Conditions

Contact: Dean Farmer

Address: 1000 West 3rd Street

Farmville VA 23901

Email: ffd130@hotmail.com



BullEx[®]

Greetings

BullEx is proud to provide the following offer. Our advanced Vehicle Fire Training System is designed to provide realistic live fire training suited to your specific needs. BullEx offers smashable headlights, pry-able hood and an integrated cooling system as standard features of our vehicle prop package. Note that all BullEx props are covered by a ten year construction warranty. In addition, the pilot box, control console and all associated components are covered by a one year comprehensive warranty. The specifications and the corresponding BullEx offer are summarized below.

BullEx Vehicle Fire Training System Package

Price: \$39,895

The BullEx Vehicle Fire Training System includes:

BullEx Car Fire Prop

- **10-year construction warranty**
- **1/4" and 1/8" all steel construction with protective heat resistant paint**
- **1/3" C Channel galvanized steel frame. Thicker gauge steel at high heat areas allows for much longer life of car.**
- **Industrial gauge integrated steel casters for moving car prop**
- **Car prop dimensions: 12'6"l x 5' 6"w x 4'6"h**
- **4 burn zones** - Create passenger compartment, engine, wheel-well and trunk fires at the push of a button
- **Live fire training prop used in conjunction with Hose Line Fire Training System**
- **Hinged hood, trunk, and passenger doors**
- **Driver and passenger seat backs, steering wheel, hood prop bar**
- **Pry-able and Roll-able Hood** - Conduct forcible hood entry drills with the Pry-able and Roll-able Hood feature. The special design with replaceable hood plates of varying difficulty allows for challenging yet repeatable hood-rolling drills without damaging the prop.
- **Integrated Cooling System** - Cooling piping is built into the vehicle itself and connects to a standard garden hose, allowing for long duration fire simulations while minimizing steel fatigue and wear. Ideal



for use when practicing positioning of apparatus, angle of attack, and stretching the proper hose lines, etc. while the vehicle remains fully involved.

- **Smashable Headlights** - Conduct engine compartment extinguishing drills with the Smashable Headlights feature. Specially designed headlight holes in the grill allow for drills of varying difficulty with different types of metal headlight plates.
- All steel construction



Fire Tray and Pilot Control Box

- Removable tray can be positioned independently to simulate a fuel spill or can be used in conjunction with several other BullEx training props
- Engineered for use with hand lines, CO2, and water extinguishers
- Liquid propane fueled industrial grade fire fighter training unit
- Stainless steel 4' x 6' fire tray
- **CSA Listed and Approved stainless steel** continuous burn forced air pilot control box with four (4) burn zones for realistic fire simulation
- Removable pilot box can also be used with other BullEx props or fire trays

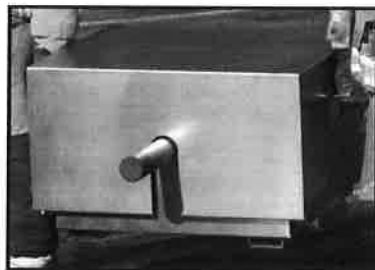

Mobile Control Console

- **UL Approved Control Console** interfaces between props and upstream propane and power supply. Houses core propane and power components, control components, optional wireless and sound effect components (if selected), and **built in E-stop button**.
- Includes 50 foot propane hose with **self-sealing quick disconnect fittings**, specifically designed to prevent gas leaks up to 250psi in high-pressure propane delivery situations. Hose and fittings



constructed to withstand environment elements and heat from normal operation.

- **NEMA 4X** rated to resist corrosion
- Wired remote (unless upgraded to wireless) to independently start and stop multiple burn zones, with deadman button
- Includes power cable to connect to customers power supply

Wireless Control Option

Rugged, industrial grade hand-held wireless remote control. Controls fire simulation systems including four fire zones and add-on fires, and optional features such as smoke effects, and sound effects. Stop button for rapid shutdown. Option will allow operation of one prop at a time.

Price: \$4,195



Installation, Set-up and Training

Price: \$2,726

Installation and calibration. Includes:

- Delivery to site
- Set-up and test operation of all props
- 4 hour train the trainer session for up to 10 people
- User manual
- Toll-Free technical support
- One year comprehensive warranty on materials and parts
- Ten year construction warranty on the steel vehicle prop
- Site work not included. It is the responsibility of the customer to provide propane and electricity to the console.

BullEx Vehicle Prop	\$39,895
Wireless Remote Control	\$4,195
Installation, Set-up and Training	\$2,726
TOTAL	\$46,816

Our Approach

Realism

BullEx Training Systems are designed to simulate every aspect of a fire or emergency response situation. The fire training systems, structures, and their interior props are constructed accurately to scale, and the fires are built into objects and appliances that would be found in real life. BullEx focuses on building the most realistic fire training scenarios possible allowing trainees to experience the full impact of an emergency situation. Every critical environmental condition that a first responder may face during an emergency can be simulated, including darkness, smoke, sound, flames and heat – depending on the scenario desired. As a result, trainees come to fully experience the challenging physical and psychological effects both on themselves and on others participating in the exercise. Wherever possible, technical instruments and services such as gas and electrical supplies, ventilation systems, and pilot burners are “hidden” from view using special design elements and technologies.

Integrated focus on safety and performance

BullEx training systems are designed, built and installed to ensure that all safety controls are integrated directly into the operational device. Our technicians calibrate the safety settings for each module to maximize safety and ensure all training situations are of a consistent and high quality. BullEx systems are CSA and UL/ULC approved. BullEx's in-house technical support team is completely familiar with all the details of your system and is on-call to provide the maintenance and service your training requires.

Effective training

Most importantly, the training system you acquire needs to be designed to effectively teach the lessons important for your actual risk and response situation. The training simulator must be a tool that addresses your training needs and serves as a way to support the educational program of your instructors. BullEx is focused on designing systems that help you teach the critical fire and safety skills needed to address your highest risk elements.

Experience

BullEx is a market leader in the field of fire and safety training equipment. Headquartered in New York, with offices in nine countries worldwide, BullEx serves a global customer base with its best-of-class training technologies. Used by thousands of organizations to train millions of fire and safety professionals, BullEx fire training systems have become the industry standard.

Industry Recognition

Our Bullex products have received numerous industry recognitions and awards, including (among others):

- Manufacturing Leadership Awards – New Product Leadership - 2015
- Prestigious Build Award for Excellence in Design and Construction – 2014
- Industry Awards from 2010-2013
- Occupational Safety and Health Magazine – New Product of the Year – 2009
- Australia Fire Awareness Award – 2008
- National Registry of Environmental Professional – Environmental Training Award 2007

We offer a total solutions product line for firefighter training, fire brigade training, fire prevention public education and corporate safety training.

Bullex clients include every branch of the US armed forces, the US Department of Homeland Security, NASA, and thousands of other fire departments, government offices, and corporate clients.



Contact

Seeing is believing. We hope that this proposal offers us an opportunity to show how BullEx's advanced fire trainer can help Chief Farmer achieve your training goals.

Thank you for considering BullEx as a trusted source for your fire training. It has been an honor for us to provide you with this budgetary proposal.

Please do not hesitate to contact us should you require any more information or have any questions about the proposal provided or our company.

Kathy Plant
Regional Sales Manager
VA, OH, MD, KY

20 Corporate Circle
Albany, NY 12203
Tel: 518.689.2023
Fax: 518.689.2034
www.bullex.com





January 29, 2016

Dean Farmer
Farmville Fire Department

Sir,

Thank you for the opportunity to provide your department a pricing proposal in regards to your needs as a department and county. As you are aware, while we have two lines of exterior systems, I have attached pricing for our Falcon DX car, which can be added on to as future funding becomes available.

Fireblast Global is the premier manufacturer providing Advanced Live Fire Training props, specializing in the design and production of fire training equipment for Municipal, Civil Aviation, Oil and Gas, Industrial, Institutional, and Civil Defense sectors. Our staff designs, engineers, manufactures, and supports the broadest range of fire training products available. We look forward to meeting and exceeding your expectations.

Please feel free to contact the undersigned at 951.277.8319 or pellis@fireblast.com any time should you have any questions.

Sincerely,

A handwritten signature in black ink, appearing to read "P. Ellis", is written over a light blue horizontal line.

Paul Ellis
Regional Sales Executive
Fireblast Global

**Q8563-PE-29Jan2016
Proposal for Falcon EX Exterior Props
For Farmville Fire Department**

Item	Description	Price (USD)
1	Falcon EX Props Control System <u>Falcon EX Controller Dual</u> <ul style="list-style-type: none"> ▪ PLC-computer Controls ▪ Wireless push button design ▪ Wireless provides computer controlled increases for flame intensity ▪ Pilot verification ▪ System reset ▪ Capable of controlling 2 ignitors ▪ E-Stop on wireless control 	\$6,325.00
2	<u>Falcon EX Pan</u> <ul style="list-style-type: none"> ▪ 6 x 4 pan size (24 square feet) ▪ Operates with included ignitor 	\$6,110.00
3	<u>Falcon EX Ignitor</u>	\$9,435.00
4	<u>Falcon EX Car Prop</u> <ul style="list-style-type: none"> ▪ Realistic 4 Door car prop ▪ To be utilized with included ignitor 	\$20,935.00
5	Shipping	\$9,935.00
SUB-TOTAL for Items 1 – 5		\$52,740.00

Terms & Conditions:

Price valid through 31 December 2016

Lead times vary. 6 months after acceptance of order

Payment Terms: 30% on order, 50% on completion, 20% upon completion of training. Net 30.

Warranty: 1-year limited parts warranty and technical phone support.

Subject to Fireblast Standard Terms & Conditions.

Inclusions:

Commissioning and training

Wireless controls

Exclusions:

Propane Supply & Storage System

Offloading from truck at site

Payment/performance bond, taxes, duties, tariffs, customs fees, permits, and fees, if applicable

Falcon EX Series Exterior Props

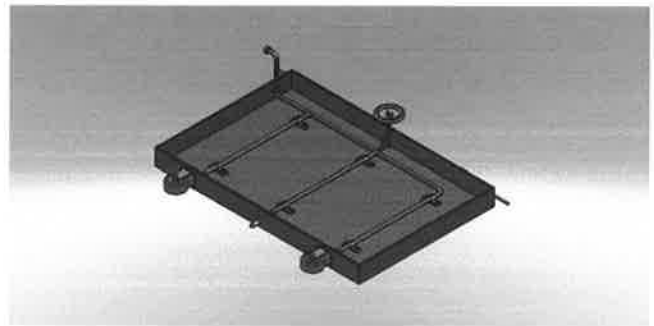
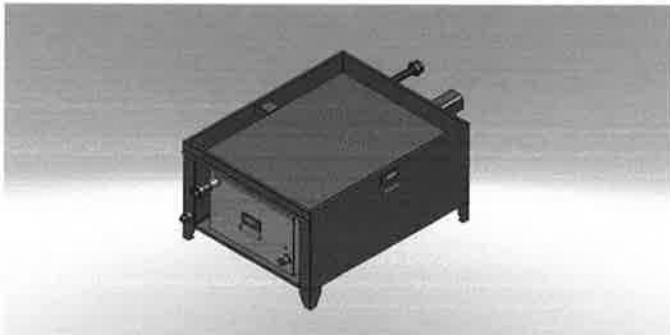
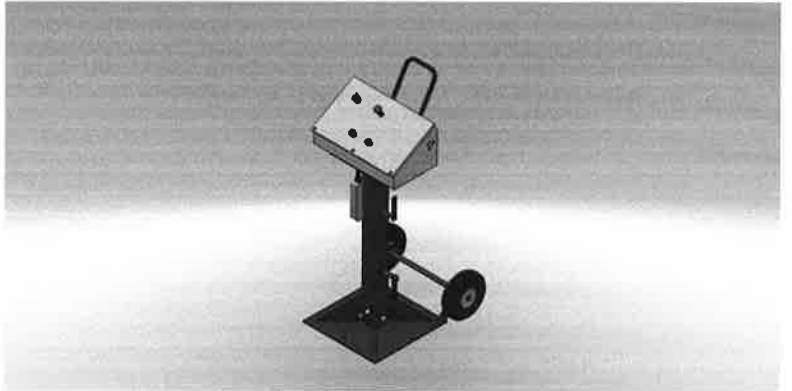

**Q8563-PE-29Jan2016
Proposal for Falcon DX Car
for Farmville Fire Department**

Item	Description	Price
1	<p>Falcon DX Car Trainer</p> <p><u>Live Fire Prop</u></p> <ul style="list-style-type: none"> ▪ Car Prop to resemble mid size vehicle body ▪ 4 fully independent burn zones (engine, passenger, rear tire, fuel tank fire) ▪ Consist of corrosion resistant steel construction ▪ Operating hood and doors ▪ Propane gas supply hoses for prop <p><u>Industrial Controls</u></p> <ul style="list-style-type: none"> ▪ PLC-computer Controls w/ Burner Management System ▪ Wireless push button design ▪ Computer controlled flame for increase in flame intensity ▪ Pilot verification ▪ System reset <p><u>Safety Systems</u></p> <ul style="list-style-type: none"> ▪ Certification by an OSHA-recognized NRTL ▪ Independent, Monitored & Interlocked Pilot ▪ Fail-safe Valves ▪ E-Stop on wireless control <p><u>Maintenance & Support</u></p> <ul style="list-style-type: none"> ▪ 8-hour Operation & Maintenance Training Course for up to (8) Students ▪ Full Color O&M Manuals (10 copies) ▪ 24/7 Technical Phone Support 	\$94,628
3	Option: Add Enclosed 28ft Trailer Package (Self Contained)	\$32,227
4	Option: Add Additional Interchangeable Fire Props	Upon Request

Terms & Conditions:

Price valid through 31 December 2016
Lead times vary. 6 months after acceptance of order
Payment Terms: 30% on order, 50% on completion, 20% upon completion of training. Net 30.
Warranty: 1-year limited parts warranty and technical phone support.
Subject to Fireblast Standard Terms & Conditions.

Inclusions:

PLC controls, Wireless controller, NFPA-compliant safety systems
Applications engineering support, installation, commissioning and training

Exclusions:

Propane Source Supply & Storage System
Offloading from truck at site

Falcon DX Car



Three (3) vendors were contacted requesting quotes for the 18' trailer.
Three (3) vendors were responsive and submitted the following quotes:

- | | |
|-------------------------------------|---------------------------------|
| 1. New London Trailers, Inc. | \$2,295.00 (<i>low quote</i>) |
| 2. Pro-line Trailer Sales | \$2,599.99 |
| 3. Taylor-Forbes equipment Co. Inc. | \$2,690.00 |

NEW LONDON TRAILERS INC

13001 EAST LYNCHBURG-SALEM TPKE.

FOREST, VA 24551

(434) 525-1211

FAX (434) 525-4162

To: Dean Farmer

From: Tom Roberts

Date: February 2, 2016

Re: Trailer quote

The following quote is for a Carolina brand car hauler with the following specifications:

2 – 3500 lb axles (1 brake axle, 1 idler axle)

7000 lb GVWR

2 5/16 ball coupler

Treated wood floor

2' dove tail

4' slide in ramps

DOT compliant lighting

2K A frame jack

Stake pockets

Tear drop fenders

ST205/75D15 6 ply tires

Price:

16 foot: \$2095.00

18 foot: \$2295.00

[Trailers \(https://www.prolinetrailersales.com/trailers\)](https://www.prolinetrailersales.com/trailers)

[Service & Repair \(https://www.prolinetrailersales.com/service\)](https://www.prolinetrailersales.com/service)

[Specials \(https://www.prolinetrailersales.com/specials\)](https://www.prolinetrailersales.com/specials)

[Accessories \(https://www.prolinetrailersales.com/accessories\)](https://www.prolinetrailersales.com/accessories)

[Used Trailers \(https://www.prolinetrailersales.com/used-trailers\)](https://www.prolinetrailersales.com/used-trailers)

[About Pro-Line \(https://www.prolinetrailersales.com/about\)](https://www.prolinetrailersales.com/about)

[Contact \(https://www.prolinetrailersales.com/contact\)](https://www.prolinetrailersales.com/contact)

Enclosed Trailers
 [\(https://www.prolinetrailersales.com/enclosed-trailers\)](https://www.prolinetrailersales.com/enclosed-trailers)

Open Car Trailers
 [\(https://www.prolinetrailersales.com/open-trailers/car-trailers\)](https://www.prolinetrailersales.com/open-trailers/car-trailers)

Equipment Trailers
 [\(https://www.prolinetrailersales.com/open-trailers/equipment-trailers\)](https://www.prolinetrailersales.com/open-trailers/equipment-trailers)

7x18 Car Trailer \$2,599.99

7x18 Open (<https://www.prolinetrailersales.com/open-trailers/car-trailers>) Car Hauler

Boones Mill, VA

(AD#: 240032)

0 Down Financing (wac)

\$2,599.99

[\(https://www.prolinetrailersales.com/trailers/car-trailers/7x18-car-trailer-2\)](https://www.prolinetrailersales.com/trailers/car-trailers/7x18-car-trailer-2)

Top Sellers

[\(https://www.prolinetrailersales.com/top-sellers\)](https://www.prolinetrailersales.com/top-sellers)

Used Trailers

[\(https://www.prolinetrailersales.com/used-trailers\)](https://www.prolinetrailersales.com/used-trailers)

Enclosed Trailers

[\(https://www.prolinetrailersales.com/enclosed-trailers\)](https://www.prolinetrailersales.com/enclosed-trailers)

Open Trailers

[\(https://www.prolinetrailersales.com/open-trailers\)](https://www.prolinetrailersales.com/open-trailers)

Specials

[\(https://www.prolinetrailersales.com/specials\)](https://www.prolinetrailersales.com/specials)

[Credit Application \(https://www.prolinetrailersales.com/credit-application\)](https://www.prolinetrailersales.com/credit-application)

Get a Quote  [\(/contact\)](/contact)

1 of 8

[\(https://www.prolinetrailersales.com/cms/wp-content/uploads/2014/07/2015-04-02-14.59.09-1024x768.jpg\)](https://www.prolinetrailersales.com/cms/wp-content/uploads/2014/07/2015-04-02-14.59.09-1024x768.jpg)

[← Prev](#) [Next →](#)
Features

- Dexter 3500# Axles
- Electric Brakes with Breakaway
- Dove/Beaver Tail
- 2000 lb tongue jack
- Pull Out Ramps
- LED Lights
- 15" tires

Quick Links

- Credit Application
(<https://www.prolinetrailersales.com/open-trailer-application>)
- Trailer Service & Repair
(<https://www.prolinetrailersales.com/trailer-service-repair>)
- Trailer Specials
(<https://www.prolinetrailersales.com/trailer-specials>)
- Trailer Options
(<https://www.prolinetrailersales.com/trailer-options>)
- Trailer Colors
(<https://www.prolinetrailersales.com/trailer-colors>)
- FAQ
(<https://www.prolinetrailersales.com/faq>)
- About Pro-Line®
(<https://www.prolinetrailersales.com/about-pro-line>)
- Contact Us
(<https://www.prolinetrailersales.com/contact>)

Featured Trailers

- Enclosed Trailers
(<https://www.prolinetrailersales.com/enclosed-trailers>)
- Car/Racing Trailers
(<https://www.prolinetrailersales.com/enclosed-trailers/enclosed-car-trailers>)
- Open Trailers
(<https://www.prolinetrailersales.com/open-trailer>)
- Utility Trailers
(<https://www.prolinetrailersales.com/open-trailer/utility-trailers>)
- Equipment Trailers
(<https://www.prolinetrailersales.com/open-trailer/equipment-trailers>)
- Livestock Trailers
(<https://www.prolinetrailersales.com/trailer-livestock>)
- Used Trailers
(<https://www.prolinetrailersales.com/used-trailers>)

Latest News

- Trailer Service & Parts Installation from A/C to Z-tech
(<https://www.prolinetrailersales.com/news/trailer-service-parts-installation-ac-z-tech>)
- Spring's Around The Corner - Custom Enclosed Trailers
(<https://www.prolinetrailersales.com/news/springs-around-the-corner-custom-enclosed-trailers>)
- Holiday Hours
(<https://www.prolinetrailersales.com/news/holiday-hours>)
- Trailer Financing & Featured Trailers at Pro-Line
(<https://www.prolinetrailersales.com/news/trailer-financing-featured-trailers-at-pro-line>)
- Car, Motorcycle & Truck Show for Rockbridge Area Hospice
(<https://www.prolinetrailersales.com/news/car-motorcycle-truck-show-benefit-for-rockbridge-area-hospice>)
- Motorcycle Season: Hauling & Protecting Your Ride
(<https://www.prolinetrailersales.com/news/fall-motorcycle-season-hauling-protecting-your-ride>)

Ready to Order? Have a Question? Call (844) 977-6546 (tel:+18449776546) or Contact Us (<https://www.prolinetrailersales.com/contact>). Pro-Line is a registered trademark of Pro-Line Trailers. Copyright © 2016 Pro-Line® Trailers. All Rights Reserved. Web Design (<http://www.theedesign.com/web-design>) & SEO (<http://www.theedesign.com/seo>) by TheeDesign Studio (<http://www.theedesign.com>).

 (<https://www.facebook.com/prolinetrailersales>)

 (<https://twitter.com/ProlineTrailers>)

 (<https://plus.google.com/+ProLineTrailersBoonesMill>)

Since 1944



Taylor-Forbes Equip Co., Inc.
P.O. Box 243
1102 East Third Street
Farmville, VA 23901
434.392.4139 ex 6

Prepared For:
Farmville Vol Fire Department
P O Bos 241
Farmville, VA 23901
Attn: Dean Farmer
[434.315.4204](tel:434.315.4204)
deanfarmer@farmvillefire.net

Prepared By: Earl Carter
Date: 2/2/2016
Quote Valid till 3/2/2016

Equipment: Currahee Trailer

Qty	Manufacturer	Description	Price	Ext Price
1	Currahee	C716 Car Hauler Trailer 82"x16' Deck Treated Floor 2 - 3500# Brake Axles 5' Slide-Out Ramps		\$ 2,590.00
1	Currahee	C718 Car Hauler Trailer 82"x18' Deck Treated Floor 2 - 3500# Brake Axles 5" Slide-Out Ramps		\$ 2,690.00

Total Equipment:

Miscellaneous:

Description	Amount
No tags or DMV	

Total Miscellaneous:

Quotation Summary:	Sales Price:	
	Sales Tax:	if applicable
	Sales Price + Tax:	

ATTACHMENT
Vehicle Fire Prop Training Plan



Multi-Jurisdictional Regional Fire Training Plan



For Propane-fed Mobile Vehicle Fire Prop

1. The Town of Farmville is currently in the process of completion of our Regional Fire Training Center. Due to this new opportunity to host interdepartmental training as well as Regional Training a vehicle fire training system would enhance our ability to provide those services.
2. Memorandums of Understanding have been established with Prince Edward County, Cumberland and Charlotte Counties. The Fire Departments in those jurisdictions have also been contacted and they have also signed a Memorandum of Understanding as well. This training system will be mobile and will be available to the localities participating as well as any Department of Fire Programs training being conducted.
3. The availability of providing quality fire suppression training not only for vehicle fires but the training system also has the capability of providing hose line training for firefighters. This training prop will provide quality training for this area for fire service personnel and enhance the capabilities of our regional training center.



General Instructions & Notices

- Applicants are directed to "**Regional Fire Services Training Facilities Grant Program Policy**" as amended for the current funding year which is incorporated by reference to all applications and any subsequent awards. (Such practices document is inclusive of all *terms & conditions*.)
- The filing of an application does not bind the Board to award nor the Department to pay any such grant.
- Incomplete applications and those received after the deadline will not be considered.
(Deadline) → **March 1, 2016** postmarked
- Completed applications executed by the competent authority will only be accepted directly from jurisdictions not fire departments.
- Timeliness of filing and subsequent receipt by the Agency are solely the applicant's responsibility – all applications must be completed in ink and sent directly to: **VDFP Grants and Local Aid Manager,**
Address → **1005 Technology Park Drive, Glen Allen VA 23059-4500**
- All decisions regarding grant awards made by the Board are final; applicants may appeal decisions in writing to the address provided above within 15 business days of the posting of awards.

A. Applicant Information

1. Title of Lead Jurisdiction Making Application (Check <input checked="" type="checkbox"/> only one, then make entry)	<input type="checkbox"/>	County of	
	<input checked="" type="checkbox"/>	City of	Galax
	<input type="checkbox"/>	Incorporated Town of	
2. Employer Identification Number (EIN)	[REDACTED]		
3. Principal Point of Contact	(Include salutation, name & title.) Mike Ayers		
4. Mailing Address (Include zip code) Identify COUNTY if appropriate	PO Box 147 Galax, VA 24333		
5. Telephone Number	(276)	235-9580	
6. FAX Number	(276)	236-1081	
7. Internet e-mail address	mayers@galaxva.com		

B. Additional Parties

	Identify ALL jurisdictions (Not Fire Departments) participating in the proposed project. Attach additional sheets as may be required.
1. Formal Agreement Among Parties	<p>In accordance with Program Policy, multi-jurisdictional regional training partnerships must be documented (e.g. MOA, MOU, etc.) as required supporting documentation to the Application for consideration of Program funding.</p> <p>A copy of the Agreement has been attached to this application. <input checked="" type="checkbox"/> Yes <input type="checkbox"/> No</p> <p><i>If a copy of the Agreement has not been attached as required supporting documentation, this Application will be considered incomplete and funding will not be approved.</i></p>

Department of Fire Programs

MAR 04 2016

Administration



{ Reproduce and complete as many additional blocs as may be necessary for complete disclosure. }

2a. Complete <u>one each</u> for ALL other Parties of Interest	Number 2 of a total of 3 parties to proposed project (Count the LEAD Locality as #1, thereby start with #2.)
2b. Title of Jurisdiction (Check <input checked="" type="checkbox"/> only one, then make entry)	<input type="checkbox"/> County of
	<input type="checkbox"/> City of
	<input checked="" type="checkbox"/> Incorporated Town of Hillsville
2c. Employer Identification Number (EIN)	[REDACTED]
2d. Principal Point of Contact	(Include salutation, name & title.) Mike Musser
2e. Mailing Address Identify COUNTY if appropriate -	(Include zip code+4) 115 Fulcher St Hillsville, VA 24343 Carroll
2f. Telephone Number	(276) 728-7322
2g. FAX Number	(276) 728-7811
2h. Internet e-mail address	michael.musser@vsp.virginia.gov

{ Reproduce and complete as many additional blocs as may be necessary for complete disclosure. }

2a. Complete <u>one each</u> for ALL other Parties of Interest	Number 3 of a total of 3 parties to proposed project (Count the LEAD Locality as #1, thereby start with #2.)
2b. Title of Jurisdiction (Check <input checked="" type="checkbox"/> only one, then make entry)	<input type="checkbox"/> County of
	<input type="checkbox"/> City of
	<input checked="" type="checkbox"/> Incorporated Town of Fries
2c. Employer Identification Number (EIN)	[REDACTED]
2d. Principal Point of Contact	(Include salutation, name & title.) Chad Stanley
2e. Mailing Address Identify COUNTY if appropriate -	(Include zip code+4) 832 E. Main St Fries, VA 24330 Grayson
2f. Telephone Number	(276) 744-2141
2g. FAX Number	(276) 744-2111
2h. Internet e-mail address	chadstanley@gcps.k12.va.us

{ Reproduce and complete as many additional blocs as may be necessary for complete disclosure. }

2a. Complete <u>one each</u> for ALL other Parties of Interest	Number <input type="text"/> of a total of <input type="text"/> parties to proposed project (Count the LEAD Locality as #1, thereby start with #2.)
2b. Title of Jurisdiction (Check <input checked="" type="checkbox"/> only one, then make entry)	<input type="checkbox"/> County of
	<input type="checkbox"/> City of
	<input type="checkbox"/> Incorporated Town of
2c. Employer Identification Number (EIN)	[REDACTED]
2d. Principal Point of Contact	(Include salutation, name & title.)
2e. Mailing Address Identify COUNTY if appropriate -	(Include zip code+4)
2f. Telephone Number	()
2g. FAX Number	()
2h. Internet e-mail address	

Administration

MAR 01 2015

Department of Fire Programs



C. Previous Applications/Awards

1.	Has the Applicant previously applied for a RFSTF Grant from the Board? - check <input checked="" type="checkbox"/> one	<input checked="" type="checkbox"/> No	<input type="checkbox"/> Yes
2.	Has the Applicant previously received a RFSTF Grant from the Board? - check <input checked="" type="checkbox"/> one	<input checked="" type="checkbox"/> No	<input type="checkbox"/> Yes

D. Project Title(s) and Description(s) Enter a descriptive 'Title' and brief Description for the lead training project and/or program proposed for funding from any Grant which may be awarded pursuant to this application.

(Project Title)	(Description)
1 Rappelling Tower Refurbishment	Sand blast (or suitable priming method) the existing 4 story rappelling tower located at the Galax Fire Department Regional Training Grounds.
Which statement best describes the above proposed project and/or program? check <input checked="" type="checkbox"/> one	
<input checked="" type="checkbox"/> New <input type="checkbox"/> Change to existing <input type="checkbox"/> Continuing	
Which statement best describes how many training programs may benefit from the proposal? check <input checked="" type="checkbox"/> one	
<input checked="" type="checkbox"/> Multiple Programs <input type="checkbox"/> Single Program	
Describe the impact on training if this Grant is not awarded, or check <input type="checkbox"/> No Significant Impact	
Ropes training, both in-house and formal VDFP, will be cease if this 4 story rappelling tower is not maintained. Currently, the paint on the structure is 30% gone with rust showing. Classes affected will include Intro to Technical Rescue, Ropes 1 and 2, and in-house training allowed throughout the year by any area jurisdiction.	
<input type="checkbox"/> ← Check <input checked="" type="checkbox"/> IF a Continuation D Sheet is used to account for more than one (1) project / program.	
IMPORTANT, if box above is checked and no continuation sheets are attached, the application will not be further considered.	

E. Project Goods & Services Requested In the below table, itemize in priority order – starting with the most needed first, ALL items of "Goods" (e.g. equipment, hardware or other durable items) or categories of "Services" which are to be funded in whole or in part from any Grant which may be awarded pursuant to this application.

Enter Project Title from [D] above	Check <input checked="" type="checkbox"/> One	Description	Total Cost	Less any Matching Funds	Grant Amount Requested
1 Rappelling Tower R	<input checked="" type="checkbox"/>	DCH Enterprises, Inc. from Mt. Airy, NC proposes to 'prep the tower' then paint with Epoxy Urethane' from the Shermin Williams Professional product line. Quote is attached.	(a) \$ 23,000.00	(b) \$ -	(a-b) \$ 23,000.00
2	<input type="checkbox"/>		(a) \$ -	(b) \$ -	(a-b) \$ -
3	<input type="checkbox"/>		(a) \$ -	(b) \$ -	(a-b) \$ -
4	<input type="checkbox"/>		(a) \$ -	(b) \$ -	(a-b) \$ -
5	<input type="checkbox"/>		(a) \$ -	(b) \$ -	(a-b) \$ -

← Check IF a Continuation D Sheet is used to account for more than one (1) project / program. IMPORTANT, if box above is checked and no continuation sheets are attached, the application will not be further considered.

E	Enter here the lesser amount of: • Sum of all items (1 thru n) under "Grant Amount Requested" • OR \$50,000 (Grant maximum)	\$ 23,000.00
---	---	--------------

Department of Fire Programs
 Administration
 MAR 04 2016



F. Matching/Cost Share

1	Which statement best describes the matching funds contributions? <i>check <input checked="" type="checkbox"/> one</i>	<input type="checkbox"/> 50% or More	<input type="checkbox"/> Less than 50%	<input checked="" type="checkbox"/> None
---	--	--------------------------------------	--	--

G. ATL Funding

1	What is the amount of the Applicant's FY-2015 Aid to Localities (ATL) allocation from the Fire Programs Fund? <i>check <input checked="" type="checkbox"/> one and complete as necessary</i>	<input type="checkbox"/> \$10,000 or \$20,000 exactly	<input checked="" type="checkbox"/> Other - Enter amount here	\$ 22,310.00
2	Did the Applicant have cash carry forward from FY-2015 into FY-2016 from previous years' Aid to Localities (ATL) allocations? <i>check <input checked="" type="checkbox"/> one and complete as necessary</i>	<input checked="" type="checkbox"/> Yes	<input type="checkbox"/> No	If "Yes", amount of FY-2015 ATL carry forward: \$ 16,000.00

Remarks	Make entries or check <input checked="" type="checkbox"/>	<input checked="" type="checkbox"/> None	Important If the sum (1 to n) of individual "Grant Amount. Requested" in E above exceeded \$50,000, an explanation must be entered here as to how the shortfall would otherwise be made up.

EFT (EDI)

Grant awards are paid as an **Electronic Funds Transfer / EDI** to the current *account-of-record* for the jurisdiction's annual allocation of Aid to Localities (ATL) from the Fire Programs Fund.

Certification:

- To be completed by either:
- County Administrator –or- Executive, City Manager, Town Mayor –or- Administrator; Deputy, or...
 - Other duly authorized official whereby the application is accompanied by a copy of an 'Ordinance' or other such formal instrument clearly granting that party such authority.

This grant application is entered on behalf of the APPLICANT jurisdiction identified above with the knowledge and belief that all representations herein made are true and correct; with the understanding that all grant terms & conditions in-force as of the date of such application are hereby included by reference; with the further understanding that if an award is granted pursuant to this application that the recipient is bound by those same terms & conditions.

	2/29/16
Signature	Date
Keith Barker	City Manager
Printed Name	Title

(All applications must be notarized to be considered – incomplete forms shall be returned.)

State of Virginia }
City / County of Grayson }

On this 29th day of Feb. (month) in 2016 (year), before me, the undersigned a Notary Public for the Commonwealth of Virginia, personally appeared Keith Barker to me known (or to me proved) to be the identical person named herein and having in my presence executed the above, and acknowledged that he executed same as his voluntary act and deed.

My Commission expires: <u>7-31-17</u>	
# <u>7249584</u>	Notary Public
Date	{Seal}

DANA P. WOODEL
Notary Public
Commonwealth of Virginia
7249584
My Commission Expires Jul 31, 2017

Department of Fire Programs
Administration
MAR 04 2016

GALAX FIRE REGIONAL TRAINING GROUNDS

MEMORANDUM OF UNDERSTANDING

Between

Galax Volunteer Fire Department
PO Box 147
300 W. Grayson St
Galax, VA 24333

And

Hillsville Volunteer Fire Department
115 Fulcher St
Hillsville, VA 24343

This Memorandum of Understanding (MOU) sets forth the terms and understanding between the Galax Volunteer Fire Department and Hillsville Volunteer Fire Department regarding the use of the Galax Fire Department Regional Training Grounds.

Background

Partnering with area fire service agencies in training is important for the development of proficient firefighters within our area, both in state certified training and in-house training. Partnering with area fire service agencies also allows mutual aid departments the ability to work together in fire ground training scenarios before they are called upon to work together at actual emergency events.

Purpose

The purpose of this MOU is to establish a clear understanding between the Galax Volunteer Fire Department and any other fire service agency, that we stand ready to provide a suitable fire service training facility for their training needs. Training may be in-house or VDFP formal training. Departments wishing to use the training grounds are asked to make their request known as far in advance of the usage date as possible. Departments wishing to use the training grounds will also be required to fill out a Training Grounds Use Agreement and return to the department before the scheduled training. Contact Mike Ayers at 276-235-9580 or mayers@galaxva.com to schedule a needed date and acquire a Training Grounds Use Agreement. The Galax Volunteer Fire Department nor the City of Galax will be held liable in any way for injuries or damaged equipment incurred at the training grounds during any training whether in-house or VDFP sponsored.

Reporting

The Galax Volunteer Fire Department will solicit MOUs from area departments. The MOUs will be kept on file in the Recruitment and Retention office at the City of Galax Municipal Building.

Funding

The Galax Fire Department Regional Training Grounds are free for any fire agency to use. This MOU in no way reflects a request for funding. Departments utilizing the training grounds may be required to provide training supplies for the props they wish to use. i.e. plywood for the vertical vent prop, furring strips for the forcible entry door prop, or straw and pallets for the live burn building.

Duration

This MOU is at-will and may be modified by mutual consent of authorized officials from Galax Fire and Hillsville Fire. This MOU shall become effective upon signature by the authorized officials from Galax Fire and Hillsville Fire and will remain in effect until modified or terminated by any one of the partners by mutual consent. In the absence of mutual agreement by the authorized officials from Galax Fire and Hillsville Fire, this MOU shall end on March 1, 2018.

Contact Information

Agency Name: Galax Volunteer Fire Department
Agency Representative: Mike Ayers
Position: Captain
Address: PO Box 147 Galax, VA 24333
Telephone: 276-235-9580
E-mail: mayers@galaxva.com

Agency Name: Hillsville Volunteer Fire Department
Agency Representative: Mike Musser
Position: Assistant Chief
Address: 115 Fulcher St Hillsville, VA 24343
Telephone: 276-733-6566
E-mail: Michael.musser@vsp.virginia.gov

Mike Ayers / Galax Fire
(Signature)

Date: 2/19/16

Michael G Musser
(Signature)

Date: 2-20-16

GALAX FIRE REGIONAL TRAINING GROUNDS

MEMORANDUM OF UNDERSTANDING

Between

Galax Volunteer Fire Department
PO Box 147
300 W. Grayson St
Galax, VA 24333

And

Fries Volunteer Fire Department
832 E. Main St
Fries, VA 24330

This Memorandum of Understanding (MOU) sets forth the terms and understanding between the Galax Volunteer Fire Department and Fries Volunteer Fire Department regarding the use of the Galax Fire Department Regional Training Grounds.

Background

Partnering with area fire service agencies in training is important for the development of proficient firefighters within our area, both in state certified training and in-house training. Partnering with area fire service agencies also allows mutual aid departments the ability to work together in fire ground training scenarios before they are called upon to work together at actual emergency events.

Purpose

The purpose of this MOU is to establish a clear understanding between the Galax Volunteer Fire Department and any other fire service agency, that we stand ready to provide a suitable fire service training facility for their training needs. Training may be in-house or VDFP formal training. Departments wishing to use the training grounds are asked to make their request known as far in advance of the usage date as possible. Departments wishing to use the training grounds will also be required to fill out a Training Grounds Use Agreement and return to the department before the scheduled training. Contact Mike Ayers at 276-235-9580 or mayers@galaxva.com to schedule a needed date and acquire a Training Grounds Use Agreement. The Galax Volunteer Fire Department nor the City of Galax will be held liable in any way for injuries or damaged equipment incurred at the training grounds during any training whether in-house or VDFP sponsored.

Reporting

The Galax Volunteer Fire Department will solicit MOUs from area departments. The MOUs will be kept on file in the Recruitment and Retention office at the City of Galax Municipal Building.

Funding

The Galax Fire Department Regional Training Grounds are free for any fire agency to use. This MOU in no way reflects a request for funding. Departments utilizing the training grounds may be required to provide training supplies for the props they wish to use. i.e. plywood for the vertical vent prop, furring strips for the forcible entry door prop, or straw and pallets for the live burn building.

Duration

This MOU is at-will and may be modified by mutual consent of authorized officials from Fries Volunteer Fire Department. This MOU shall become effective upon signature by the authorized officials from Fries Fire and will remain in effect until modified or terminated by any one of the partners by mutual consent. In the absence of mutual agreement by the authorized officials from Fries Volunteer Fire Department, this MOU shall end on March 1, 2018.

Contact Information

Agency Name: Galax Volunteer Fire Department

Agency Representative: Mike Ayers

Position: Captain

Address: PO Box 147 Galax, VA 24333

Telephone: 276-235-9580

E-mail: mayers@galaxva.com

Agency Name: Fries Volunteer Fire Department

Agency Representative: Chad Stanley

Position: Chief

Address: 832 E. Main St Fries, VA 24330

Telephone: 276-233-9922

E-mail: chadstanley@gcps.k12.va.us

Mike Ayers / Galax Fire Dept.
(Signature)

Date: 2/19/16

Chad Stanley / Fries Fire Dept.
(Signature)

Date: 2/21/16

GFD TRAINING GROUNDS USE LOG 2014

<u>DATE</u>	<u>AGENCY</u>	<u>CONTACT</u>	<u>SCHOOL</u>	<u>AGREEMENT SIGNED</u>
1/12/2014 8:00am	Floyd	Wayne Woodyard Fax: 540-921-3150 540-921-2866	FFI	
1/17/2014	Floyd	Wayne Woodyard FFI Practicals-6:00pm-Training Grounds 540-921-2866	FFI	
1/18/2014 8:00am	Radford	David Stilwell 540-230-0992 dstilwell@radford.va.us	FFII	
2/1/2014 8:00am	Elliston	Joe Kingrea 540-392-0413	FF1	Live Burn
3/9/2014	Floyd	David Stilwell 540-230-0992 dstilwell@radford.va.us	FFI Skills only.	
3/15/2014	Giles	Brian Edmonds	FFI Skills only.	
4/13/2014	Floyd	David Stilwell 540-230-0992 dstilwell@radford.va.us	FFI Skills only.	
4/19/2014 8:00am	Fries	Mike Parris 276-233-3303 mparris51@yahoo.com	FFI	Live Burn
4/24/2014 5:00pm	Giles	David Stilwell 540-230-0992 dstilwell@radford.va.us	FFI skills only.	
4/26/2014	Floyd	Wayne Woodyard 540-921-3150 FAX: 540-921-2866	FFI	Live Burn
5/18/2014	Floyd	Wayne Woodyard 540-921-3150 FAX: 540-921-2866	FFII	Live Burn
6/1/2014	Giles	David Stilwell 540-230-0992 dstilwell@radford.va.us	FF1	Practicals
6/28/2014 8:00am	Pulaski	Cliff Phillips 540-616-8875 pfdsgt5@yahoo.com	FF1	Live Burn
6/29/2014	Floyd	David Stilwell 540-230-0992 dstilwell@radford.va.us	FF1	Live Burn

GFD TRAINING GROUNDS USE LOG 2015

DATE	AGENCY	CONTACT	SCHOOL	AGREEMENT SIGNED
1/10/2015	Chilhowie	Robert Taylor 276-759-3711	FF1	Yes
9/12/2015	Meadows of Dan	Michael Harrell 276-692-7530 opiefiremun@gmail.com	FF1	
10/31/2015	Hillsville Fire	Mike Parris 276-233-3303	FF1	
11/1/2015	Galax Fire	Mike Ayers	FF1	
11/8/2015	Fries Fire	Chad Stanley 276-233-9922 chadstanley@gcps.k12.va.us	Mayday	

GALAX VOLUNTEER FIRE DEPARTMENT

2016 REGIONAL FIRE SERVICES TRAINING GRANT

TRAINING PLAN:

1) Per the Regional Fire Services Training Grant Policy, the Galax Volunteer Fire Department is to identify how the jurisdiction meets the basic training standards/elements of Firefighter I and Firefighter II.

-Ladders: Prescribed ladders training for FFI and FFII is accomplished at the Galax Fire Department Regional Training Grounds two story class A burn building. All related skills can be mastered here including carry techniques, setting, heeling, and climbing.

-Ventilation: Prescribed ventilation training for FFI and FFII is accomplished at the Galax Fire Department Regional Training Grounds in two ways. The first is with an adjustable vertical vent prop which allows for flat roof as well as pitched roof practice. Hydraulic ventilation as well as positive/negative pressure ventilation are accomplished in the class A burn building itself using fake smoke.

-Search and Rescue: Prescribed search and rescue training is accomplished by using the class A burn building.

-Hose: Prescribed hose evolutions are accomplished throughout the training facility at various points including active hydrants on property as well as within the class A burn building itself.

-Ropes and Knots: Prescribed ropes and knots activities are mastered on ladders placed on the class A burn building as well as from within the structure.

-SCBA: Prescribed SCBA evolutions are managed both at our firehouse and at the Regional Training Grounds. Initial confidence building and instruction takes place at the firehouse. Students then transition to the training grounds for practice in fake smoke, then the live burn at the appropriate time.

-Salvage and Overhaul: Prescribed skills for salvage and overhaul are practiced both at the Galax firehouse and at the class A burn building at the Regional Training Grounds.

-Sprinklers: Prescribed skills associated with sprinkler usage are mastered utilizing our sprinkler prop attached to the class A burn building at the Regional Training Grounds.

-Forcible Entry: Prescribed skill associated with forcible entry are mastered using our forcible entry door prop located in our prop building adjacent to the class A burn building.

-Portable Fire Extinguishers: Prescribed skills for portable fire extinguishers are accomplished both at the Galax firehouse and on site at the Regional Training Grounds with incipient stage fires.

-Wildland Ground Cover Fires: Galax Fire partners with our local VA Dept of Forestry office to cover wildland ground cover fires and the techniques associated with combating this type of fire. The Regional Training Grounds also offers property suitable for this training.

-Water Supply: Prescribed skills associated with water supply are accomplished both at a training hydrant at the Galax Firehouse as well as two active, live hydrants at the Regional Training Grounds.

2) Memorandums of Understanding for the regional training partnerships are attached. Also, in addition to the departments represented by the attached MOUs, the Galax Fire Department Regional Training Grounds has been utilized by the following agencies over the last 24 months. Floyd County, City of Radford, Elliston, Giles County, Pulaski County, Chilhowie, and Meadows of Dan. Most listed have used the facility multiple times over this 24 month period. A Use Log is attached.

3) The Galax Volunteer Fire Department is requesting funds to maintain an existing four story, steel rappelling tower. This tower is used for VDFP Ropes Classes for our region as well as in-house ropes training/practice by area departments. The rappelling tower also has a standpipe prop built in that is used for training. The rappelling tower has been in place for 30 plus years and has yet to be painted or maintained. Currently, much of the paint has peeled off. The exposed steel is rusting badly. While the tower seems structurally sound, funding is needed for a professional company to sandblast (or other suitable prep method) the tower, then paint the structure with an appropriate, long lasting, exterior paint. Without this maintenance, the tower will have to be replaced eventually.

DCH ENTERPRISES, INC.
P.O. Box 993
Mount Airy, NC 27030
Ph. (336)789-1893
Fax (336)789-1896
www.dchenterprisesinc.com

PROJECT: Rappelling Tower

ATTN: Mike Ayers
Galax Fire Department

We hereby propose to furnish the materials and perform the labor necessary for the following:

Base Price.....\$18,000.00

- **Prep Tower**
- **Paint Tower with DTM (Direct to Metal)**
- **Sherwin Williams Professional product line**

Alternate Price.....\$23,000.00

- **Prep Tower**
- **Paint with Epoxy Urethane**
- **Sherwin Williams Professional product line**

Thank you for the opportunity to provide this proposal.
Please contact me at (336)401-6013 should you have questions or need additional information.

BY: Angela Arnder
DATE: 02/26/16



General Instructions & Notices

- Applicants are directed to "Regional Fire Services Training Facilities Grant Program Policy" as amended for the current funding year which is incorporated by reference to all applications and any subsequent awards. (Such practices document is inclusive of all *terms & conditions*.)
- The filing of an application does not bind the Board to award nor the Department to pay any such grant.
- Incomplete applications and those received after the deadline will not be considered.
(Deadline) → **March 1, 2016 postmarked**
- Completed applications executed by the competent authority will only be accepted directly from jurisdictions not fire departments.
- Timeliness of filing and subsequent receipt by the Agency are solely the applicant's responsibility – all applications must be completed in ink and sent directly to: **VDFP Grants and Local Aid Manager,**
Address → 1005 Technology Park Drive, Glen Allen VA 23059-4500
- All decisions regarding grant awards made by the Board are final; applicants may appeal decisions in writing to the address provided above within 15 business days of the posting of awards.

A. Applicant Information

1. Title of Lead Jurisdiction Making Application (Check <input checked="" type="checkbox"/> only one, then make entry)	<input type="checkbox"/> County of	<input type="checkbox"/> City of	<input type="checkbox"/> Incorporated Town of
	<input checked="" type="checkbox"/>	Hampton	
2. Employer Identification Number (EIN)	[REDACTED]		
3. Principal Point of Contact	(Include salutation, name & title.) Maurice W. Wilson, Assistant Fire Chief		
4. Mailing Address (Include zip code) Identify COUNTY if appropriate	Hampton Division of Fire and Rescue 22 Lincoln Street 6th Floor Hampton, VA 23669		
5. Telephone Number	(757)	727-6580	
6. FAX Number	(757)	727-6094	
7. Internet e-mail address	mwilson@hampton.gov		

B. Additional Parties

	Identify ALL jurisdictions (Not Fire Departments) participating in the proposed project. Attach additional sheets as may be required.
1. Formal Agreement Among Parties	<p>In accordance with Program Policy, multi-jurisdictional regional training partnerships must be documented (e.g. MOA, MOU, etc.) as required supporting documentation to the Application for consideration of Program funding.</p> <p>A copy of the Agreement has been attached to this application. <input type="checkbox"/> Yes <input checked="" type="checkbox"/> No</p> <p><i>If a copy of the Agreement has not been attached as required supporting documentation, this Application will be considered incomplete and funding will not be approved.</i></p>

Department of Fire Programs

FEB 29 2016

Administration



{ Reproduce and complete as many additional blocs as may be necessary for complete disclosure. }

2a. Complete <u>one each</u> for ALL other Parties of Interest	Number <u>2</u> of a total of <u>7</u> parties to proposed project (Count the LEAD Locality as #1, thereby start with #2.)
2b. Title of Jurisdiction <small>(Check <input checked="" type="checkbox"/> only one, then make entry)</small>	<input type="checkbox"/> County of _____ <input checked="" type="checkbox"/> City of <u>Newport News</u> <input type="checkbox"/> Incorporated Town of _____
2c. Employer Identification Number (EIN)	_____
2d. Principal Point of Contact <small>(Include salutation, name & title.)</small>	<u>Robert Alley, Fire Chief</u>
2e. Mailing Address <small>(Include zip code+4)</small> <small>Identify COUNTY if appropriate -</small>	<u>2400 Washington Avenue, 6th Floor Newport News, VA 23607</u>
2f. Telephone Number	(<u>757</u>) <u>926-8404</u>
2g. FAX Number	(<u>757</u>) _____
2h. Internet e-mail address	<u>rballey@nngov.com</u>

Administration

FEB 29 2016

Department of Fire Programs

{ Reproduce and complete as many additional blocs as may be necessary for complete disclosure. }

2a. Complete <u>one each</u> for ALL other Parties of Interest	Number <u>3</u> of a total of <u>7</u> parties to proposed project (Count the LEAD Locality as #1, thereby start with #2.)
2b. Title of Jurisdiction <small>(Check <input checked="" type="checkbox"/> only one, then make entry)</small>	<input checked="" type="checkbox"/> County of <u>James City</u> <input type="checkbox"/> City of _____ <input type="checkbox"/> Incorporated Town of _____
2c. Employer Identification Number (EIN)	_____
2d. Principal Point of Contact <small>(Include salutation, name & title.)</small>	<u>Mr. Ryan Ashe, Fire Chief</u>
2e. Mailing Address <small>(Include zip code+4)</small> <small>Identify COUNTY if appropriate -</small>	<u>5077 John Tyler Highway Williamsburg, VA 23185</u>
2f. Telephone Number	() <u>220-0626</u>
2g. FAX Number	() <u>220-9125</u>
2h. Internet e-mail address	<u>ryan.ashe@jamescitycountyva.gov</u>

{ Reproduce and complete as many additional blocs as may be necessary for complete disclosure. }

2a. Complete <u>one each</u> for ALL other Parties of Interest	Number <u>4</u> of a total of <u>7</u> parties to proposed project (Count the LEAD Locality as #1, thereby start with #2.)
2b. Title of Jurisdiction <small>(Check <input checked="" type="checkbox"/> only one, then make entry)</small>	<input type="checkbox"/> County of _____ <input checked="" type="checkbox"/> City of <u>Williamsburg</u> <input type="checkbox"/> Incorporated Town of _____
2c. Employer Identification Number (EIN)	_____
2d. Principal Point of Contact <small>(Include salutation, name & title.)</small>	<u>Mr. W. Pat Dent, Fire Chief</u>
2e. Mailing Address <small>(Include zip code+4)</small> <small>Identify COUNTY if appropriate -</small>	<u>412 N. Boundary Street Williamsburg, VA 23185</u>
2f. Telephone Number	() <u>220-6220</u>
2g. FAX Number	() <u>220-6229</u>
2h. Internet e-mail address	<u>wdent@williamsburgva.gov</u>



{ Reproduce and complete as many additional blocs as may be necessary for complete disclosure. }

2a. Complete <u>one each</u> for ALL other Parties of Interest	Number 5 of a total of 7 parties to proposed project (Count the LEAD Locality as #1, thereby start with #2.)
2b. Title of Jurisdiction <small>(Check <input checked="" type="checkbox"/> only one, then make entry)</small>	<input checked="" type="checkbox"/> County of York <input type="checkbox"/> City of _____ <input type="checkbox"/> Incorporated Town of _____
2c. Employer Identification Number (EIN)	██████████
2d. Principal Point of Contact	<small>(Include salutation, name & title.)</small> Mr. Stephen Kopczynski, Fire Chief
2e. Mailing Address <small>Identify COUNTY if appropriate</small>	<small>(Include zip code+4)</small> 301 Goodwin Neck Road Yorktown, VA 23692
2f. Telephone Number	(757) 890-3600
2g. FAX Number	(757) 890-3609
2h. Internet e-mail address	kopczyns@yorkcounty.gov

{ Reproduce and complete as many additional blocs as may be necessary for complete disclosure. }

2a. Complete <u>one each</u> for ALL other Parties of Interest	Number 6 of a total of 7 parties to proposed project (Count the LEAD Locality as #1, thereby start with #2.)
2b. Title of Jurisdiction <small>(Check <input checked="" type="checkbox"/> only one, then make entry)</small>	<input type="checkbox"/> County of _____ <input checked="" type="checkbox"/> City of Poquoson <input type="checkbox"/> Incorporated Town of _____
2c. Employer Identification Number (EIN)	██████████
2d. Principal Point of Contact	<small>(Include salutation, name & title.)</small> Mr. Robert Holloway, Fire Chief
2e. Mailing Address <small>Identify COUNTY if appropriate</small>	<small>(Include zip code+4)</small> 830 Poquoson Avenue Poquoson, VA 23662
2f. Telephone Number	() 868-3510
2g. FAX Number	() 868-3514
2h. Internet e-mail address	rholloway@poquoson-va.gov

Administration

FEB 29 2016

Department of Fire Programs

{ Reproduce and complete as many additional blocs as may be necessary for complete disclosure. }

2a. Complete <u>one each</u> for ALL other Parties of Interest	Number 7 of a total of 7 parties to proposed project (Count the LEAD Locality as #1, thereby start with #2.)
2b. Title of Jurisdiction <small>(Check <input checked="" type="checkbox"/> only one, then make entry)</small>	<input type="checkbox"/> County of _____ <input type="checkbox"/> City of U.S. Army Transportation Base - Ft. Eustis <input type="checkbox"/> Incorporated Town of _____
2c. Employer Identification Number (EIN)	N A ██████████
2d. Principal Point of Contact	<small>(Include salutation, name & title.)</small> Mr. Dale Hankins, Fire Chief
2e. Mailing Address <small>Identify COUNTY if appropriate</small>	<small>(Include zip code+4)</small> Building 648 Jackson Avenue Ft Eustis, VA 23604
2f. Telephone Number	() 878-4281
2g. FAX Number	() 878-3592
2h. Internet e-mail address	██████████



C. Previous Applications/Awards

1.	Has the Applicant previously applied for a RFSTF Grant from the Board? - check <input checked="" type="checkbox"/> one	<input checked="" type="checkbox"/> No	<input type="checkbox"/> Yes
2.	Has the Applicant previously received a RFSTF Grant from the Board? - check <input checked="" type="checkbox"/> one	<input checked="" type="checkbox"/> No	<input type="checkbox"/> Yes

D. Project Title(s) and Description(s) Enter a descriptive 'Title' and brief Description for the lead training project and/or program proposed for funding from any Grant which may be awarded pursuant to this application.

1	(Project Title) Fire Training Tower Renovation and Repair	(Description) In November 2015 the Fire Division had an engineering assessment of the fire training tower to identify deficiencies and repair recommendations to ensure the safe use preservation of the tower. The tower had minor and major deficiencies with a total estimated repair cost of \$135,402.03
Which statement best describes the above proposed project and/or program? check <input checked="" type="checkbox"/> one		<input type="checkbox"/> New <input type="checkbox"/> Change to existing <input checked="" type="checkbox"/> Continuing
Which statement best describes how many training programs may benefit from the proposal? check <input checked="" type="checkbox"/> one		<input checked="" type="checkbox"/> Multiple Programs <input type="checkbox"/> Single Program
Describe the impact on training if this Grant is not awarded, or check <input type="checkbox"/> No Significant Impact		
The tower is currently in service. However, without the recommended repairs, the training tower will continue to deteriorate which will ultimately lead to being placed out of service. The tower currently provides accessible, realistic, and effective training for departments throughout the region. A void in realistic training makes it difficult to enhance response capabilities and preparedness for any fire dept.		
<input type="checkbox"/> ← Check <input checked="" type="checkbox"/> IF a Continuation D Sheet is used to account for more than one (1) project / program.		
IMPORTANT, if box above is checked and no continuation sheets are attached, the application will not be further considered.		

E. Project Goods & Services Requested In the below table, itemize in priority order – starting with the most needed first, ALL items of "Goods" (e.g. equipment, hardware or other durable items) or categories of "Services" which are to be funded in whole or in part from any Grant which may be awarded pursuant to this application.

Enter Project Title from [D] above	Check <input type="checkbox"/> One	Description	Total Cost	Less any Matching Funds	Grant Amount Requested
1 Tower's Fire Protection Repair	<input type="checkbox"/> Goods	Removing / replacing sprinkler system and labor	(a)	(b)	(a-b)
	<input checked="" type="checkbox"/> Services		\$ 32,696.40	\$ -	\$ 32,696.40
2 Tower's Plumbing Repair	<input type="checkbox"/> Goods	Removing / replacing plumbing and labor	(a)	(b)	(a-b)
	<input checked="" type="checkbox"/> Services		\$ 22,674.84	\$ -	\$ 22,674.84
3 Tower's Structural Repair	<input type="checkbox"/> Goods	Repair and labor	(a)	(b)	(a-b)
	<input checked="" type="checkbox"/> Services		\$ 63,534.98	\$ -	\$ 63,534.98
4 Tower Electrical Repair	<input type="checkbox"/> Goods	Remove and patch repair	(a)	(b)	(a-b)
	<input checked="" type="checkbox"/> Services		\$ 1,350.16	\$ -	\$ 1,350.16
5 Tower Mechanical Repair	<input type="checkbox"/> Goods	Remove wall louvers/ patch wall labor	(a)	(b)	(a-b)
	<input checked="" type="checkbox"/> Services		\$ 2,836.38	\$ -	\$ 2,836.38
<input type="checkbox"/> ← Check <input checked="" type="checkbox"/> IF a Continuation D Sheet is used to account for more than one (1) project / program.					
IMPORTANT, if box above is checked and no continuation sheets are attached, the application will not be further considered.					

E	Enter here the lesser amount of: • Sum of all items (1 thru n) under "Grant Amount Requested" • OR \$50,000 (Grant maximum)	\$50,000
---	--	-----------------

Department of Fire Programs
 Administration
 FEB 29 2016



F. Matching/Cost Share

1	Which statement best describes the matching funds contributions? <i>check <input checked="" type="checkbox"/> one</i>	<input checked="" type="checkbox"/> 50% or More	<input type="checkbox"/> Less than 50%	<input type="checkbox"/> None
---	--	---	--	-------------------------------

G. ATL Funding

1	What is the amount of the Applicant's FY-2015 Aid to Localities (ATL) allocation from the Fire Programs Fund? <i>check <input checked="" type="checkbox"/> one and complete as necessary</i>	<input type="checkbox"/> \$10,000 or \$20,000 exactly	<input checked="" type="checkbox"/> Other - Enter amount here	\$ 435,416.00
2	Did the Applicant have cash carry forward from FY-2015 into FY-2016 from previous years' Aid to Localities (ATL) allocations? <i>check <input checked="" type="checkbox"/> one and complete as necessary</i>	<input checked="" type="checkbox"/> Yes	<input type="checkbox"/> No	If "Yes", amount of FY-2015 ATL carry forward: \$ 52,519.00

Remarks	Make entries or check <input checked="" type="checkbox"/> None	Important [Ⓞ] If the sum (1 to n) of individual "Grant Amount. Requested" in E above exceeded \$50,000, an explanation must be entered here as to how the shortfall would otherwise be made up.
	The total project cost as quoted is \$135,402.03 (\$123,092.76 plus 10% contingency of \$12,309.28)	
	If awarded, the City of Hampton will be responsible for \$85,402.03 of the project cost after the grant award.	
	Please see the attached justification statement for additional details relative to the application for the grant award.	

EFT (EDI)

Grant awards are paid as an **Electronic Funds Transfer / EDI** to the current *account-of-record* for the jurisdiction's annual allocation of Aid to Localities (ATL) from the Fire Programs Fund.

Certification:

- To be completed by either:
- County Administrator –or- Executive, City Manager, Town Mayor –or- Administrator; Deputy, or...
 - Other duly authorized official whereby the application is accompanied by a copy of an 'Ordinance' or other such formal instrument clearly granting that party such authority.

This grant application is entered on behalf of the APPLICANT jurisdiction identified above with the knowledge and belief that all representations herein made are true and correct; with the understanding that all grant terms & conditions in-force as of the date of such application are hereby included by reference; with the further understanding that if an award is granted pursuant to this application that the recipient is bound by those same terms & conditions.

Mary Bunting
Signature

2/25/16
Date

Mary Bunting
Printed Name

City Manager
Title

(All applications **must** be notarized to be considered – incomplete forms shall be returned.)

State of Virginia

City / County of Hampton

On this 25th day of February (month) in 2016 (year), before me, the undersigned a Notary Public for the Commonwealth of Virginia, personally appeared Mary B. Bunting to me known (or to me proved) to be the identical person named herein and having in my presence executed the above, and acknowledged that he executed same as his voluntary act and deed.

My Commission expires:

July 31, 2019
Date

Corina S. Hodges
Notary Public

**CITY OF HAMPTON
OFFICE OF THE CITY ATTORNEY**

Approved as to legal form and sufficiency

Date: 2/24/16

[Signature]
Attorney

Department of Fire Programs
Administration
FEB 29 2016

2016 RFSTF

Renovation and Repair of Training Tower (City of Hampton)

The City of Hampton is located in Southeastern Virginia within the region known as Hampton Roads. The City of Hampton covers approximately 54 square miles of land and 17 square miles of water, with a 2013 Census population of 136,699. The median age is 34 years old and the median income of households was \$49,815. The largest employers within the city are Langley Air Force Base, Alcoa Howmet, National Aeronautics and Space Administration (NASA) Langley Research Center, Hampton University, Hampton City Schools, Thomas Nelson Community College, the City of Hampton, Sentara CarePlex, the Hampton Veterans Administration Medical Center and Sprint. The city's annual Operating Budget is \$446,790,314, funded through various taxes, fees, and funds.

The Hampton Division of Fire and Rescue (HDFR) is a combination all hazards fire department consisting of 284 uniformed permanent full time members, 13 permanent full time civilian members, 100 volunteer members and a compliment of 38 part time uniform members, instructors, inspectors, and civilians operating from 11 stations and 2 administrative/ support areas. The annual Operating Budget for the Division for FY 16 is \$19,346,332. The Division operates three shifts, with 87 members assigned to each shift, operating with a minimum per shift staffing level of 65. Operations are divided between two battalions, each of which is managed daily by a Battalion Chief. The Division operates five Engines, two Squads, five Ladders, nine Advanced Life Support (ALS) transport medic units, two Battalion Chiefs, and two EMS Field Supervisors daily. Minimum staffing is four members for all ladders, Squad 10 (TRT), and single engine companies per SOP #20-2-1 Minimum Staffing. All other apparatus minimum staffing is three members except for the Battalion Chiefs and EMS Field Supervisors with a minimum

staffing of one each. A floating lieutenant is assigned to each battalion on each shift for a total of six floating lieutenants. Staffing per NFPA 1710 is met with the EMS Supervisor or second fire apparatus on scene for those responses requiring an effective response force. In addition to Fire and Emergency Medical Services, the Division also provides Technical Rescue, Hazardous Materials, and Marine Incident Response. The Division has averaged 23,766 calls for service over the last 5 years, with the largest portion of calls being EMS, followed by general emergency, and then fire calls.

The Community Risk Reduction Section consists of the Professional Standards Branch (PSB) and the Fire Prevention Branch. The PSB coordinates all Fire Division recruitment and training, both fire and EMS, and is the keystone to the preparation of service-ready members. The PSB is led by a battalion chief and is supported by two lieutenants, two medic/firefighter instructors, a recruitment, retention, and training support specialist, and a civilian assistant. The staff is responsible for training the Division's incumbent volunteer and career members, as well as recruits and volunteers from the Division and other regional jurisdictions. The PSB's training grounds consists of a two-story classroom training facility, also housing other Division sections, branches, and groups, and an outdoor training facility located behind Fire Station 9. The training grounds located at Fire Station 9 include a five-story training tower, a confined space training building, a roof ventilation training prop, a vehicle fire training prop, and various other constructed apparatus for training purposes. All of the aforementioned props and facilities are part of a regional training agreement and are available for use by all other regional jurisdictions.

The Hampton Division of Fire and Rescue is requesting funding for renovation and repairs of one of the region's critical training assets. The Division's five-story training tower, located on the training grounds at Hampton Station 9 (1590 Briarfield Road, Hampton, VA

23669), is part of the training required by the Tidewater Regional Fire Academy (TRFA) and completion of the Virginia Department of Fire Programs' (VDFP) Firefighter (FF) I and II curriculum as well as other VDFP certificate courses. TRFA is a regional partnership among the City of Newport News, City of Hampton, York County, James City County, City of Poquoson, City of Williamsburg, and the U.S. Army Transportation Center, to provide basic firefighter training to career and volunteers firefighters. The TRFA curriculum and VDFP certificate course requires the use of Hampton's training tower to complete evolutions associated with high-rise hazards, standpipes, rope rescue, ladders, and other fire-related training.

The Fire Training Tower is a five-story concrete structure, with a staircase on one side, which has doors opening to small open rooms at each floor. The open rooms and roof area are surrounded by a hand rail for fall protection. The stairwell has a dry standpipe running up the height of the building, which can be charged through a fire department connection located on the exterior of the building. This standpipe supplies individual sprinkler heads located in each of the open room areas, as well as hose connections at each floor. However, the tower has slowly deteriorated over time through use and weather-related influences despite periodic efforts to address deficiencies as they arise. The repairs recommended by a certified engineering contractor are numerous and are associated with a large cost to the city.

In November 2015, The Fire Division contracted with Coastal Engineering to perform a facilities assessment by identifying deficiencies and providing repair recommendations on the training tower to ensure the safe use and preservation of the structure. This assessment consisted of five major building subcomponents: the mechanical system, the electrical system, the plumbing system, the fire protection system, and the structural system. All five of these subcomponents had minor to major deficiencies with a total repair cost estimate at \$135,402.03.

The plumbing and fire protection systems were observed to have the major deficiencies. Both of these systems were recommended to be replaced due to the various signs of deterioration and poor conditions. The structural system had minor deficiencies but was in good condition. No signs of distress, deflection, or structural deformations were noted. A detailed assessment and quote was provided by Coastal Engineering (attached).

The Fire Training Tower is currently in service. However, without the recommended repairs, the training tower will continue to deteriorate which will ultimately lead to it being placed out of service, potentially affecting the training of hundreds of recruits, volunteers, and incumbents across the region. The Tower currently provides accessible, realistic, and effective training for departments throughout the region. The high cost of constructing and maintaining such a training implement, all funded by the City of Hampton, makes it difficult for individual departments to build and sustain quality training for their personnel. The ability to fund and maintain state-of-the-art training facilities is beyond most, if not all, departments in the Commonwealth, and the lack of access to such facilities can increase the risk to uniform and civilian personnel alike. A void in realistic training also makes it difficult to enhance response capabilities and preparedness for all Peninsula regional fire agencies.

Exhibit 1: Fire Training Tower quote to provide engineering assessment



August 24, 2015

Mr. Maurice Wilson, CFO, CFI
Assistant Chief- Fire Marshal
Hampton Division of Fire and Rescue
Hampton, Virginia 23669

REF: Facilities Assessment for Hampton Fire Training Tower

Dear Maurice:

Coastal Engineering is pleased to provide this fee proposal to perform a facilities assessment for the Hampton Fire Departments training tower. Based on our conversations and the photos you forwarded to our office we understand that the purpose of this analysis is to inspect the facility for structural and physical issues as related to the structure and associated piping systems. We will perform a site survey of the facility to assess the existing conditions. The findings of our site assessment along with our recommendations will be presented in report format, along with an estimated construction cost for the recommended repairs. Our assessment will be based on visual nondestructive site investigation and does not include testing of system components or operation.

Our assessment will include, site investigation, preparation of the report, and generation of a construction cost estimate. Our fee does not include any design work associated with the results of the study or any construction administrative services. Our fee for the above design services is as follows:

Facilities Assessment	\$1,920 (one thousand nine hundred twenty dollars)
-----------------------	--

Additional authorized services will be billed at \$90.00 (ninety dollars) per hour on an as needed basis. Our fee includes the production of interim progress and original final design documents. Reproduction bid sets is not included.

If you have any questions regarding this proposal, please do not hesitate to call our office.
If this fee is acceptable, please sign below and return to our office as soon as possible.

Sincerely,

COASTAL ENGINEERING

Richard M. Klein, P.E.
President

Signature of Acceptance

Date

COASTAL ENGINEERING, PLLC 2406 NO. 2 PRINCESS ANNE ROAD VIRGINIA BEACH VIRGINIA 23456 757-563-9027 FAX 757-563-9028

NOTE: The Hampton Division of Fire and Rescue paid this fee to acquire the detailed assessment below.

Facility Assessment for Hampton Fire Training Tower

Hampton, Virginia

November 20, 2015

Prepared by:



2406 Princess Anne Road, Suite 200
Virginia Beach, Virginia 23456
Phone: 757-563-9027
Fax: 757-563-9028
www.coastal-eng.com



Table of Contents

General Building Description 2

Methodology of Analysis 3

Mechanical System Analysis 3

 Observations 3

 Recommendations: 3

Electrical System Analysis 5

 Observations 5

 Recommendations: 5

Plumbing System Analysis 8

 Observations 8

 Recommendations: 8

Fire Protection System Analysis 11

 Observations 11

 Recommendations: 11

Structural System Analysis 14

 Observations 14

 Recommendations: 15

General Building Description

The Hampton Fire Training Tower is located behind Hampton Fire Station #9 (Briarfield) located at 1590 Briarfield Road in Hampton, Virginia. The building serves as a training facility for the city's fire fighters. It is used for the simulation of real life situations involving stairwell ascent and descent under conditions which can be enhanced by simulated smoke and sprinkler discharge. The building has an active stand pipe and sprinkler system allowing the training of hose operations in multi floor facilities and the exterior is also used for ladder operations.

The Fire Training Tower is a four story concrete structure, with a staircase on one side which has doors opening to small open rooms at each floor. The exception to this layout is the first level which has an enclosed storage in lieu of the open rooms. The open rooms and roof area are surrounded by a hand rail for fall protection. The stairwell has a dry standpipe running up the height of the building, which can be energized through a wall fire department connection located on the exterior of the building. This stand pipe supplies individual sprinkler heads located in each of the open room areas, as well as hose connections at each floor. Each of the open rooms has a floor drain which connects to a riser that runs down to below grade and dumps into the adjacent storm water drop inlet.

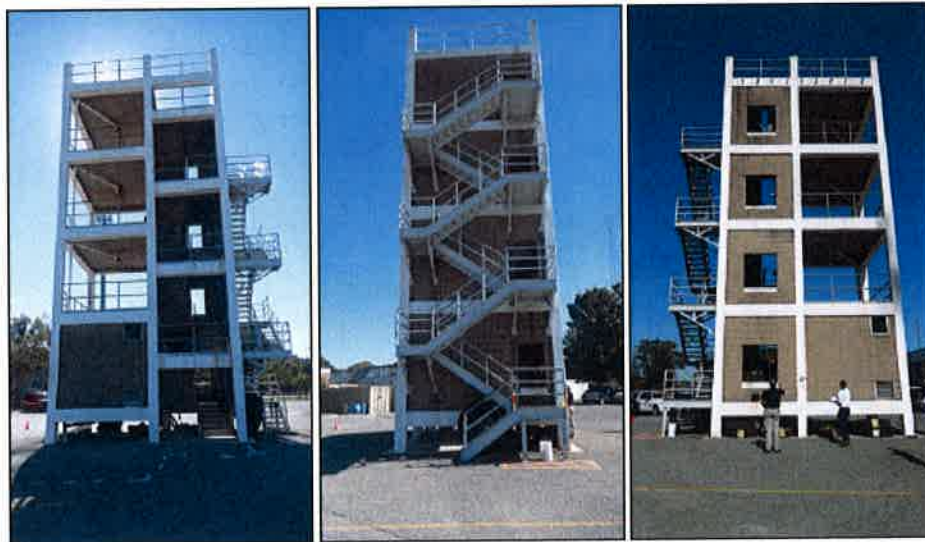



Methodology of Analysis

The City of Hampton contracted Coastal Engineering to perform a facilities assessment of the existing Fire Training Tower to identify deficiencies and repair recommendations. This assessment included the structural and finish components of the building. For the structural analysis portion, Coastal Engineering retained the services for McPherson Design Group P.C. An onsite investigation was performed which consisted of a visual non-destructive investigation to review the condition of the building. Original design documents were not available for the building and materials testing and nor the determination of the load capacities of the existing structural components were not part of this analysis.

The building consisted of four major building subcomponents; the Mechanical System, the Electrical System, The Plumbing System, the Fire Protection System, and the Structural System. The observations and results of this analysis are listed below by each individual system:

Mechanical System Analysis

Observations

The only mechanical systems associated with the building are the three wall louvers which serve first level storage room. It appears that there were originally four wall louvers, two mounted high on opposing walls and two mounted low on opposing walls, however one of the high louvers has been replaced by a window. The remaining three louvers have been blocked off with plywood and are no longer operational. The lentic plates above two of the louvers are showing signs of rust and deterioration.

Recommendations:

Remove the three non-active louvers and repair the structure to match existing. This will prevent further deterioration of the lentic and wall.

Photos:



Photo 1 Remove Three Non-Active Louvers



Photo 2 Blocked Louver



Photo 3 Blocked Louver



Electrical System Analysis

Observations

The buildings electrical system consisted of a single circuit feeding underground from the adjacent building. The circuit comes up below the building in metal conduit and runs above grade to the opposite side where it enters into one of the structural columns. The above grade conduit is badly deteriorated with wires lying exposed in several places. In addition the conduit is badly deteriorating where it enters the structural column which could cause future deterioration of the column and its finishes. The conduit and circuit feed up the column to the first level storage room where it feeds a single light fixture through a wall switch. From the switch an additional conduit and circuit feed through the exterior wall to a junction box on the structural column where it continues to the roof level where there is a GFI receptacle located in a weather tight cover on the structural column. The light and circuit were not active at the time of our investigation and fire department personnel indicated that it was not needed.

Recommendations:

Remove the circuit in its entirety back to the panel in the adjacent building and label the breaker as a spare. Remove the exposed conduit to within the slab on grade and patch the concrete to match existing as well as removing the conduit from the panel in the existing building to below the slab and patch the slab to match existing. Remove all exposed conduit in the structural and storage room including the lighting fixture and receptacle and patch the structure to match existing to prevent further deterioration of the building components.

Photos:



Photo 1 Remove Exposed Conduit



Photo 2 Remove Exposed Conduit



Photo 3 Remove Receptacle



Photo 4 Remove Receptacle



Plumbing System Analysis

Observations

There is no active water source to the building other than the dry stand pipe and sprinkler system which is covered in the fire protection section of this report. Each of the four floors including the roof level has a floor drain located in the center of the open room area. The floor drains have 8" x 8" grate and empties into a 4" vertical riser with a vent through the top level down to below grade where it runs underground for approximately 20 feet and dumps into the side of a large area drop inlet. Each of the drains empty through a 4" P-trap, these traps are all in various stages of disrepair either from rusting through, freeze damage, to the one serving the first level storage room being completely gone. The general condition of the entire drainage piping system is very poor and the pipes passing through the floor slabs are showing even greater signs of deterioration.

Recommendations:

Water which remains in the P-traps is causing the greatest problem with the drainage pipe failures. However the entire drainage piping system is experiencing various signs of deterioration, therefore all of the drainage piping including the drains should be replaced with all through floor slab penetration being repaired and sealed for the new pipe. The existing area where the drain goes below grade should be excavated and repaired as required for the installation of a new drop inlet which can feed through the existing below grade pipe to the existing drop inlet. By using a drop inlet an air gap can be provided from the new drain riser which would offset the need to add traps to the floor drains which will greatly decrease the deterioration of the piping system. With the installation of the new piping system the existing hangers and anchors should be removed and the concrete patched to match existing to reduce future deterioration to the slab. New hangers and anchors would be installed in slightly different locations.

Photos:



Photo 1 Sanitary Piping Missing



Photo 2 Deteriorated P-Trap



Photo 3 Deteriorated Sanitary Piping



Photo 4 Deteriorated P-Trap



Fire Protection System Analysis

Observations

The fire protection system utilizes a dry pipe riser feed from a wall mounted fire department connection, the riser runs up in the stairway area of the building through all floors with the exception of the roof. Each floor has a hose connection and valve and a branch to the sprinkler head located in the open room area, the first floor storage room does not have a sprinkler head. Piping for the sprinkler heads is in poor condition and has failed and been replaced in some cases. In several areas the anchors and supports for the sprinkler pipe have deteriorated to the point of failure.

The stand pipe system has had several valves replaced over the course of time and has broken valves in it due to freezing. A drain valve has been added to the stand pipe, however there are many low places in the system that do not allow for gravity drainage. The through floor pipe clamps are showing signs of deterioration which is starting to damage the surrounding slab.

Recommendations:

The entire dry stand pipe system should be replaced and designed to allow for proper gravity drainage which would reduce freezing and deterioration problems. Consideration should be given to the use of schedule 40 or possibly schedule 80 pipe which will last longer in the given exterior environment. With the installation of the new stand and sprinkler piping system the existing hangers and anchors should be removed and the concrete patched to match existing to reduce future deterioration to the slab. New hangers and anchors would be installed in slightly different locations. The new standpipe should have a easy to operate low point drain which would serve the entire system.

Photos:



Photo 1 Deteriorated Piping



Photo 2 Deteriorated Piping



Photo 3 Deteriorated Piping



Photo 4 Deteriorated Piping



Photo 5 Deteriorated Piping



Photo 6 Existing Hose Connection

Structural System Analysis

Observations

On October 21, 2015, we performed a structural condition assessment of the Fire Training Tower located behind Fire Station 9 at 1590 Briarfield Road. We performed a general assessment of the visible structural components. We did not perform any material testing or determine load capacities of any of the existing structural components. In addition, there were no available as-built construction documents for our use.

The structure is a five-story predominately open cast-in-place concrete framed tower with a base dimension approximately twenty (20) feet by seventeen (17) feet (See **Photo #1.**) There is a concrete stairway within the building footprint and also steel framed stair on the exterior north side. The steel stair may have been added several years after the construction of the tower. The infill walls between the floor levels are composed of concrete masonry units (CMU) back up wall with ribbed face CMU veneer. At the wall openings, there is a precast CMU lintel supporting the backup wall and a steel angle supporting the veneer.

It is our understanding the structure is at least 30 years of age and is primarily used for multi-story fire training simulations. The building is only exposed to water and is not exposed to actual fires. The structure is also used for ladder and rappelling exercises.

The overall structure appears to be sound and in good condition. We did not see any indications of distress such as excessive deflections or structural deformations. There are isolated areas of concrete spalls partially exposing concrete reinforcing steel throughout the structure. The depth of the spalls did not exceed half an inch and the length of the exposed reinforcing steel did not exceed four inches. (See **Photo #2.**) The exposed reinforcing only has only surface rust without any loss of section. The steel angle lintels supporting the veneer at the window opening have a layer of surface rust. We could not determine if these had been previously galvanized or painted.

The concrete stairs were originally constructed with aluminum non-slip treads inset at the tread nosing. Most of these treads are either loose, missing, or in some cases the concrete has spalled exposing the nosing reinforcing steel (See **Photos #3, 4, & 5**). According to the fire department, the remaining aluminum treads are no longer non-slip and are creating a hazard. It is our opinion water is being trapped between



the aluminum tread and concrete. The treads are breaking due to temperature changes such as freeze/thaw cycles.

As for the railings, we only noted one railing post connection which was displaced due to spalled concrete (See **Photo #6**). This occurred between the fourth and fifth level. In addition, there is a railing section at the top level showing indications of wear due to the use of rescue ropes. The paint has completely worn down and the steel is corroding and beginning to lose steel material. This occurred on mid and top horizontal rail (See **Photo #7**).

Recommendations:

- Spalled Concrete
 - Remove all dirt, grease, and loose concrete debris.
 - Remove surface rust of reinforcing steel.
 - Apply concrete patching mortar such as SikaQuick VOH in accordance to manufacturers recommendations (see attached product information)
- Remove surface rust of steel angle lintels and repaint with a corrosion inhibiting paint.
- Stair treads
 - At missing threads, apply patching mortar such as Sika32LoMod Gel to fill in original aluminum steel tread.
 - As for the treads with spalled concrete and exposed reinforcing steel, all loose concrete, dirt, debris, and corrosion should be removed prior to patching with the repair mortar.
 - Install a new full depth aluminum tread such as Grit Strip Metal Tread by American Tread Company. The new tread should be adhered to clean concrete surface with a solvent based adhesive and then anchored with countersunk Tapcon screws. The adhesive will prevent water being entrapped between the concrete and new tread.
- Stair rail post connection
 - Remove anchors and repair spalled concrete as previously noted.
 - Replace anchors with epoxy adhesive anchors of the same size and depth.
 - Epoxy anchors should be Hilti HY200 anchor system or approved equivalent.
- Worn railing
 - Remove and replace with same diameter and thickness. The new sections shall be bulky welded, grind smooth, and repainted with an exterior grade, corrosion inhibiting paint.



It was our pleasure to provide you with our services. If you have further questions or require our services in the future, please do not hesitate to contact our office.

Sincerely,

MCPHERSON DESIGN GROUP, P.C.

Erol J. Aydar, P.E.
EJA/lap

Photos:



Photo 1 East Elevation



Photo 2 Typical Concrete Spall



Photo 3 Exposed Tread Nosing Bar



Photo 4 Exposed Tread Nosing Bar



Photo 5 Missing Aluminum Non-Slip Tread



Photo 6 Displaced Hand Rail Connection



Photo 7 Worn/Damaged Hand Rail

QUAN.	CSI NUMBER	DESCRIPTION	U.M.	UNIT COST			EXTENDED COST			
				MAT.	LABOR	EQUIP.	MAT.	LABOR	EQUIP.	
		Mechanical Cost Estimate								
3		Demo Existing Wall Louvers	ea	\$ 250.00	\$ 125.00		\$ 750.00	\$ 375.00	\$ -	\$ -
3		Patch wall	ea		\$ 250.00			\$ 750.00	\$ -	\$ -
		subtotal					\$ 750.00	\$ 1,125.00	\$ -	\$ -

DESCRIPTION	U.M.	%			MULTIPLIER		
		MAT.	LABOR	EQUIP.	MAT.	LABOR	EQUIP.
PRIME WORK:							
TAX/INSURANCE		7.0%	26.0%	7.0%	1.070	1.260	1.070
OVERHEAD		15.0%	15.0%	15.0%	1.150	1.150	1.150
PROFIT		10.0%	10.0%	10.0%	1.100	1.100	1.100
BOND		1.0%	1.0%	1.0%	1.010	1.010	1.010
COMPOSITE MULTIPLIER FOR PRIME WORK ->					1.367	1.610	1.367
SUB-CONTRACT WORK:							
TAX/INSURANCE		7.0%	26.0%	7.0%	1.070	1.260	1.070
OVERHEAD		15.0%	15.0%	15.0%	1.150	1.150	1.150
PROFIT		10.0%	10.0%	10.0%	1.100	1.100	1.100
PRIME OVERHEAD		5.0%	5.0%	5.0%	1.050	1.050	1.050
PRIME PROFIT		5.0%	5.0%	5.0%	1.050	1.050	1.050
BOND		1.0%	1.0%	1.0%	1.010	1.010	1.010
COMPOSITE MULTIPLIER FOR SUB-CONTRACTOR WORK ->					1.507	1.775	1.507



General Instructions & Notices

- Applicants are directed to "**Regional Fire Services Training Facilities Grant Program Policy**" as amended for the current funding year which is incorporated by reference to all applications and any subsequent awards. (Such practices document is inclusive of all *terms & conditions*.)
- The filing of an application does not bind the Board to award nor the Department to pay any such grant.
- Incomplete applications and those received after the deadline will not be considered.
(Deadline) → **March 1, 2016 postmarked**
- Completed applications executed by the competent authority will only be accepted directly from jurisdictions not fire departments.
- Timeliness of filing and subsequent receipt by the Agency are solely the applicant's responsibility – all applications must be completed in ink and sent directly to: **VDFP Grants and Local Aid Manager,**
Address → 1005 Technology Park Drive, Glen Allen VA 23059-4500
- All decisions regarding grant awards made by the Board are final; applicants may appeal decisions in writing to the address provided above within 15 business days of the posting of awards.

A. Applicant Information

1. Title of Lead Jurisdiction Making Application (Check <input checked="" type="checkbox"/> only one, then make entry)	<input type="checkbox"/> County of	<input type="checkbox"/> City of	<input type="checkbox"/> Incorporated Town of
	<input checked="" type="checkbox"/>	Harrisonburg	
2. Employer Identification Number (EIN)	[REDACTED]		
3. Principal Point of Contact	(Include salutation, name & title.) Michael Brady, Deputy Fire Chief		
4. Mailing Address (Include zip code) Identify COUNTY if appropriate	101 North Main Street Third Floor Harrisonburg, VA 22802		
5. Telephone Number	(540)	432-7703	
6. FAX Number	(540)	432-7780	
7. Internet e-mail address	mike.brady@harrisonburgva.gov		

B. Additional Parties

	Identify ALL jurisdictions (Not Fire Departments) participating in the proposed project. Attach additional sheets as may be required.
1. Formal Agreement Among Parties	<p>In accordance with Program Policy, multi-jurisdictional regional training partnerships must be documented (e.g. MOA, MOU, etc.) as required supporting documentation to the Application for consideration of Program funding.</p> <p>A copy of the Agreement has been attached to this application. <input checked="" type="checkbox"/> Yes <input type="checkbox"/> No</p> <p><i>If a copy of the Agreement has not been attached as required supporting documentation, this Application will be considered incomplete and funding will not be approved.</i></p>

Department of Fire Programs

MAR 04 2016

Administration



{ Reproduce and complete as many additional blocs as may be necessary for complete disclosure. }

2a. Complete <u>one</u> each for ALL other Parties of Interest	Number <u>1</u> of a total of <u>3</u> parties to proposed project <small>(Count the LEAD Locality as #1, thereby start with #2.)</small>									
2b. Title of Jurisdiction <small>(Check <input checked="" type="checkbox"/> only one, then make entry)</small>	<table border="1"> <tr> <td><input type="checkbox"/></td> <td>County of</td> <td></td> </tr> <tr> <td><input checked="" type="checkbox"/></td> <td>City of</td> <td>Harrisonburg</td> </tr> <tr> <td><input type="checkbox"/></td> <td>Incorporated Town of</td> <td></td> </tr> </table>	<input type="checkbox"/>	County of		<input checked="" type="checkbox"/>	City of	Harrisonburg	<input type="checkbox"/>	Incorporated Town of	
<input type="checkbox"/>	County of									
<input checked="" type="checkbox"/>	City of	Harrisonburg								
<input type="checkbox"/>	Incorporated Town of									
2c. Employer Identification Number (EIN)	[REDACTED]									
2d. Principal Point of Contact	<small>(Include salutation, name & title.)</small> Michael Brady, Deputy Fire Chief									
2e. Mailing Address <small>Identify COUNTY if appropriate</small>	<small>(Include zip code+4)</small> 101 North Main Street Third Floor Harrisonburg, VA 22802									
2f. Telephone Number	(540) 432-7703									
2g. FAX Number	(540) 432-7780									
2h. Internet e-mail address	mike.brady@harrisonburgva.gov									

{ Reproduce and complete as many additional blocs as may be necessary for complete disclosure. }

2a. Complete <u>one</u> each for ALL other Parties of Interest	Number <u>2</u> of a total of <u>3</u> parties to proposed project <small>(Count the LEAD Locality as #1, thereby start with #2.)</small>									
2b. Title of Jurisdiction <small>(Check <input checked="" type="checkbox"/> only one, then make entry)</small>	<table border="1"> <tr> <td><input checked="" type="checkbox"/></td> <td>County of</td> <td>Rockingham</td> </tr> <tr> <td><input type="checkbox"/></td> <td>City of</td> <td></td> </tr> <tr> <td><input type="checkbox"/></td> <td>Incorporated Town of</td> <td></td> </tr> </table>	<input checked="" type="checkbox"/>	County of	Rockingham	<input type="checkbox"/>	City of		<input type="checkbox"/>	Incorporated Town of	
<input checked="" type="checkbox"/>	County of	Rockingham								
<input type="checkbox"/>	City of									
<input type="checkbox"/>	Incorporated Town of									
2c. Employer Identification Number (EIN)	[REDACTED]									
2d. Principal Point of Contact	<small>(Include salutation, name & title.)</small> Jeremy Holloway, Fire Chief									
2e. Mailing Address <small>Identify COUNTY if appropriate</small>	<small>(Include zip code+4)</small> 20 East Gay Street Harrisonburg, VA 22802 Rockingham									
2f. Telephone Number	(540) 564-3175									
2g. FAX Number	(540) 564-1823									
2h. Internet e-mail address	jholloway@rockinghamcountyva.gov									

{ Reproduce and complete as many additional blocs as may be necessary for complete disclosure. }

2a. Complete <u>one</u> each for ALL other Parties of Interest	Number <u>3</u> of a total of <u>3</u> parties to proposed project <small>(Count the LEAD Locality as #1, thereby start with #2.)</small>									
2b. Title of Jurisdiction <small>(Check <input checked="" type="checkbox"/> only one, then make entry)</small>	<table border="1"> <tr> <td><input type="checkbox"/></td> <td>County of</td> <td></td> </tr> <tr> <td><input checked="" type="checkbox"/></td> <td>City of</td> <td>Harrisonburg-Massanutten Technical Center</td> </tr> <tr> <td><input type="checkbox"/></td> <td>Incorporated Town of</td> <td></td> </tr> </table>	<input type="checkbox"/>	County of		<input checked="" type="checkbox"/>	City of	Harrisonburg-Massanutten Technical Center	<input type="checkbox"/>	Incorporated Town of	
<input type="checkbox"/>	County of									
<input checked="" type="checkbox"/>	City of	Harrisonburg-Massanutten Technical Center								
<input type="checkbox"/>	Incorporated Town of									
2c. Employer Identification Number (EIN)	[REDACTED]									
2d. Principal Point of Contact	<small>(Include salutation, name & title.)</small> Jolene Powell-Lieutenant									
2e. Mailing Address <small>Identify COUNTY if appropriate</small>	<small>(Include zip code+4)</small> 325 Pleasant Valley Road Harrisonburg, VA 222801									
2f. Telephone Number	(540) 434-5961									
2g. FAX Number	()									
2h. Internet e-mail address	jolene.powell@mtcva.com									



C. Previous Applications/Awards

1.	Has the Applicant previously applied for a RFSTF Grant from the Board? - check <input checked="" type="checkbox"/> one	<input checked="" type="checkbox"/> No	<input type="checkbox"/> Yes
2.	Has the Applicant previously received a RFSTF Grant from the Board? - check <input checked="" type="checkbox"/> one	<input checked="" type="checkbox"/> No	<input type="checkbox"/> Yes

D. Project Title(s) and Description(s)

Enter a descriptive 'Title' and brief Description for the lead training project ^{and} / or program proposed for funding from any Grant which may be awarded pursuant to this application.

(Project Title)	(Description)
1 Forcible Entry Project	The project will better equip the Harrisonburg Fire Department, Rockingham County Department of Fire and Rescue, and the Fire/Rescue Program at Massanutten Technical Center to train in basic and advanced forcible entry, RIC, and self-rescue techniques.
Which statement best describes the above proposed project and/or program? check <input checked="" type="checkbox"/> one	<input type="checkbox"/> New <input checked="" type="checkbox"/> Change to existing <input type="checkbox"/> Continuing
Which statement best describes how many training programs may benefit from the proposal? check <input checked="" type="checkbox"/> one	<input checked="" type="checkbox"/> Multiple Programs <input type="checkbox"/> Single Program
Describe the impact on training if this Grant is not awarded, or check <input checked="" type="checkbox"/> No Significant Impact	
Currently we are using an old forcible entry door that allows single use training. The new props will provide for a variety of levels of training for both new and current firefighters and officers. These props will enhance the Firefighter I and II programs offered in Rockingham County and at Massanutten Technical Center by offering them more realistic training. The props will also enhance the daily training for the	
<input checked="" type="checkbox"/> ← Check <input checked="" type="checkbox"/> IF a Continuation D Sheet is used to account for more than one (1) project / program. IMPORTANT, if box above is checked and no continuation sheets are attached, the application will not be further considered.	

Administration

MAR 04 2016

Department of Fire Programs

E. Project Goods & Services Requested

In the below table, itemize in priority order – starting with the most needed first, ALL items of "Goods" (e.g. equipment, hardware or other durable items) or categories of "Services" which are to be funded in whole or in part from any Grant which may be awarded pursuant to this application.

Enter Project Title from [D] above	Check <input checked="" type="checkbox"/> One	Description	Total Cost	Less any Matching Funds	Grant Amount Requested
1	<input checked="" type="checkbox"/> Goods <input type="checkbox"/> Services	Second Generation Forcible Entry Door Simulator	(a)	(b)	(a-b)
			\$ 7,000.00	\$ -	\$ 7,000.00
2	<input checked="" type="checkbox"/> Goods <input type="checkbox"/> Services	High Security Padlock Simulator	(a)	(b)	(a-b)
			\$ 175.00	\$ -	\$ 175.00
3	<input checked="" type="checkbox"/> Goods <input type="checkbox"/> Services	K12 Saw Prop	(a)	(b)	(a-b)
			\$ 875.00	\$ -	\$ 875.00
4	<input checked="" type="checkbox"/> Goods <input type="checkbox"/> Services	Fortress Window Bar Prop (\$2,000.00) Wall Breach Prop (\$2,500.00)	(a)	(b)	(a-b)
			\$ 4,500.00	\$ -	\$ 4,500.00
5	<input type="checkbox"/> Goods <input checked="" type="checkbox"/> Services	Freight	(a)	(b)	(a-b)
			\$ 950.00	\$ -	\$ 950.00

← Check IF a Continuation D Sheet is used to account for more than one (1) project / program. IMPORTANT, if box above is checked and no continuation sheets are attached, the application will not be further considered.

E	Enter here the lesser amount of: • Sum of all items (1 thru n) under "Grant Amount Requested" • OR \$50,000 (Grant maximum)	\$13,500.00
---	---	-------------



F. Matching/Cost Share	
1	Which statement best describes the matching funds contributions? check <input checked="" type="checkbox"/> one <input type="checkbox"/> 50% or More <input type="checkbox"/> Less than 50% <input checked="" type="checkbox"/> None

G. ATL Funding	
1	What is the amount of the Applicant's FY-2015 Aid to Localities (ATL) allocation from the Fire Programs Fund? check <input checked="" type="checkbox"/> one and complete as necessary <input type="checkbox"/> \$10,000 or \$20,000 exactly <input checked="" type="checkbox"/> Other - Enter amount here <input type="text" value="\$154,986.00"/>
2	Did the Applicant have cash carry forward from FY-2015 into FY-2016 from previous years' Aid to Localities (ATL) allocations? check <input checked="" type="checkbox"/> one and complete as necessary <input checked="" type="checkbox"/> Yes <input type="checkbox"/> No If "Yes", amount of FY-2015 ATL carry forward: <input type="text" value="\$147,557.67"/>

Remarks	Make entries or check <input checked="" type="checkbox"/> <input checked="" type="checkbox"/> None	Important If the sum (1 to n) of Individual "Grant Amount Requested" in E above exceeded \$50,000, an explanation must be entered here as to how the shortfall would otherwise be made up.

EFT (EDI)
Grant awards are paid as an Electronic Funds Transfer / EDI to the current <i>account-of-record</i> for the jurisdiction's annual allocation of Aid to Localities (ATL) from the Fire Programs Fund.

Certification:				
To be completed by either: <ul style="list-style-type: none"> County Administrator –or- Executive, City Manager, Town Mayor –or- Administrator; Deputy, or... Other duly authorized official whereby the application is accompanied by a copy of an 'Ordinance' or other such formal instrument clearly granting that party such authority. 				
<p>This grant application is entered on behalf of the APPLICANT jurisdiction identified above with the knowledge and belief that all representations herein made are true and correct; with the understanding that all grant terms & conditions in-force as of the date of such application are hereby included by reference; with the further understanding that if an award is granted pursuant to this application that the recipient is bound by those same terms & conditions.</p>				
<table border="1" style="width: 100%;"> <tr> <td style="width: 50%;"><u>Kurt D. Hodgen</u> Signature</td> <td style="width: 50%;"><u>2/29/16</u> Date</td> </tr> <tr> <td><u>Kurt Hodgen</u> Printed Name</td> <td><u>City Manager</u> Title</td> </tr> </table>	<u>Kurt D. Hodgen</u> Signature	<u>2/29/16</u> Date	<u>Kurt Hodgen</u> Printed Name	<u>City Manager</u> Title
<u>Kurt D. Hodgen</u> Signature	<u>2/29/16</u> Date			
<u>Kurt Hodgen</u> Printed Name	<u>City Manager</u> Title			

(All applications must be notarized to be considered – incomplete forms shall be returned.)

State of Virginia }
 City/County of Harrisonburg }

On this 1 day of March (month) in 2016 (year), before me, the undersigned a Notary Public for the Commonwealth of Virginia, personally appeared Kurt D. Hodgen to me known (or to me proved) to be the identical person named herein and having in my presence executed the above, and acknowledged that he executed same as his voluntary act and deed.

My Commission expires: 3/1/2017 Date Erica S. Kann Notary Public



MAR 04 2016

Department of Fire Programs

Continuation Sheet D - Side 1

D		Enter a descriptive 'Title' and brief <u>Description</u> for the lead training project ^{and/or} program proposed for funding from any Grant which may be awarded pursuant to this application.	
(Title)	(Description)		
2	Forcible Entry Project		
Which statement best describes the above proposed project and/or program? check <input checked="" type="checkbox"/> one		<input type="checkbox"/> New	<input checked="" type="checkbox"/> Change to existing
Which statement best describes how many <u>training programs</u> may benefit from the proposal? check <input checked="" type="checkbox"/> one		<input checked="" type="checkbox"/> Multiple Programs	<input type="checkbox"/> Single Program
Describe the impact on training if this Grant is not awarded, or check <input checked="" type="checkbox"/>		<input type="checkbox"/> No Significant Impact	
Harrisonburg Fire Department. Without the requested props, we would not be able to provide realistic forcible entry training that is so critical to the performance of our jobs in both the residential and commercial settings.			

D		Enter a descriptive 'Title' and brief <u>Description</u> for the lead training project ^{and/or} program proposed for funding from any Grant which may be awarded pursuant to this application.	
(Title)	(Description)		
3			
Which statement best describes the above proposed project and/or program? check <input checked="" type="checkbox"/> one		<input type="checkbox"/> New	<input type="checkbox"/> Change to existing
Which statement best describes how many <u>training programs</u> may benefit from the proposal? check <input checked="" type="checkbox"/> one		<input type="checkbox"/> Multiple Programs	<input type="checkbox"/> Single Program
Describe the impact on training if this Grant is not awarded, or check <input checked="" type="checkbox"/>		<input type="checkbox"/> No Significant Impact	

D		Enter a descriptive 'Title' and brief <u>Description</u> for the lead training project ^{and/or} program proposed for funding from any Grant which may be awarded pursuant to this application.	
(Title)	(Description)		
4			
Which statement best describes the above proposed project and/or program? check <input checked="" type="checkbox"/> one		<input type="checkbox"/> New	<input type="checkbox"/> Change to existing
Which statement best describes how many <u>training programs</u> may benefit from the proposal? check <input checked="" type="checkbox"/> one		<input type="checkbox"/> Multiple Programs	<input type="checkbox"/> Single Program
Describe the impact on training if this Grant is not awarded, or check <input checked="" type="checkbox"/>		<input type="checkbox"/> No Significant Impact	

Be sure that if this continuation work sheet is used, your application is both properly marked and this sheet is included with your application filing.

Department of Fire Programs

MAR 04 2015

Administration

Continuation Sheet E - Side 1

MAR 04 2023

E In the below table itemize in priority order – starting with the most needed first, **ALL** items of "Goods" (e.g. equipment, hardware or other durable items) or categories of "Services" which are to be funded in whole or in part from any Grant which may be awarded pursuant to this application.

Enter Project Number from [D] above	Check <input checked="" type="checkbox"/> One	Description	Total Cost	Less any Matching Funds	Grant Amount Requested
6	<input type="checkbox"/> Goods		(a)	(b)	(a-b)
	<input type="checkbox"/> Services		\$ -	\$ -	\$ -
7	<input type="checkbox"/> Goods		(a)	(b)	(a-b)
	<input type="checkbox"/> Services		\$ -	\$ -	\$ -
8	<input type="checkbox"/> Goods		(a)	(b)	(a-b)
	<input type="checkbox"/> Services		\$ -	\$ -	\$ -
9	<input type="checkbox"/> Goods		(a)	(b)	(a-b)
	<input type="checkbox"/> Services		\$ -	\$ -	\$ -
10	<input type="checkbox"/> Goods		(a)	(b)	(a-b)
	<input type="checkbox"/> Services		\$ -	\$ -	\$ -
11	<input type="checkbox"/> Goods		(a)	(b)	(a-b)
	<input type="checkbox"/> Services		\$ -	\$ -	\$ -
12	<input type="checkbox"/> Goods		(a)	(b)	(a-b)
	<input type="checkbox"/> Services		\$ -	\$ -	\$ -

Be sure that the total of ALL "Grant Amount Requested" entries are properly accounted for in the final line of Section E of your application. Also, be sure that if this continuation work sheet is used, your application is both properly marked and this sheet is included with your filing of the application.

Continuation Sheet E - Side 2

13	<input type="checkbox"/> Goods		(a)	(b)	(a-b)
	<input type="checkbox"/> Services		\$ -	\$ -	\$ -



City of Harrisonburg, Virginia

FIRE DEPARTMENT

101 North Main Street
Harrisonburg, VA 22802
(540) 432-7703 FAX (540) 432-7780

Larry W. Shifflett
Fire Chief

Memorandum of Understanding Between

The Harrisonburg Fire Department, Rockingham County Department of Fire and Rescue, and
Massanutten Technical Center

SUBJECT: Multi-Jurisdictional Regional Training Partnership

Purpose: The Harrisonburg Fire Department Regional Training Center, located at 320 East Mosby Road, Harrisonburg, Virginia is owned and maintained by the City of Harrisonburg. It is a facility funded by grant money received from the Virginia Department of Fire Programs, the Virginia Fire Services Board Burn Building Grant Program, as well as additional funding from the locality. The center is open for all local and regional partners for their training needs. This MOU outlines the partnership for use of the buildings and associated training props between Harrisonburg Fire Department, the career and volunteer members of the Rockingham County Department of Fire and Rescue, and the instructors and students of the Fire/Rescue Program of the Massanutten Technical Center, and is inclusive of other regional partners.

Scope: This MOU provides the understanding the Harrisonburg Fire Department, will continue to maintain the training center mentioned above and all associated training props, and the neighboring County of Rockingham and Massanutten Technical Center, and other regional partners have the ability to use these props as needed unless otherwise in use. If the Training Center is used by any of the regional partners, the respective partner would be responsible for the replacement of the materials used to conduct the training. There would be no other cost associated. While those agencies mentioned in this MOU are the regional partners that would be the primary users of the facility, the Training Center would be available to other localities as well. It is the responsibility of the user to ensure that all training and/or other activities are conducted in accordance with NFPA and OSHA guidelines.

Contracting Period: The period in which this MOU will be in effect shall be based upon the fiscal year, beginning on July 1st of current year and ending on June 30th of the following year. This MOU shall be evaluated and renewed prior to the end of each fiscal year.

Monetary Terms: This MOU further outlines that each user of the Training Center shall document the materials utilized for training and replace said materials within 30 days of use. The agency utilizing the training facility shall be responsible for any and all costs associated with any incident or accident which may occur during the training evolutions, as well as provide their own insurance.



Quote No. 0059
Date: FEB. 24, 2016

201 Gregson Court
Box 274, Fergus, ON
N1M 2W8
(519) 843-4011, Fax (519) 843-3314
hrmachine@bellnet.ca

HARRISONBURG FIRE DEPT.

ATTN: DC MIKE BRADY

Description: SUPPLY

1 - 2 nd GENERATION FORCIBLE ENTRY DOOR SIMULATOR.....	\$7000.00
1 – HIGH SECURITY PADLOCK SIMULATOR.....	\$175.00
1 – K12 SAW PROP.....	\$875.00
1 – FORTRESS WINDOW BAR PROP.....	\$2000.00
1 – WALL BREACH PROP.....	\$2500.00
FREIGHT.....	<u>\$950.00</u>
TOTAL.....	<u>\$13500.00</u>

Pricing is based on complete order

The quoted price includes shipping of 1 fully assembled, ready to use 2nd Generation Forcible Entry Door Simulator to your location. No taxes applicable on product or shipping under NAFTA

Trusting the above is in order, we remain

Yours very truly,
Jamie F. Hiller
Jamie F. Hiller

****Quote in effect for 14 days from above captioned date. Applicable taxes not included****



City of Harrisonburg, Virginia

FIRE DEPARTMENT

101 North Main Street
Harrisonburg, VA 22802
(540) 432-7703 FAX (540) 432-7780

Larry W. Shifflett
Fire Chief

March 1, 2016

VDFP Grants and Local Aid Manager
1005 Technology Park Drive
Glen Allen, VA 23059-4500

To Whom It May Concern,

Attached to this letter you will find the FY 2016 Regional Fire Services Training Facilities Grant Application for the Harrisonburg Fire Department Regional Training Facility. The grant is for forcible entry props to be used at the training center. The grant total is \$13,500.00. Thank you for your time and consideration with this matter.

Michael Brady, Deputy Fire Chief
Harrisonburg Fire Department

Department of Fire Programs

MAR 04 2016

Administration



General Instructions & Notices

- Applicants are directed to "**Regional Fire Services Training Facilities Grant Program Policy**" as amended for the current funding year which is incorporated by reference to all applications and any subsequent awards. (Such practices document is inclusive of all *terms & conditions*.)
- The filing of an application does not bind the Board to award nor the Department to pay any such grant.
- Incomplete applications and those received after the deadline will not be considered.
(Deadline) → **March 1, 2016** postmarked
- Completed applications executed by the competent authority will only be accepted directly from jurisdictions not fire departments.
- Timeliness of filing and subsequent receipt by the Agency are solely the applicant's responsibility – all applications must be completed in ink and sent directly to: **VDFP Grants and Local Aid Manager,**
Address → 1005 Technology Park Drive, Glen Allen VA 23059-4500
- All decisions regarding grant awards made by the Board are final; applicants may appeal decisions in writing to the address provided above within 15 business days of the posting of awards.

A. Applicant Information

1. Title of Lead Jurisdiction Making Application (Check <input checked="" type="checkbox"/> only one, then make entry)			County of	
	<input checked="" type="checkbox"/>		City of	<u>Lynchburg</u>
			Incorporated Town of	
2. Employer Identification Number (EIN)	[REDACTED]			
3. Principal Point of Contact	(Include salutation, name & title.) Mr. Jonathan R. Wright, Battalion Chief - Training Division			
4. Mailing Address (Include zip code) Identify COUNTY if appropriate	800 Madison Street Lynchburg, Virginia 24504			
5. Telephone Number	(434)	455-6353		
6. FAX Number	(434)	847-1742		
7. Internet e-mail address	<u>jonathan.wright@lynchburgva.gov</u>			

B. Additional Parties

	Identify ALL jurisdictions (Not Fire Departments) participating in the proposed project. Attach additional sheets as may be required.
1. Formal Agreement Among Parties	<p>In accordance with Program Policy, multi-jurisdictional regional training partnerships must be documented (e.g. MOA, MOU, etc.) as required supporting documentation to the Application for consideration of Program funding.</p> <p>A copy of the Agreement has been attached to this application. <input checked="" type="checkbox"/> Yes <input type="checkbox"/> No</p> <p><i>If a copy of the Agreement has not been attached as required supporting documentation, this Application will be considered incomplete and funding will not be approved.</i></p>

Department of Fire Programs

MAR 03 2016

Administration



(Reproduce and complete as many additional blocs as may be necessary for complete disclosure.)

2a. Complete <u>one each</u> for ALL other Parties of Interest	Number <input type="text" value="2"/> of a total of <input type="text" value="3"/> parties to proposed project <small>(Count the LEAD Locality as #1, thereby start with #2.)</small>
2b. Title of Jurisdiction <small>(Check <input checked="" type="checkbox"/> only one, then make entry)</small>	<input checked="" type="checkbox"/> County of <u>Amherst</u> <input type="checkbox"/> City of _____ <input type="checkbox"/> Incorporated Town of _____
2c. Employer Identification Number (EIN)	[REDACTED]
2d. Principal Point of Contact <small>(Include salutation, name & title.)</small>	Mr. Gary Roakes - Director of Public Safety
2e. Mailing Address <small>(Include zip code+4)</small> <small>Identify COUNTY if appropriate -</small>	P.O. Box 140 119 Taylor Street Amhest, VA 24521
2f. Telephone Number	(434) 946-9307
2g. FAX Number	(434) 946-9470
2h. Internet e-mail address	gmroakes@countyofamherst.com

Administration
MAR 03 2016

Department of Fire Programs

(Reproduce and complete as many additional blocs as may be necessary for complete disclosure.)

2a. Complete <u>one each</u> for ALL other Parties of Interest	Number <input type="text" value="3"/> of a total of <input type="text" value="3"/> parties to proposed project <small>(Count the LEAD Locality as #1, thereby start with #2.)</small>
2b. Title of Jurisdiction <small>(Check <input checked="" type="checkbox"/> only one, then make entry)</small>	<input checked="" type="checkbox"/> County of <u>Campbell</u> <input type="checkbox"/> City of _____ <input type="checkbox"/> Incorporated Town of _____
2c. Employer Identification Number (EIN)	[REDACTED]
2d. Principal Point of Contact <small>(Include salutation, name & title.)</small>	Mrs. Tracy M. Fairchild, Director
2e. Mailing Address <small>(Include zip code+4)</small> <small>Identify COUNTY if appropriate -</small>	PO Box 500 Rustburg VA 24588
2f. Telephone Number	(##) 332-9540
2g. FAX Number	(434) 332-2957
2h. Internet e-mail address	tmfairchild@campbellcountyva.gov

(Reproduce and complete as many additional blocs as may be necessary for complete disclosure.)

2a. Complete <u>one each</u> for ALL other Parties of Interest	Number <input type="text"/> of a total of <input type="text"/> parties to proposed project <small>(Count the LEAD Locality as #1, thereby start with #2.)</small>
2b. Title of Jurisdiction <small>(Check <input checked="" type="checkbox"/> only one, then make entry)</small>	<input type="checkbox"/> County of _____ <input type="checkbox"/> City of _____ <input type="checkbox"/> Incorporated Town of _____
2c. Employer Identification Number (EIN)	[REDACTED]
2d. Principal Point of Contact <small>(Include salutation, name & title.)</small>	
2e. Mailing Address <small>(Include zip code+4)</small> <small>Identify COUNTY if appropriate -</small>	
2f. Telephone Number	()
2g. FAX Number	()
2h. Internet e-mail address	



C. Previous Applications/Awards

1.	Has the Applicant previously applied for a RFSTF Grant from the Board? - check <input checked="" type="checkbox"/> one	<input checked="" type="checkbox"/> No	<input type="checkbox"/> Yes
2.	Has the Applicant previously received a RFSTF Grant from the Board? - check <input checked="" type="checkbox"/> one	<input checked="" type="checkbox"/> No	<input type="checkbox"/> Yes

D. Project Title(s) and Description(s) Enter a descriptive 'Title' and brief 'Description' for the lead training project and/or program proposed for funding from any Grant which may be awarded pursuant to this application.

(Project Title)	(Description)
1 Swede Phase 1 - Flashover Class A Prop	The Drager Rescue Systems Phase 1 Class A flashover simulator provides comprehensive fire behavior training for recruit and experienced firefighters serving the Central Virginia area. This model simulator system meets or exceeds relevant NFPA standards 1403 and 1500.
Which statement best describes the above proposed project and/or program? check <input checked="" type="checkbox"/> one	<input checked="" type="checkbox"/> New <input type="checkbox"/> Change to existing <input type="checkbox"/> Continuing
Which statement best describes how many training programs may benefit from the proposal? check <input checked="" type="checkbox"/> one	<input checked="" type="checkbox"/> Multiple Programs <input type="checkbox"/> Single Program
Describe the impact on training if this Grant is not awarded, or check <input checked="" type="checkbox"/> No Significant Impact	
At present, members of the Lynchburg Fire Department and surrounding county fire departments in Amherst, Bedford, and Campbell do not have the ability to demonstrate the concepts delivered during the fire behavior section of Firefighter I and II programs as it relates to flashovers. As we continue to provide fire dynamics training to all members, a flashover simulator is a critical need moving forward.	
<input type="checkbox"/> ← Check <input checked="" type="checkbox"/> IF a Continuation D Sheet is used to account for more than one (1) project / program . IMPORTANT , if box above is checked and no continuation sheets are attached, the application will not be further considered.	

E. Project Goods & Services Requested In the below table, itemize in priority order – starting with the most needed first, ALL items of "Goods" (e.g. equipment, hardware or other durable items) or categories of "Services" which are to be funded in whole or in part from any Grant which may be awarded pursuant to this application.

Enter Project Title from [D] above	Check <input checked="" type="checkbox"/> One	Description	Total Cost	Less any Matching Funds	Grant Amount Requested
1	<input checked="" type="checkbox"/> Goods	Class A Flashover Simulator. Includes Simulator Unit, 2-day training for "Train-the-Trainer" program for not to exceed 10 members, and shipping FOB-Destination (Lynchburg).	(a)	(b)	(a-b)
	<input type="checkbox"/> Services		\$ 38,500.00	\$ -	\$ 38,500.00
2	<input type="checkbox"/> Goods		(a)	(b)	(a-b)
	<input type="checkbox"/> Services		\$ -	\$ -	\$ -
3	<input type="checkbox"/> Goods		(a)	(b)	(a-b)
	<input type="checkbox"/> Services		\$ -	\$ -	\$ -
4	<input type="checkbox"/> Goods		(a)	(b)	(a-b)
	<input type="checkbox"/> Services		\$ -	\$ -	\$ -
5	<input type="checkbox"/> Goods		(a)	(b)	(a-b)
	<input type="checkbox"/> Services		\$ -	\$ -	\$ -

← Check IF a Continuation D Sheet is used to account for **more than one (1) project / program**.
IMPORTANT, if box above is checked and no continuation sheets are attached, the application will not be further considered.

E	Enter here the lesser amount of: • Sum of <u>all</u> items (1 thru n) under "Grant Amount Requested" • OR \$50,000 (Grant maximum)	\$ 38,500.00
---	---	---------------------

Department of Fire Programs
 Administration
 MAR 03 2016



F. Matching/Cost Share

1	Which statement best describes the matching funds contributions? <i>check <input checked="" type="checkbox"/> one</i>	<input type="checkbox"/> 50% or More	<input type="checkbox"/> Less than 50%	<input checked="" type="checkbox"/> None
---	--	--------------------------------------	--	--

G. ATL Funding

1	What is the amount of the Applicant's FY-2015 Aid to Localities (ATL) allocation from the Fire Programs Fund? <i>check <input checked="" type="checkbox"/> one and complete as necessary</i>	<input type="checkbox"/> \$10,000 or \$20,000 exactly	<input checked="" type="checkbox"/> Other - Enter amount here	\$ 239,410.00
2	Did the Applicant have cash carry forward from FY-2015 into FY-2016 from previous years' Aid to Localities (ATL) allocations? <i>check <input checked="" type="checkbox"/> one and complete as necessary</i>	<input checked="" type="checkbox"/> Yes	<input type="checkbox"/> No	If "Yes", amount of FY-2015 ATL carry forward: \$ 256,984.08

Remarks	Make entries or check <input checked="" type="checkbox"/> None	Important If the sum (1 to n) of individual "Grant Amount Requested" in E above exceeded \$50,000, an explanation must be entered here as to how the shortfall would otherwise be made up.
	Please find attached documentation in support of our grant application, which does not exceed \$50,000.	

EFT (EDI)

Grant awards are paid as an Electronic Funds Transfer / EDI to the current account-of-record for the jurisdiction's annual allocation of Aid to Localities (ATL) from the Fire Programs Fund.

Certification:

To be completed by either:

- County Administrator –or- Executive, City Manager, Town Mayor –or- Administrator; Deputy, or...
- Other duly authorized official whereby the application is accompanied by a copy of an 'Ordinance' or other such formal instrument clearly granting that party such authority.

This grant application is entered on behalf of the APPLICANT jurisdiction identified above with the knowledge and belief that all representations herein made are true and correct; with the understanding that all grant terms & conditions in-force as of the date of such application are hereby included by reference; with the further understanding that if an award is granted pursuant to this application that the recipient is bound by those same terms & conditions.

<i>Bonnie Svrcek</i> Signature	<u>3/1/2016</u> Date
BONNIE SVRCEK Printed Name	DEPUTY CITY MANAGER Title

(All applications must be notarized to be considered – Incomplete forms shall be returned.)

State of Virginia }

City County of Lynchburg }

On this 1 day of March (month) in 2016 (year), before me, the undersigned a Notary Public for the Commonwealth of Virginia, personally appeared Bonnie Svrcek to me known (or to me proved) to be the identical person named herein and having in my presence executed the above, and acknowledged that he executed same as his voluntary act and deed.

My Commission expires:

4-30-20 Date Netta V. Campbell 205167 Notary Public

{Seal}



Department of Fire Programs

MAR 03 2016

The Lynchburg Fire Department (LFD) is requesting grant funds to support a Flashover Simulator. Upon favorable review, LFD is prepared to secure simulator without delay. The Flashover simulator will be placed at the Central Virginia Regional Emergency Services Training Center (Training Center). This Flashover Simulator will serve as a training prop for VDFP Firefighter I and II courses, as well as our Modern Fire Dynamics and Basic Fire Behavior course.

LFD, established in April of 1883, is an internationally accredited fire department. LFD provides fire suppression and prevention services, emergency medical services, urban search and rescue, and hazardous materials response for approximately 76,000 Lynchburg residents, as well as the thousands who enter the area daily to work and shop. The department is staffed with 186 personnel, including civilians, firefighters and emergency medical personnel operating with eight stations covering 50-square miles. The LFD has a Training Division that is responsible for administering training to new recruits and incumbent members. The Training Division is staffed by a battalion chief, two captains, and an administrative assistant.

LFD utilizes the Training Center, situated on approximately 40 acres of property near Lynchburg Regional Airport. The LFD along with regional partners in public safety Amherst, Bedford, and Campbell Counties, and the Central Virginia Firefighters Association (CVFFA) have long standing relationships dedicated to training firefighters in the region. Partnerships formalized in the early 1980's, led to the development of the Training Center.

The Training Center has evolved through the years with many simulators and props, including:

- Class A live-fire training building
- 5-story training tower
- Indoor classroom and an outdoor pavilion
- Roof ventilation prop
- Mayday firefighter simulator
- Trench-rescue simulator
- Confined space simulator
- Forcible entry simulator
- General firefighter skills props (i.e. sprinkler and standpipe systems,

Current fiscal year projects at the Training Center include constructing new and upgraded roof simulators, the addition of an SCBA confidence course, and updates to the training classroom. These improvements will continue to enhance the training and programs offered to area firefighters into the future.

The Training Center is utilized for training new recruits and tenured members of fire departments in the region. The LFD utilizes the Training Center as the primary area for training new recruit academies. This challenging 16 weeks academy features classroom and practical evolutions including, but not limited to the following courses:

- VDFP Firefighter I and II
- Hazardous Materials Operations
- Basic Fire Behavior and Modern Fire Dynamics
- Emergency Vehicle Operators Course
- Mayday Firefighter Down!
- Emergency Medical Services Review
- Defensive Tactics
- American Heart Association CPR for Healthcare Providers
- National Fire Academy ICS 100 and 200

Tenured employees of LFD and members of the CVFFA frequent the Training Center for a wide-spectrum of skills and drills training. Brushing up on the basics is an important function of the LFD Training Division's charge too. The LFD uses the Training Center for multi-company drills, urban search and rescue, and hazardous materials team training as well. With an emphasis on the quality of education and training, and a strict adherence to safety, the Training Center has a strong record of performance through the years. All training is conducted with an eye on compliance to relevant standards, such as National Fire Protection Association's 1001 and 1403 standards.

A critical need for the Training Center is a Flashover Simulator. It is clear that this training area is an important focus for LFD and CVFFA. Flashovers occur with the sudden involvement of a room or an area in flames from floor to ceiling caused by thermal radiation feedback – essentially igniting everything simultaneously. Thus it is easy to understand that these events place firefighters in grave danger. This is why procuring a Flashover Simulator is a critical need for Central Virginia's firefighters.

The Flashover Simulator training will be delivered to recruit members to the most tenured firefighters. This training is designed to reinforce lessons to members on the vital importance of wearing proper personal protective equipment. In addition, the simulator allows instructors to describe and illustrate the stages of fire behavior so students understand when to stay in an interior fire attack mode or leave a dangerous situation. Actually witnessing the critical stages of fire behavior (in a training environment) will help students develop more effective strategies and tactics under real conditions.

The LFD and many area partners have taken advantage of Modern Fire Dynamics classroom training.

Located in the heart of Central Virginia, the Training Center is easily assessable to the fire departments in Amherst, Bedford, and Campbell Counties, as well as the City of Lynchburg and Town of Bedford. There is no alternative solution for having this important training simulator. With the help of the Regional Fire Services Training Facilities Grant, firefighters in Central Virginia will be safer and better prepared in the near future.

Dräger Safety Inc.
 Engineered Solutions
 101 Technology Drive
 Pittsburgh, PA 15275-1075

Firm Proposal
 Page: 1 of 2

Firm Proposal- PHASE 1 FLASHOVER SYSTEM

Offered Without Engagement To:

CUSTOMER:	Lynchburg Fire Department	DATE:	2-19-2016
ADDRESS:	613 Training Center Road	QUOTE #:	
CITY, STATE:	Lynchburg, VA		
ZIP:	24502		
ATTENTION:	Ronnie Coleman, Training	PHONE:	434-455-6362
TITLE:		CELL:	
E-MAIL ADDRESS:	ronald.coleman@lynchburgva.gov		
REFERENCE:	Swede Phase 1 – Flashover Class A Prop	BDM:	
DELIVERY INFO:	Standard delivery is 60 days	RSM:	Dominic Colletti

Prices are firm for 60 Days

Item	Qty	Draeger Part #	Description	Unit Price	Extension
A	1	N/A	*Drager Swede Survival Phase 1 -INCLUDES- (1) Burn room w/ corresponding crib (to build seat of fire) *Per PDF drawings provided – final engineering and design to be approved by customer before production	\$35,000.00	\$35,000.00
B	1	N/A	"Train-the-Trainer" Instructional Program ➤ The training curriculum consist's of two parts: The first part is a two day, onsite training course for up to ten (10) of the department's instructors. The second part is a complete documentation package on operation and maintenance of the System.	INCLUDED	INCLUDED
C	1	N/A	State Sales Tax		NOT INCLUDED
D		FREIGHT	Shipping to site ➤ Total system to require (1) truckload to deliver ➤ Total Weight of 21,000lbs		\$3,500
E		SET-UP	Phase 1 Product Set-up on site ➤ See Phase 1 Technical Specification for details on set-up and site requirements ➤ Set-up can be provided at an additional cost		NOT INCLUDED

Dräger Safety Inc.
Engineered Solutions
101 Technology Drive
Pittsburgh, PA 15275-1075

Firm Proposal
Page: 2 of 2

CLICK FOR MORE INFORMATION ON ALL THE SWEDE SURVIVAL PRODUCTS

http://www.draeger.com/sites/enus_us/Pages/Fire-Services/Swede-Survival.aspx?navID=369



TERMS & CONDITIONS:

1. Site preparation, i.e Concrete pad, and additional space to stage responsibility of customer
2. Off-load, staging, and final set-up to be the responsibility of customer
3. Equipment needed for set-up furnished by customer
4. Any building permits and/or trade licenses by customer and are not included
5. Taxes not included (unless requested by customer)
6. Freight only valid for 30 days
7. Training is a mandatory part of the scope of delivery and has to take place within 30 days of the set-up of the system
8. Draeger holds the right to adjust the sales price of Line Item A, if training is to take place outside the NAFTA area
9. System is not to be used with untrained operators/instructors

Total Project Costs: \$38,500.00

Notes

-- MFR std (1) year warranty applicable

Authorized Signature: *Dominic Colletti*

Name: Dominic Colletti
Title: Regional Manager, East
Mobile: 215-872-5626
Email: Dominic.Colletti@draeger.com

Confidential and Proprietary
No release without written authorization from Dräger



Fire Department

800 Madison Street • Lynchburg • Virginia • 24504

www.lynchburgva.gov • P 434-455-6340

February 19, 2016

VDFP Grants and Local Aid Manager
1005 Technology Park Drive
Glen Allen, Virginia 23059-4500

Dear Grant Coordinator:

I am pleased to present Lynchburg Fire Department's FY2016 Regional Fire Services Training Facilities Grant application for a Flashover Simulator. If successful in this grant opportunity, Lynchburg area firefighters – including our public safety partners in Amherst, Bedford, and Campbell Counties – will benefit greatly. Flashover events in today's modern building construction are a significantly greater threat to our responders, and we are hoping to combat that threat through training and education with this simulator.

Please take time to review the enclosed grant application and let me know what questions I might answer.

Warm regards,

Jonathan R. Wright,
Battalion Chief – Training Division

Department of Fire Programs

MAR 03 2016

Administration





General Instructions & Notices

- Applicants are directed to "**Regional Fire Services Training Facilities Grant Program Policy**" as amended for the current funding year which is incorporated by reference to all applications and any subsequent awards. (Such practices document is inclusive of all *terms & conditions*.)
- The filing of an application does not bind the Board to award nor the Department to pay any such grant.
- Incomplete applications and those received after the deadline will not be considered.
(Deadline) → **March 1, 2016** postmarked
- Completed applications executed by the competent authority will only be accepted directly from jurisdictions not fire departments.
- Timeliness of filing and subsequent receipt by the Agency are solely the applicant's responsibility – all applications must be completed in ink and sent directly to: **VDFP Grants and Local Aid Manager,**
Address → 1005 Technology Park Drive, Glen Allen VA 23059-4500
- All decisions regarding grant awards made by the Board are final; applicants may appeal decisions in writing to the address provided above within 15 business days of the posting of awards.

A. Applicant Information

1. Title of Lead Jurisdiction Making Application (Check <input checked="" type="checkbox"/> only one, then make entry)	<input type="checkbox"/> County of	<input type="checkbox"/> City of Martinsville	<input type="checkbox"/> Incorporated Town of
2. Employer Identification Number (EIN)	[REDACTED]		
3. Principal Point of Contact (Include salutation, name & title.)	Dan Howell, Assistant Chief		
4. Mailing Address (Include zip code) Identify COUNTY if appropriate	65 W. Church St, Martinsville, VA 24112		
5. Telephone Number	(276)	403-5325	
6. FAX Number	(276)	403-5360	
7. Internet e-mail address	dhowell@ci.martinsville.va.us		

B. Additional Parties

	Identify ALL jurisdictions (Not Fire Departments) participating in the proposed project. Attach additional sheets as may be required.
1. Formal Agreement Among Parties	<p>In accordance with Program Policy, multi-jurisdictional regional training partnerships must be documented (e.g. MOA, MOU, etc.) as required supporting documentation to the Application for consideration of Program funding.</p> <p>A copy of the Agreement has been attached to this application. <input checked="" type="checkbox"/> Yes <input type="checkbox"/> No</p> <p><i>If a copy of the Agreement has not been attached as required supporting documentation, this Application will be considered incomplete and funding will not be approved.</i></p>

Department of Fire Programs

FEB 26 2016

Administration



{ Reproduce and complete as many additional blocs as may be necessary for complete disclosure. }

2a. Complete <u>one each</u> for ALL other Parties of Interest	Number 2 of a total of 2 parties to proposed project <small>(Count the LEAD Locality as #1, thereby start with #2.)</small>									
2b. Title of Jurisdiction <small>(Check <input checked="" type="checkbox"/> only one, then make entry)</small>	<table border="1"> <tr> <td><input checked="" type="checkbox"/></td> <td>County of</td> <td>Henry</td> </tr> <tr> <td><input type="checkbox"/></td> <td>City of</td> <td></td> </tr> <tr> <td><input type="checkbox"/></td> <td>Incorporated Town of</td> <td></td> </tr> </table>	<input checked="" type="checkbox"/>	County of	Henry	<input type="checkbox"/>	City of		<input type="checkbox"/>	Incorporated Town of	
<input checked="" type="checkbox"/>	County of	Henry								
<input type="checkbox"/>	City of									
<input type="checkbox"/>	Incorporated Town of									
2c. Employer Identification Number (EIN)	[REDACTED]									
2d. Principal Point of Contact <small>(Include salutation, name & title.)</small>	Kaih Cooper, Training Coordinator									
2e. Mailing Address <small>(Include zip code+4)</small> <small>Identify COUNTY if appropriate -</small>	1024 DuPont Road, Martinsville, VA 24112									
2f. Telephone Number	() 276-634-4660									
2g. FAX Number	() 276-634 4770									
2h. Internet e-mail address	kcooper@henrycounty.va.gov									

Administration

SEP 16 2015

{ Reproduce and complete as many additional blocs as may be necessary for complete disclosure. }

2a. Complete <u>one each</u> for ALL other Parties of Interest	Number <input type="text"/> of a total of <input type="text"/> parties to proposed project <small>(Count the LEAD Locality as #1, thereby start with #2.)</small>									
2b. Title of Jurisdiction <small>(Check <input type="checkbox"/> only one, then make entry)</small>	<table border="1"> <tr> <td><input type="checkbox"/></td> <td>County of</td> <td></td> </tr> <tr> <td><input type="checkbox"/></td> <td>City of</td> <td></td> </tr> <tr> <td><input type="checkbox"/></td> <td>Incorporated Town of</td> <td></td> </tr> </table>	<input type="checkbox"/>	County of		<input type="checkbox"/>	City of		<input type="checkbox"/>	Incorporated Town of	
<input type="checkbox"/>	County of									
<input type="checkbox"/>	City of									
<input type="checkbox"/>	Incorporated Town of									
2c. Employer Identification Number (EIN)	[REDACTED]									
2d. Principal Point of Contact <small>(Include salutation, name & title.)</small>										
2e. Mailing Address <small>(Include zip code+4)</small> <small>Identify COUNTY if appropriate -</small>										
2f. Telephone Number	()									
2g. FAX Number	()									
2h. Internet e-mail address										

{ Reproduce and complete as many additional blocs as may be necessary for complete disclosure. }

2a. Complete <u>one each</u> for ALL other Parties of Interest	Number <input type="text"/> of a total of <input type="text"/> parties to proposed project <small>(Count the LEAD Locality as #1, thereby start with #2.)</small>									
2b. Title of Jurisdiction <small>(Check <input type="checkbox"/> only one, then make entry)</small>	<table border="1"> <tr> <td><input type="checkbox"/></td> <td>County of</td> <td></td> </tr> <tr> <td><input type="checkbox"/></td> <td>City of</td> <td></td> </tr> <tr> <td><input type="checkbox"/></td> <td>Incorporated Town of</td> <td></td> </tr> </table>	<input type="checkbox"/>	County of		<input type="checkbox"/>	City of		<input type="checkbox"/>	Incorporated Town of	
<input type="checkbox"/>	County of									
<input type="checkbox"/>	City of									
<input type="checkbox"/>	Incorporated Town of									
2c. Employer Identification Number (EIN)	[REDACTED]									
2d. Principal Point of Contact <small>(Include salutation, name & title.)</small>										
2e. Mailing Address <small>(Include zip code+4)</small> <small>Identify COUNTY if appropriate -</small>										
2f. Telephone Number	()									
2g. FAX Number	()									
2h. Internet e-mail address										



C. Previous Applications/Awards

1.	Has the Applicant previously applied for a RFSTF Grant from the Board? - check <input checked="" type="checkbox"/> one	<input checked="" type="checkbox"/> No	<input type="checkbox"/> Yes
2.	Has the Applicant previously received a RFSTF Grant from the Board? - check <input checked="" type="checkbox"/> one	<input checked="" type="checkbox"/> No	<input type="checkbox"/> Yes

D. Project Title(s) and Description(s) Enter a descriptive 'Title' and brief 'Description' for the lead training project and/or program proposed for funding from any Grant which may be awarded pursuant to this application.

1	(Project Title) Install existing compressor at Henry County Training Center	(Description) Older compressor located at Martinsville Fire Department is being replaced and installed in a new building at the training center. This building does not have the power necessary to run the compressor. Three phase power has to be supplied to this building.
Which statement best describes the above proposed project and/or program? check <input checked="" type="checkbox"/> one		
<input type="checkbox"/> New <input checked="" type="checkbox"/> Change to existing <input type="checkbox"/> Continuing		
Which statement best describes how many training programs may benefit from the proposal? check <input checked="" type="checkbox"/> one		
<input checked="" type="checkbox"/> Multiple Programs <input type="checkbox"/> Single Program		
Describe the impact on training if this Grant is not awarded, or check <input type="checkbox"/> No Significant Impact		
Need a reliable air compressor at the training center. Every class that involves the use of SCBA is negatively impacted by the lack of a reliable air compressor.		
<input type="checkbox"/> ← Check <input checked="" type="checkbox"/> IF a Continuation D Sheet is used to account for more than one (1) project / program. IMPORTANT, if box above is checked and no continuation sheets are attached, the application will not be further considered.		

Administration

FEB 26 2016

Department of Fire Programs

E. Project Goods & Services Requested In the below table, itemize in priority order – starting with the most needed first, ALL items of "Goods" (e.g. equipment, hardware or other durable items) or categories of "Services" which are to be funded in whole or in part from any Grant which may be awarded pursuant to this application.

Enter Project Title from [D] above	Check <input checked="" type="checkbox"/> One	Description	Total Cost	Less any Matching Funds	Grant Amount Requested
1	<input type="checkbox"/> Goods <input checked="" type="checkbox"/> Services	Install existing compressor and run three phase power to the building.	(a)	(b)	(a-b)
		Three Phase Power - \$20,000	\$ 20,000.00	\$ -	\$ 20,000.00
2	<input type="checkbox"/> Goods <input type="checkbox"/> Services		(a)	(b)	(a-b)
			\$ -	\$ -	\$ -
3	<input type="checkbox"/> Goods <input type="checkbox"/> Services		(a)	(b)	(a-b)
			\$ -	\$ -	\$ -
4	<input type="checkbox"/> Goods <input type="checkbox"/> Services		(a)	(b)	(a-b)
			\$ -	\$ -	\$ -
5	<input type="checkbox"/> Goods <input type="checkbox"/> Services		(a)	(b)	(a-b)
			\$ -	\$ -	\$ -

← Check IF a Continuation D Sheet is used to account for **more than one (1) project / program.**
IMPORTANT, if box above is checked and no continuation sheets are attached, the application will not be further considered.

E	Enter here the lesser amount of: <ul style="list-style-type: none"> Sum of all items (1 thru n) under "Grant Amount Requested" OR \$50,000 (Grant maximum) 	\$ 20,000.00
---	---	--------------



F. Matching/Cost Share

1	Which statement best describes the matching funds contributions? <i>check <input checked="" type="checkbox"/> one</i>	<input type="checkbox"/> 50% or More	<input type="checkbox"/> Less than 50%	<input checked="" type="checkbox"/> None
---	--	--------------------------------------	--	--

G. ATL Funding

1	What is the amount of the Applicant's FY-2015 Aid to Localities (ATL) allocation from the Fire Programs Fund? <i>check <input checked="" type="checkbox"/> one and complete as necessary</i>	<input type="checkbox"/> \$10,000 or \$20,000 exactly	<input checked="" type="checkbox"/> Other - Enter amount here	\$ 39,000.00
2	Did the Applicant have cash carry forward from FY-2015 into FY-2016 from previous years' Aid to Localities (ATL) allocations? <i>check <input checked="" type="checkbox"/> one and complete as necessary</i>	<input checked="" type="checkbox"/> Yes	<input type="checkbox"/> No	If "Yes", amount of FY-2015 ATL carry forward: \$ 71,587.00

Remarks	Make entries or check <input checked="" type="checkbox"/> <input type="checkbox"/> None	Important - If the sum (1 to n) of individual "Grant Amount Requested" in E above exceeded \$50,000, an explanation must be entered here as to how the shortfall would otherwise be made up.
	Please refer to enclosed letter.	

EFT (EDI)

Grant awards are paid as an **Electronic Funds Transfer / EDI** to the current *account-of-record* for the jurisdiction's annual allocation of Aid to Localities (ATL) from the Fire Programs Fund.

Certification:

To be completed by either:

- County Administrator –or- Executive, City Manager, Town Mayor –or- Administrator; Deputy, or...
- Other duly authorized official whereby the application is accompanied by a copy of an 'Ordinance' or other such formal instrument clearly granting that party such authority.

This grant application is entered on behalf of the APPLICANT jurisdiction identified above with the knowledge and belief that all representations herein made are true and correct; with the understanding that all grant terms & conditions in-force as of the date of such application are hereby included by reference; with the further understanding that if an award is granted pursuant to this application that the recipient is bound by those same terms & conditions.

	2/22/16
Signature	Date
LEON TOWARNICKI	CITY MANAGER
Printed Name	Title

(All applications must be notarized to be considered – incomplete forms shall be returned.)

State of Virginia }
City / County of Morrisville }

On this 22 day of Feb. (month) in 2016 (year), before me, the undersigned a Notary Public for the Commonwealth of Virginia, personally appeared Leon Towarnicki to me known (or to me proved) to be the identical person named herein and having in my presence executed the above, and acknowledged that he executed same as his voluntary act and deed.

My Commission expires: 12-31-19 # 141333
Date Notary Public Zeddy K. Anderson {Seal}

Department of Fire Programs
 FEB 26 2016
 Administration



COUNTY OF HENRY
DEPARTMENT OF PUBLIC SAFETY

1024 DuPont Road
Martinsville, VA 24112
Voice: 276.634.4660
fax: 276.634.4770

September 15, 2010

Chief Kenneth Draper
Martinsville Fire & EMS
65 W. Church Street
Martinsville, VA 24112

Dear Chief Draper,

As Henry County embarks upon significant changes in the delivery of emergency medical services, it is reassuring to know we can continue to count on our long standing mutual aid agreement with Martinsville Fire & EMS. As we discussed, Martinsville Fire & EMS will continue to provide mutual aid response to fire and EMS calls in Henry County when requested and as available. Likewise, Henry County will continue to provide mutual aid response to fire and EMS calls in Martinsville when requested and as available.

I thank you for willingness to work together. If I may be of assistance to you, please call.

Sincerely,

A handwritten signature in cursive script that reads "Dale Wagoner".

Dale Wagoner
Public Safety Director

Cc: EMS Coordinator

Triangle Electric Corporation



560 Bouldin Road
Ridgeway, VA 24148
Woman Owned Small Business
Phone (276) 957-2281 Fax (276) 957-1049

Quotation

DATE February 12, 2016

Quotation # 976

Quotation valid until: March 13, 2016
Prepared by: Charles Bradshaw

Henry County Public Safety
Mr. Cooper

Reference: Henry County Public Safety "Burn Building"

Description	Amount
<p>This quotation is in reference to the electrical service for a new air compressor at the "Burn Building" at Henry County Public Safety. We are pleased to quote a turnkey price for the electrical. This price includes Appalachian Power installing transformers and metering equipment. Also installed will be a 200 amp / 3 phase / 240 volt electrical service.</p> <p>**Price:</p> <p>Thank you for the opportunity to supply you with a price quotation.</p>	<p>\$ 20,000.00</p>
<p>All wiring to meet the requirements of the adopted National Electrical Code in effect.</p>	

If you have any questions concerning this quotation, please contact our office.

THANK YOU FOR YOUR BUSINESS!



February 18, 2016

Grants and Local Aid Manager
Virginia Department of Fire Programs
1005 Technology Park Drive
Glen Allen, VA 23059-4500

Since 1991, the City of Martinsville and Henry County has shared an Eagle air compressor located at Martinsville Fire & EMS. This compressor was used by all fire departments in Henry County as well as Martinsville Fire & EMS. Recently, Martinsville Fire & EMS purchased a new compressor that will replace this older air compressor. The intent was to move the Eagle air compressor to the Martinsville and Henry County Fire Training Center located at 1024 Dupont Road in Henry County.

This was deemed necessary because the current air compressor at the training center is an old diesel unit left over from the DuPont era that is constantly plagued with break downs and high maintenance costs. As a result, every class that involves the use of SCBA is negatively impacted by the lack of a reliable compressor at the training center.

The Eagle compressor to be moved to the training center uses a three phase motor. Unfortunately, three phase power is not supplied to the training center. This leaves Martinsville and Henry County with four options. First, the localities could do nothing and simply let the Eagle compressor sit unused at the training center. Second, a new compressor could be purchased for the training center. Third, the Eagle compressor could be converted to single phase power. Finally, three phase power could be installed at the training center.

After evaluating the four options, it was decided that it would be preferable to make use of the Eagle compressor. Research determined that it would be possible to convert the compressor motor over to single phase but Eagle Air Compressor was unable to verify if the internal compressor controls would work on single phase. This leaves installing three phase power at the training center as the best option for the two localities.

Accordingly, this grant is requesting the funds to establish three phase power at the Martinsville and Henry County Training Center. This project would involve a new transformer and meter

base installation at the training center and appropriate upgrades to the electrical panels and wiring inside the compressor storage building. The cost for this project is estimated to be \$20,000. This is a large expense to allow the use of the Eagle compressor at the training center but is still considerably cheaper than purchasing a new compressor. The new electrical service would also eliminate the uncertainty of attempting to convert the Eagle compressor to single phase power since there is no guarantee from the manufacturer that this will work. Finally, the new electrical service would represent a major infrastructure improvement for the training center and prepare it for any future expansion of services.

In summary, Martinsville Fire & EMS is requesting the funds to install an existing compressor at the regional training center. The requested funds would cover the cost of the necessary electrical upgrades to facilitate the installation of the compressor. If you have any additional questions, please feel free to contact me.

Respectfully,

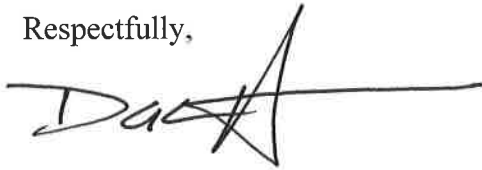
A handwritten signature in black ink, appearing to read "Dan Howell", with a long horizontal line extending to the right.

Dan Howell
Assistant Chief



General Instructions & Notices

- Applicants are directed to "**Regional Fire Services Training Facilities Grant Program Policy**" as amended for the current funding year which is incorporated by reference to all applications and any subsequent awards. (Such practices document is inclusive of all *terms & conditions*.)
- The filing of an application does not bind the Board to award nor the Department to pay any such grant.
- Incomplete applications and those received after the deadline will not be considered.
(Deadline) → **March 1, 2016** postmarked
- Completed applications executed by the competent authority will only be accepted directly from jurisdictions not fire departments.
- Timeliness of filing and subsequent receipt by the Agency are solely the applicant's responsibility – all applications must be completed in ink and sent directly to: **VDFP Grants and Local Aid Manager**,
Address → 1005 Technology Park Drive, Glen Allen VA 23059-4500
- All decisions regarding grant awards made by the Board are final; applicants may appeal decisions in writing to the address provided above within 15 business days of the posting of awards.

A. Applicant Information

1. Title of Lead Jurisdiction Making Application (Check <input checked="" type="checkbox"/> only one, then make entry)	<input type="checkbox"/> County of	<input type="checkbox"/> City of Roanoke, VA	<input type="checkbox"/> Incorporated Town of
2. Employer Identification Number (EIN)	[REDACTED]		
3. Principal Point of Contact	(Include salutation, name & title.) Tiffany Bradbury, Fire Prevention Specialist		
4. Mailing Address (Include zip code) Identify COUNTY if appropriate	713 Third St., SW Roanoke, VA 24016		
5. Telephone Number	(540)	853-5785	
6. FAX Number	(540)	853-1172	
7. Internet e-mail address	[REDACTED]		

B. Additional Parties

	Identify ALL jurisdictions (Not Fire Departments) participating in the proposed project. Attach additional sheets as may be required.
1. Formal Agreement Among Parties	<p>In accordance with Program Policy, multi-jurisdictional regional training partnerships must be documented (e.g. MOA, MOU, etc.) as required supporting documentation to the Application for consideration of Program funding.</p> <p>A copy of the Agreement has been attached to this application. <input checked="" type="checkbox"/> Yes <input type="checkbox"/> No</p> <p><i>If a copy of the Agreement has not been attached as required supporting documentation, this Application will be considered incomplete and funding will not be approved.</i></p>

Department of Fire Programs

FEB 26 2016

Administration



(Reproduce and complete as many additional blocs as may be necessary for complete disclosure.)

2a. Complete <u>one each</u> for ALL other Parties of Interest	Number <input type="text" value="1"/> of a total of <input type="text" value="3"/> parties to proposed project <small>(Count the LEAD Locality as #1, thereby start with #2.)</small>									
2b. Title of Jurisdiction <small>(Check <input checked="" type="checkbox"/> only one, then make entry)</small>	<table border="1"> <tr> <td><input type="checkbox"/></td> <td>County of</td> <td></td> </tr> <tr> <td><input checked="" type="checkbox"/></td> <td>City of</td> <td>Roanoke, VA</td> </tr> <tr> <td><input type="checkbox"/></td> <td>Incorporated Town of</td> <td></td> </tr> </table>	<input type="checkbox"/>	County of		<input checked="" type="checkbox"/>	City of	Roanoke, VA	<input type="checkbox"/>	Incorporated Town of	
<input type="checkbox"/>	County of									
<input checked="" type="checkbox"/>	City of	Roanoke, VA								
<input type="checkbox"/>	Incorporated Town of									
2c. Employer Identification Number (EIN)	<div style="background-color: black; width: 100px; height: 15px;"></div>									
2d. Principal Point of Contact <small>(Include salutation, name & title.)</small>	Tiffany Bradbury, Fire Prevention Specialist									
2e. Mailing Address <small>(Include zip code+4)</small> <small>Identify COUNTY if appropriate -</small>	713 Third St., SW Roanoke, VA 24016									
2f. Telephone Number	(540) 853-5785									
2g. FAX Number	(540) 853-1172									
2h. Internet e-mail address	tiffany.bradbury@roanokeva.gov									

Department of Fire Programs

Administration
FEB 26 2016

(Reproduce and complete as many additional blocs as may be necessary for complete disclosure.)

2a. Complete <u>one each</u> for ALL other Parties of Interest	Number <input type="text" value="1"/> of a total of <input type="text" value="3"/> parties to proposed project <small>(Count the LEAD Locality as #1, thereby start with #2.)</small>									
2b. Title of Jurisdiction <small>(Check <input checked="" type="checkbox"/> only one, then make entry)</small>	<table border="1"> <tr> <td><input checked="" type="checkbox"/></td> <td>County of</td> <td>Roanoke, VA</td> </tr> <tr> <td><input type="checkbox"/></td> <td>City of</td> <td></td> </tr> <tr> <td><input type="checkbox"/></td> <td>Incorporated Town of</td> <td></td> </tr> </table>	<input checked="" type="checkbox"/>	County of	Roanoke, VA	<input type="checkbox"/>	City of		<input type="checkbox"/>	Incorporated Town of	
<input checked="" type="checkbox"/>	County of	Roanoke, VA								
<input type="checkbox"/>	City of									
<input type="checkbox"/>	Incorporated Town of									
2c. Employer Identification Number (EIN)	<div style="background-color: black; width: 100px; height: 15px;"></div>									
2d. Principal Point of Contact <small>(Include salutation, name & title.)</small>	Chief Steve Simon									
2e. Mailing Address <small>(Include zip code+4)</small> <small>Identify COUNTY if appropriate -</small>	5925 Cove Rd. Roanoke, VA 24019									
2f. Telephone Number	()									
2g. FAX Number	()									
2h. Internet e-mail address	steve.simon@roanokeva.gov									

(Reproduce and complete as many additional blocs as may be necessary for complete disclosure.)

2a. Complete <u>one each</u> for ALL other Parties of Interest	Number <input type="text" value="3"/> of a total of <input type="text" value="3"/> parties to proposed project <small>(Count the LEAD Locality as #1, thereby start with #2.)</small>									
2b. Title of Jurisdiction <small>(Check <input checked="" type="checkbox"/> only one, then make entry)</small>	<table border="1"> <tr> <td><input type="checkbox"/></td> <td>County of</td> <td></td> </tr> <tr> <td><input checked="" type="checkbox"/></td> <td>City of</td> <td>Salem, VA</td> </tr> <tr> <td><input type="checkbox"/></td> <td>Incorporated Town of</td> <td></td> </tr> </table>	<input type="checkbox"/>	County of		<input checked="" type="checkbox"/>	City of	Salem, VA	<input type="checkbox"/>	Incorporated Town of	
<input type="checkbox"/>	County of									
<input checked="" type="checkbox"/>	City of	Salem, VA								
<input type="checkbox"/>	Incorporated Town of									
2c. Employer Identification Number (EIN)	<div style="background-color: black; width: 100px; height: 15px;"></div>									
2d. Principal Point of Contact <small>(Include salutation, name & title.)</small>	Chief John Prillaman									
2e. Mailing Address <small>(Include zip code+4)</small> <small>Identify COUNTY if appropriate -</small>	216 S. Broad St. Salem, VA 24153									
2f. Telephone Number	()									
2g. FAX Number	()									
2h. Internet e-mail address	jprillaman@salemva.gov									



C. Previous Applications/Awards

1.	Has the Applicant previously applied for a RFSTF Grant from the Board? - check <input checked="" type="checkbox"/> one	<input checked="" type="checkbox"/> No	<input type="checkbox"/> Yes
2.	Has the Applicant previously received a RFSTF Grant from the Board? - check <input checked="" type="checkbox"/> one	<input checked="" type="checkbox"/> No	<input type="checkbox"/> Yes

D. Project Title(s) and Description(s) Enter a descriptive "Title" and brief "Description" for the lead training project and/or program proposed for funding from any Grant which may be awarded pursuant to this application.

(Project Title)	(Description)
1 Mobile Training Capabilities for Roanoke Valley Regional Fire-EMS Training Center	The Roanoke Valley Regional Fire-EMS Training Center conducts training for Roanoke Fire-EMS, Roanoke County Fire & Rescue and Salem Fire-EMS. Much of this training is held away from the training center and we are in need of a trailer and tools to train at mobile destinations.
Which statement best describes the above proposed project and/or program? check <input checked="" type="checkbox"/> one	
<input checked="" type="checkbox"/> New <input type="checkbox"/> Change to existing <input type="checkbox"/> Continuing	
Which statement best describes how many training programs may benefit from the proposal? check <input checked="" type="checkbox"/> one	
<input checked="" type="checkbox"/> Multiple Programs <input type="checkbox"/> Single Program	
Describe the impact on training if this Grant is not awarded, or check <input checked="" type="checkbox"/> No Significant Impact	
If this grant is not awarded, the safety of our firefighters could be in jeopardy. Currently we don't have a way to transport equipment for off-site training in a safe manner. As of now some gear is loosely carried which causes a projectile danger to the occupants of the vehicle. This equipment would be used quite often, specifically during our regional recruit school training evolutions.	
<input type="checkbox"/> ← Check <input checked="" type="checkbox"/> IF a Continuation D Sheet is used to account for more than one (1) project / program.	
IMPORTANT , if box above is checked and no continuation sheets are attached, the application will not be further considered.	

E. Project Goods & Services Requested In the below table, itemize in priority order – starting with the most needed first, ALL items of "Goods" (e.g. equipment, hardware or other durable items) or categories of "Services" which are to be funded in whole or in part from any Grant which may be awarded pursuant to this application.

Enter Project Title from [D] above	Check <input checked="" type="checkbox"/> One	Description	Total Cost	Less any Matching Funds	Grant Amount Requested
1 Mobile Training	<input checked="" type="checkbox"/> Goods	8.5x20 Hercules Trailer, White with 7'8" int. ht. and ramp door rear with 32" side door & 24" stone guard with vnose side flow thru vents	(a)	(b)	(a-b)
	<input type="checkbox"/> Services	9950 GVWR with radial tires & LED lights	\$ 6,299.00	\$ -	\$ 6,299.00
2 Mobile Training	<input checked="" type="checkbox"/> Goods	Training equipment & mounting brackets including: power tools, gas powered fans, hand tools, rakes, shovels, salvage & overhaul equipment and rope equipment.	(a)	(b)	(a-b)
	<input type="checkbox"/> Services		\$ 8,701.00	\$ -	\$ 8,701.00
3	<input type="checkbox"/> Goods		(a)	(b)	(a-b)
	<input type="checkbox"/> Services		\$ -	\$ -	\$ -
4	<input type="checkbox"/> Goods		(a)	(b)	(a-b)
	<input type="checkbox"/> Services		\$ -	\$ -	\$ -
5	<input type="checkbox"/> Goods		(a)	(b)	(a-b)
	<input type="checkbox"/> Services		\$ -	\$ -	\$ -

← Check IF a Continuation D Sheet is used to account for more than one (1) project / program. **IMPORTANT**, if box above is checked and no continuation sheets are attached, the application will not be further considered.

E	Enter here the lesser amount of: • Sum of all items (1 thru n) under "Grant Amount Requested" • OR \$50,000 (Grant maximum)	\$ 15,000.00
---	--	---------------------

Continuation Sheet D - Side 1

Department of Fire Programs

FEB 26 2016

Administration

D	<i>Enter a descriptive 'Title' and brief Description for the lead training project and/or program proposed for funding from any Grant which may be awarded pursuant to this application.</i>	
2	(Title)	(Description)
	Which statement best describes the above proposed project and/or program? <i>check <input checked="" type="checkbox"/> one</i>	
	<input type="checkbox"/> New	<input type="checkbox"/> Change to existing <input type="checkbox"/> Continuing
	Which statement best describes how many <u>training programs</u> may benefit from the proposal? <i>check <input checked="" type="checkbox"/> one</i>	
	<input type="checkbox"/> Multiple Programs	<input type="checkbox"/> Single Program
	Describe the impact on training if this Grant is not awarded, or check <input checked="" type="checkbox"/>	
		No Significant Impact

D	<i>Enter a descriptive 'Title' and brief Description for the lead training project and/or program proposed for funding from any Grant which may be awarded pursuant to this application.</i>	
3	(Title)	(Description)
	Which statement best describes the above proposed project and/or program? <i>check <input checked="" type="checkbox"/> one</i>	
	<input type="checkbox"/> New	<input type="checkbox"/> Change to existing <input type="checkbox"/> Continuing
	Which statement best describes how many <u>training programs</u> may benefit from the proposal? <i>check <input checked="" type="checkbox"/> one</i>	
	<input type="checkbox"/> Multiple Programs	<input type="checkbox"/> Single Program
	Describe the impact on training if this Grant is not awarded, or check <input checked="" type="checkbox"/>	
		No Significant Impact

D	<i>Enter a descriptive 'Title' and brief Description for the lead training project and/or program proposed for funding from any Grant which may be awarded pursuant to this application.</i>	
4	(Title)	(Description)
	Which statement best describes the above proposed project and/or program? <i>check <input checked="" type="checkbox"/> one</i>	
	<input type="checkbox"/> New	<input type="checkbox"/> Change to existing <input type="checkbox"/> Continuing
	Which statement best describes how many <u>training programs</u> may benefit from the proposal? <i>check <input checked="" type="checkbox"/> one</i>	
	<input type="checkbox"/> Multiple Programs	<input type="checkbox"/> Single Program
	Describe the impact on training if this Grant is not awarded, or check <input checked="" type="checkbox"/>	
		No Significant Impact

Be sure that if this continuation work sheet is used, your application is both properly marked and this sheet is included with your application filing.

FEB 26 2016

Continuation Sheet E - Side 1

E In the below table itemize in priority order – starting with the most needed first, ALL items of “Goods” (e.g. equipment, hardware or other durable items) or categories of “Services” which are to be funded in whole or in part from any Grant which may be awarded pursuant to this application.

Enter Project Number from [D] above	Check <input checked="" type="checkbox"/> One	Description	Total Cost	Less any Matching Funds	Grant Amount Requested
6	<input type="checkbox"/> Goods		(a)	(b)	(a-b)
	<input type="checkbox"/> Services		\$ -	\$ -	\$ -
7	<input type="checkbox"/> Goods		(a)	(b)	(a-b)
	<input type="checkbox"/> Services		\$ -	\$ -	\$ -
8	<input type="checkbox"/> Goods		(a)	(b)	(a-b)
	<input type="checkbox"/> Services		\$ -	\$ -	\$ -
9	<input type="checkbox"/> Goods		(a)	(b)	(a-b)
	<input type="checkbox"/> Services		\$ -	\$ -	\$ -
10	<input type="checkbox"/> Goods		(a)	(b)	(a-b)
	<input type="checkbox"/> Services		\$ -	\$ -	\$ -
11	<input type="checkbox"/> Goods		(a)	(b)	(a-b)
	<input type="checkbox"/> Services		\$ -	\$ -	\$ -
12	<input type="checkbox"/> Goods		(a)	(b)	(a-b)
	<input type="checkbox"/> Services		\$ -	\$ -	\$ -

Be sure that the total of ALL “Grant Amount Requested” entries are properly accounted for in the final line of Section E of your application. Also, be sure that if this continuation work sheet is used, your application is both properly marked and this sheet is included with your filing of the application.

Continuation Sheet E - Side 2

	<input type="checkbox"/> Goods		(a)	(b)	(a-b)
--	--------------------------------	--	-----	-----	-------

MEMORANDUM OF AGREEMENT

This Memorandum of Agreement is hereby made and entered into this 31st day of March, 19 99 with Roanoke County ("County") the City of Roanoke ("City"), City of Salem ("Salem") and Town of Vinton ("Town"), Virginia, and for identification shall be hereinafter referred to collectively as "Partners".

WHEREAS, the undersigned political subdivisions which are parties to the Agreement are desirous of maximizing the training of fire, emergency medical personnel by combining resources and making the most efficient use of training staff; and

WHEREAS, it is desirable that each of the parties hereto should voluntarily aid and assist each other in the training of fire and emergency medical personnel; and

WHEREAS, none of the parties hereto currently has a suitable facility for conducting on-going fire training academies and related classes; and

WHEREAS, all parties hereto desire to combine potential resources to construct a regional fire training academy for the use and good of all parties; and

WHEREAS, County owns appropriate land identified in the attached plat (Appendix B) in Roanoke County suitable for the development of a cooperative fire training facility which land and existing improvements shall be used by the Partners for purposes of this Agreement; and

WHEREAS, partner jurisdictions have capital funds available to begin development of a cooperative fire training facility.

NOW, THEREFORE it is hereby agreed by and between the parties hereto as follows;

The term "Regional Fire Training Building or Center" shall mean land, designated roadways leading immediately thereto, utilities, fire tower, training center, or other physical structures and facilities located on property used for the purpose of providing a fire training facility on property

heretofore identified and used for the purpose of providing a fire training facility.

The Center shall be under the joint direction and supervision of a training governing committee ("Committee") consisting of representatives appointed by the Fire Chiefs of the Partners.

SPECIFIC PROVISIONS

1. County shall make available suitable land heretofore identified at the Kessler Mill Site in Roanoke County to be developed as a regional training center. County shall retain ownership of the land and improvements throughout the term of this agreement. The Cities of Roanoke and Salem and Town hereby authorizes the County to make all applications on their behalf related to zoning and any required permits for this project.
2. County has prepared a draft site plan that provides general dimensions of the training center and includes proposed building location with draft architectural drawings. The draft site plan and drawings are incorporated into and made a part of this agreement as depicted in Appendix C.
3. Costs of utilities shall be born by the committee which shall provide for such costs in its annual operations budget.
4. County will, as expeditiously as possible, take all actions necessary thereafter to obtain all required zoning, special use and building permits. County will act on behalf of the Partners and be the lead agent in bidding and procuring an architect and builder of the center. Cost will be allocated to each Partner in accordance with the formula set forth in Appendix A
5. The committee will be responsible for administration and coordination of the Center's use.
6. County will coordinate utilities, trash removal and routine center maintenance which shall be provided at the level currently provided at other Roanoke County facilities.
7. In so far as permitted by law, each party agrees that, as between the parties, it shall be

responsible for its agents' acts and employees' acts and omissions within the scope of their duties which cause injury to persons or property including any violation of any environmental or other responsibility imposed by statute or regulation directly resulting from their use of the Center. Notwithstanding the above, none of the Partners shall be responsible for punitive damages assessed against its employees or agents or for its employees or agents criminal conduct. Nothing herein shall be deemed as a waiver of sovereign immunity or any other defense available to the Partners.

The provisions of this agreement are for the sole benefit of the parties, and no other person or entity shall be entitled to enforcement of any parts of this agreement.

MUTUAL OBLIGATIONS

1. The Partners agree to provide contributions of assets or funds as identified in Appendix A for the construction of and improvements to the Center. Once the Center is initially completed, the Partners will contribute funds contingent upon budgetary approval by the Partners in pro-rated parts toward the operating and routine maintenance expenses of the Center based upon the formula in Appendix A.
2. The initial Center improvements shall include the following: an office and instructional building of new construction of approximately 15,400 square feet.
3. The Partners agree that the construction of and improvements to the Center will comply with all state laws and county code provisions and the directions of the Committee. The Roanoke County Purchasing Department will handle the procurement of all construction services, materials and supplies for the construction of and improvements to the Center upon written direction of the Committee by its Chair as provided in paragraph 5 below.
4. The Roanoke County Finance Department will process all invoices for payment for these

materials and supplies and will bill the Partners on a quarterly basis in accordance with the terms of this agreement for all expenses, services and operating costs associated with the Center as approved by the Committee.

5. The Center will be under the jurisdiction and supervision of the Committee. The Committee will consist of eight (8) members appointed as follows:

Chair: The Chair shall be a member of the Committee who shall have all rights of membership including the right to vote. The Chair shall rotate each calendar year between the jurisdictions in the following order: County Fire-Rescue Chief or his designee; City Fire-EMS Chief or his designee; Salem Fire Chief or his designee.

Members County (3): Fire Chief, Training Officer, appointee of Fire Chief

City (3): Fire Chief, Training Officer, appointee of Fire Chief

Salem (1): Chief or designee.

Town(1): Designee

6. The Committee shall adopt and be governed by bylaws which shall be subject to approval by the Chiefs of both the City and County. Such bylaws shall include the following components:

1. Quorum. Five (5), which can be made up of members from any of the four departments. In order for the Committee to approve any formal action, if fewer than five affirmative votes are received, there must be at least one affirmative vote from a representative of three of the Partners.
2. Meeting Schedule. To be held at least quarterly.
3. Notice of Meetings. Five working days unless waived in writing by all members.
4. Scheduling/Use. To be determined by the Committee and incorporated in the bylaws or published rules.

7. With the objective of insuring safe operation of the Center, the Committee shall govern the use of the Center. Subject to the terms and conditions of this memorandum of agreement, the Committee shall have absolute discretion to refuse permission for the use of the Center or to establish such conditions for its use as the Committee shall deem necessary.
8. Each respective political subdivision shall have control over their employees. Employees will be under the rules and regulations of their employers.
9. This Agreement shall not be construed to impair or affect any sovereign or governmental or official immunities that may otherwise be available to the City and County of Roanoke, Salem and Vinton, any of its officers, agents or employees. Any legal liability which may be imposed upon any partner by a court of competent jurisdiction or by duly authorized settlement of any legal claim against any jurisdiction shall be retained by such party hereto for the conduct of its own employees and for such invitees as each may authorize to use or be present on the premises of the Center. In the event of a third party liability claim not covered by this paragraph, the City of Roanoke, Roanoke County, the City of Salem and Town of Vinton shall share in the proportions set forth in Appendix A in all costs of defense and in any monetary judgment or settlement of such claim, unless otherwise mutually agreed to between the parties.
10. Each partner shall be responsible for worker's compensation liability for their respective employees who may suffer compensable injuries arising out of their use of or authorized presence at the Center.
11. Snow removal decisions shall be made by the Committee and necessary costs for such will be shared by the parties hereto according to Appendix A, cost sharing formula.
12. Annual operating costs and maintenance of the Center:

- A. The Committee shall adopt an annual operating and maintenance budget for the Center and shall submit such budget to the City and County, Salem and Vinton budget offices by December 15 of each year. Operating costs shall be pro-rated as outlined in the cost sharing formula of Appendix A.
- B. The County Fire-Rescue Chief or his designee will prepare an itemized invoice and forward to the other Partners on a quarterly billing (September 30, December 31, March 31 and June 30) for the actual cost of operating and maintaining the Center. Within 30 days, the Partners shall approve and forward for payment.
13. It is the intent of the Partners of this agreement to have a twenty-five year (25) term. This agreement can be renewed on a five (5) year recurring basis with approval of the remaining Partners.
14. Any Partner may indicate its desire to terminate this agreement by providing written notice to the chief governing officer of the other Partners at least two (2) years in advance of such termination. Within thirty (30) days upon receipt of such written notice to terminate, the receiving jurisdiction may request the initiation of mediation or other non-binding alternative dispute resolution (ADR) proceedings. Such a request for ADR proceeding shall operate as a stay of any termination until the completion of any such proceedings pursued in good faith. In the event of termination, each Partner which is to no longer have an interest in the Partnership will be reimbursed by the remaining Partners for the value of the improvements and equipment for which such Partner has been invoiced and has paid as part of construction of the offices and training center complex but reduced in value on a straight line depreciation calculation but not to exceed a twenty-five (25) year calculation period. Ownership of any Partner's personal property which has not been formally transferred to the Committee shall

be retained by the Partner and may be removed from the Center site at termination. The County shall retain ownership of the site and shall have and receive ownership of all fixtures, personal property and equipment and other assets of the Committee. Each Partner shall execute any quit claim deeds, bills of sales or conveyances reasonably requested by the County to evidence the County's ownership of all assets formerly owned or controlled by the Committee.

15. The Partners which retain an interest in the Center shall pay the exiting jurisdiction any amount established in accordance with paragraph 14 above within ninety (90) days from the termination date of this agreement.

Attest:

Mary J. Parson
City Clerk

W. Robert Herbert
W. Robert Herbert, City Manager, Roanoke City

4/9/99
Date

Approved as to Form:

William Plummer
City Attorney

Approved as to Execution:

City Attorney

Appropriation and Funds Required for
this Contract Certified

D. Allen
Director of Finance

3-31-99 008-052-9718
Date Acct. #

Anchor Sales and Service, Inc.

1425 Lynchburg Turnpike
Salem, VA 24153

(540) 389-4366

Quote

Customer No.: RKE FIRE-EMS

Quote No.: 2603

Quote To: **RKE FIRE-EMS DEPARTMENT**

713 THIRD ST. SW
ROANOKE, VA 24016

Ship To: **RKE FIRE-EMS DEPARTMENT**

713 THIRD ST. SW
ROANOKE, VA 24016

(540) 853-1207

Date	Ship Via	F.O.B.	Terms		
02/18/16		Origin	C.O.D.		
Purchase Order Number		Sales Person			
		BH			
		Required			
		02/18/16			
Quantity			Unit Price	Amount	
Required	Shipped	B.O.	Item Number	Description	
1			47408	8.5 X 20 HERCULES TRAILER WHITE WITH 7'8" INT. HT. RAMP DOOR REAR WITH 32" SIDE DOOR AND 24" STONE GUARD WITH VNOSE SIDE FLOW THRU VENTS 9950 GVWR WITH RADIAL TIRES AND LED LIGHTS	
				6299.00	6299.00

Quote subtotal 6299.00
Quote total 6299.00

Thank You



Roanoke Fire-EMS Department
Training

Date: February 23, 2016

To: VDFP Grants & Local Aid Manager

From: Roanoke Valley Regional Fire-EMS Training Center Partners

Subject: 2016 VDFP Training Grant

Roanoke Fire-EMS, Roanoke County Fire & Rescue and Salem Fire-EMS are requesting funding totaling \$15,000 to purchase a trailer and training tools for our Regional Fire-EMS Training Center. These funds will be used to purchase a mobile trailer along with tools to be housed inside the trailer which are outlined in our grant application.

Our Training Academy puts on one to two Regional Recruit Schools each year. Currently we do not have a trailer that can safely transport tools/props to mobile training scenarios during these schools. If we are granted this funding, we can ensure that we are training in the safest manner possible. These tools will also be used to train department members.

We appreciate your consideration for this funding. If you have any questions, please contact Tiffany Bradbury at 540-853-5785 or tiffany.bradbury@roanokeva.gov.

Administration

FEB 26 2016

Department of Fire Programs



General Instructions & Notices

- Applicants are directed to "**Regional Fire Services Training Facilities Grant Program Policy**" as amended for the current funding year which is incorporated by reference to all applications and any subsequent awards. (Such practices document is inclusive of all *terms & conditions*.)
- The filing of an application does not bind the Board to award nor the Department to pay any such grant.
- Incomplete applications and those received after the deadline will not be considered.
(Deadline) → **March 1, 2016** postmarked
- Completed applications executed by the competent authority will only be accepted directly from jurisdictions not fire departments.
- Timeliness of filing and subsequent receipt by the Agency are solely the applicant's responsibility – all applications must be completed in ink and sent directly to: **VDFP Grants and Local Aid Manager,**
Address → 1005 Technology Park Drive, Glen Allen VA 23059-4500
- All decisions regarding grant awards made by the Board are final; applicants may appeal decisions in writing to the address provided above within 15 business days of the posting of awards.

A. Applicant Information

1. Title of Lead Jurisdiction Making Application (Check <input checked="" type="checkbox"/> only one, then make entry)	<input checked="" type="checkbox"/> County of <u>Spotsylvania</u>
	<input type="checkbox"/> City of _____
	<input type="checkbox"/> Incorporated Town of _____
2. Employer Identification Number (EIN)	[REDACTED]
3. Principal Point of Contact	(Include salutation, name & title.) Lieutenant Stephen Wise
4. Mailing Address (Include zip code) Identify COUNTY if appropriate	P.O. Box 818 Spotsylvania, VA 22553 Spotsylvania County
5. Telephone Number	(540) 507-7921
6. FAX Number	(540) 582-6957
7. Internet e-mail address	<u>spwise@spotsylvania.va.us</u>

B. Additional Parties

	Identify ALL jurisdictions (Not Fire Departments) participating in the proposed project. Attach additional sheets as may be required.
1. Formal Agreement Among Parties	<p>In accordance with Program Policy, multi-jurisdictional regional training partnerships must be documented (e.g. MOA, MOU, etc.) as required supporting documentation to the Application for consideration of Program funding.</p> <p>A copy of the Agreement has been attached to this application. <input checked="" type="checkbox"/> Yes <input type="checkbox"/> No</p> <p><i>If a copy of the Agreement has not been attached as required supporting documentation, this Application will be considered incomplete and funding will not be approved.</i></p>

Department of Fire Programs

FEB 29 2013

Administration



(Reproduce and complete as many additional blocs as may be necessary for complete disclosure.)

2a. Complete <u>one each</u> for ALL other Parties of Interest	Number <u>2</u> of a total of <u>3</u> parties to proposed project <small>(Count the LEAD Locality as #1, thereby start with #2.)</small>
2b. Title of Jurisdiction <small>(Check <input checked="" type="checkbox"/> only one, then make entry)</small>	<input type="checkbox"/> County of _____
	<input checked="" type="checkbox"/> City of <u>Fredericksburg</u>
	<input type="checkbox"/> Incorporated Town of _____
2c. Employer Identification Number (EIN)	[REDACTED]
2d. Principal Point of Contact	<small>(Include salutation, name & title.)</small> Fire Chief Edwin L. Allen, Jr.
2e. Mailing Address <small>Identify COUNTY if appropriate -</small>	<small>(Include zip code+4)</small> 601 Caroline Street, Suite 700 Fredericksburg, VA 22401
2f. Telephone Number	(540) 540-372-1059
2g. FAX Number	(540) 540-372-1050
2h. Internet e-mail address	eallen@fd.fredericksburgva.gov

Department of Fire Programs
 FEB 29 2016
 Administration

(Reproduce and complete as many additional blocs as may be necessary for complete disclosure.)

2a. Complete <u>one each</u> for ALL other Parties of Interest	Number <u>3</u> of a total of <u>3</u> parties to proposed project <small>(Count the LEAD Locality as #1, thereby start with #2.)</small>
2b. Title of Jurisdiction <small>(Check <input checked="" type="checkbox"/> only one, then make entry)</small>	<input checked="" type="checkbox"/> County of <u>King George</u>
	<input type="checkbox"/> City of _____
	<input type="checkbox"/> Incorporated Town of _____
2c. Employer Identification Number (EIN)	[REDACTED]
2d. Principal Point of Contact	<small>(Include salutation, name & title.)</small> Fire/Rescue Chief David W. Moody
2e. Mailing Address <small>Identify COUNTY if appropriate -</small>	<small>(Include zip code+4)</small> 8122 Kings Highway King George, VA 22485 <u>King George</u>
2f. Telephone Number	(540) 540-775-8900
2g. FAX Number	(540) 540-775-9060
2h. Internet e-mail address	davidm@co.kinggeorge.state.va.us

(Reproduce and complete as many additional blocs as may be necessary for complete disclosure.)

2a. Complete <u>one each</u> for ALL other Parties of Interest	Number <u> </u> of a total of <u> </u> parties to proposed project <small>(Count the LEAD Locality as #1, thereby start with #2.)</small>
2b. Title of Jurisdiction <small>(Check <input checked="" type="checkbox"/> only one, then make entry)</small>	<input type="checkbox"/> County of _____
	<input type="checkbox"/> City of _____
	<input type="checkbox"/> Incorporated Town of _____
2c. Employer Identification Number (EIN)	[REDACTED]
2d. Principal Point of Contact	<small>(Include salutation, name & title.)</small>
2e. Mailing Address <small>Identify COUNTY if appropriate -</small>	<small>(Include zip code+4)</small>
2f. Telephone Number	()
2g. FAX Number	()
2h. Internet e-mail address	



C. Previous Applications/Awards

1.	Has the Applicant previously applied for a RFSTF Grant from the Board? - check <input checked="" type="checkbox"/> one	<input type="checkbox"/> No	<input checked="" type="checkbox"/> Yes
2.	Has the Applicant previously received a RFSTF Grant from the Board? - check <input checked="" type="checkbox"/> one	<input type="checkbox"/> No	<input checked="" type="checkbox"/> Yes

D. Project Title(s) and Description(s)

Enter a descriptive 'Title' and brief 'Description' for the lead training project and/or program proposed for funding from any Grant which may be awarded pursuant to this application.

1	(Project Title) Rappahannock Regional Fire Training Center's Flashover Simulator	(Description) A flashover simulator will provide a safe yet realistic way to train the firefighters utilizing the Rappahannock Regional Fire Training Center. Recognizing the indicators of a potential flashover is imperative to the safety and survival of a firefighter.
Which statement best describes the above proposed project and/or program? check <input checked="" type="checkbox"/> one		<input checked="" type="checkbox"/> New <input type="checkbox"/> Change to existing <input type="checkbox"/> Continuing
Which statement best describes how many training programs may benefit from the proposal? check <input checked="" type="checkbox"/> one		<input checked="" type="checkbox"/> Multiple Programs <input type="checkbox"/> Single Program
Describe the impact on training if this Grant is not awarded, or check <input type="checkbox"/> No Significant Impact		
If the grant request is not approved, the regional partners will continue to lack the ability to efficiently train firefighters in this area or be required to send personnel to other areas within the state to receive this type of training. Sending employees to other jurisdictions results in manpower shortages and increased costs to pay for overtime and associated travel costs for the regional partners		
<input type="checkbox"/> Check <input checked="" type="checkbox"/> IF a Continuation D Sheet is used to account for more than one (1) project / program.		
IMPORTANT, if box above is checked and no continuation sheets are attached, the application will not be further considered.		

E. Project Goods & Services Requested

In the below table, itemize in priority order – starting with the most needed first, ALL items of "Goods" (e.g. equipment, hardware or other durable items) or categories of "Services" which are to be funded in whole or in part from any Grant which may be awarded pursuant to this application.

Enter Project Title from [D] above	Check <input checked="" type="checkbox"/> One	Description	Total Cost	Less any Matching Funds	Grant Amount Requested
1	<input checked="" type="checkbox"/> Goods	Flashover simulator: This price includes the burn room with corresponding crib to build the seat of the fire, train-the-trainer instructional program, and shipping.	(a) \$ 47,500.00	(b) \$ -	(a-b) \$ 47,500.00
2	<input checked="" type="checkbox"/> Services	Concrete pad: This price includes labor, materials, and equipment to furnish and install the concrete pad for the flashover simulator.	(a) \$ 4,400.00	(b) \$ 1,900.00	(a-b) \$ 2,500.00
3	<input type="checkbox"/> Goods		(a) \$ -	(b) \$ -	(a-b) \$ -
4	<input type="checkbox"/> Services		(a) \$ -	(b) \$ -	(a-b) \$ -
5	<input type="checkbox"/> Goods		(a) \$ -	(b) \$ -	(a-b) \$ -

Check IF a Continuation D Sheet is used to account for more than one (1) project / program.
IMPORTANT, if box above is checked and no continuation sheets are attached, the application will not be further considered.

E	Enter here the lesser amount of: • Sum of all items (1 thru n) under "Grant Amount Requested" • OR \$50,000 (Grant maximum)	\$ 50,000.00
---	---	---------------------



F. Matching/Cost Share

1	Which statement best describes the matching funds contributions? <i>check <input checked="" type="checkbox"/> one</i>	<input type="checkbox"/> 50% or More	<input checked="" type="checkbox"/> Less than 50%	<input type="checkbox"/> None
---	--	--------------------------------------	---	-------------------------------

G. ATL Funding

1	What is the amount of the Applicant's FY-2015 Aid to Localities (ATL) allocation from the Fire Programs Fund? <i>check <input checked="" type="checkbox"/> one and complete as necessary</i>	<input type="checkbox"/> \$10,000 or \$20,000 exactly	<input checked="" type="checkbox"/> Other - Enter amount here	\$ 232,662.60
2	Did the Applicant have cash carry forward from FY-2015 into FY-2016 from previous years' Aid to Localities (ATL) allocations? <i>check <input checked="" type="checkbox"/> one and complete as necessary</i>	<input checked="" type="checkbox"/> Yes	<input type="checkbox"/> No	If "Yes", amount of FY-2015 ATL carry forward: \$554,247.72

Remarks	Make entries or check <input checked="" type="checkbox"/> <input type="checkbox"/> None	Important - If the sum (1 to n) of individual "Grant Amount. Requested" in E above exceeded \$50,000, an explanation must be entered here as to how the shortfall would otherwise be made up.
	The Department of Fire, Rescue, and Emergency Management proposes to use their annual Aid to Locality-State Fire Programs funding to cover the \$1,900 difference.	

EFT (EDI)

Grant awards are paid as an **Electronic Funds Transfer / EDI** to the current *account-of-record* for the jurisdiction's annual allocation of Aid to Localities (ATL) from the Fire Programs Fund.

Certification:

To be completed by either:

- County Administrator –or- Executive, City Manager, Town Mayor –or- Administrator; Deputy, or...
- Other duly authorized official whereby the application is accompanied by a copy of an 'Ordinance' or other such formal instrument clearly granting that party such authority.

This grant application is entered on behalf of the APPLICANT jurisdiction identified above with the knowledge and belief that all representations herein made are true and correct; with the understanding that all grant terms & conditions in-force as of the date of such application are hereby included by reference; with the further understanding that if an award is granted pursuant to this application that the recipient is bound by those same terms & conditions.

	2/25/16
Signature	Date
Mark B. Taylor	County Administrator
Printed Name	Title

(All applications must be notarized to be considered - incomplete forms shall be returned.)

State of Virginia }
City / County of Spotsylvania }

On this 25th day of February (month) in 2016 (year), before me, the undersigned a Notary Public for the Commonwealth of Virginia, personally appeared Mark B. Taylor to me known (or to me proved) to be the identical person named herein and having in my presence executed the above, and acknowledged that he executed same as his voluntary act and deed.

My Commission expires: 8-31-16 Date

NADERA M GREENE
Notary Public
Commonwealth of Virginia
7206352
My Commission Expires Aug 31, 2016

Administration

FEB 29 2016

Department of Fire Programs

REGIONAL FIRE AND EMS TRAINING CENTER AGREEMENT

THIS AGREEMENT, made and entered into this 1st day of November, 2006, by and between Spotsylvania County, City of Fredericksburg, and King George County, Virginia (“Partner Jurisdictions”), political subdivisions of the Commonwealth of Virginia.

WITNESSETH

WHEREAS, the undersigned Partner Jurisdictions, desire to improve the training of fire and emergency medical services (EMS) personnel by combining their resources and making the most efficient use of the training facilities and staff, and

WHEREAS, it is desirable that each of the Partner Jurisdictions voluntarily aid and assist each other in the training of fire and EMS personnel, and

WHEREAS, no single Partner Jurisdiction currently has a suitable facility for conducting ongoing fire and EMS training or classes nor the individual funds to support such facility, and

WHEREAS, the Partner Jurisdictions desire to combine their existing and future resources for the purpose of purchasing a tract of land and constructing and operating a regional fire and EMS training center (“Fire and EMS Training Center”) for the use and benefit of the Partner Jurisdictions, and, when appropriate, other jurisdictions;

NOW, THEREFORE, by mutual consent of the Partner Jurisdictions, and pursuant to the authority granted to them by section 15.2-1300 of the Code of Virginia, 1950, as amended, it is hereby agreed by and among the Partner Jurisdictions as follows:

1. **Definitions.** The following words, terms, and phrases, when used in this Agreement, shall have the meanings ascribed to them in this Paragraph, except where the content clearly indicates a different meaning:

“*Agents*” shall mean and include authorized officers, employees, and agents of a Partner Jurisdiction.

“*Agreement*” shall mean this Agreement, as may be amended from time to time by mutual consent of the governing bodies of each Partner Jurisdiction.

“*Commission*” shall mean the governing body of the Rappahannock Regional Fire and EMS Training Center Commission, as established by this Agreement.

“*Fire and EMS Training Center*” or “*Center*” shall mean the land, the designated roadways leading immediately thereto, utilities, fire tower, training center, and other physical structures

and facilities located thereon and used for the purpose of providing a regional fire and EMS training facility.

“*Partner Jurisdictions*” shall mean, initially, the City of Fredericksburg, King George County, and Spotsylvania County, and thereafter any other jurisdiction that becomes a party to this Agreement

2. **Commission Created.** The parties hereby create and establish a regional body to be known as the Rappahannock Regional Fire and EMS Training Commission.

3. **Purpose and Authority.** The Commission is created pursuant to Virginia Code section 15.2-1300 for the sole purpose of jointly exercising the Partner Jurisdictions’ respective powers regarding the purchasing of land, construction, operation, maintenance, expansion, and alternation of a Fire and EMS Training Center, which shall be operated primarily for the benefit of the citizens of the Partner Jurisdictions. The Commission shall be limited to those powers expressly set forth herein.

4. **Term.** This Agreement and the Commission created hereby shall be in full force and effect from the date hereof for a period of twenty five (25) years (initial term) and shall renew upon approval of the governing bodies of each partner jurisdiction for five (5) year terms thereafter unless a partner jurisdiction shall give notice of its intent to terminate its association with the commission , or in the event the Commission is dissolved pursuant to Paragraph 13 below.

5. **Membership; Terms of Office.** The Commission shall consist of six (6) members, of whom the governing body of each Partner Jurisdiction shall appoint two (2) members. Each member shall be appointed to serve a four (4) year term of office. Members shall continue to serve until their successors qualify and assume office.

6. **Chair; Rules of Procedure.**

(a) The Commission shall select annually one of its members to serve as the chair, who shall maintain full membership rights, including the right to vote. The Commission shall select annually another of its members from a different Partner Jurisdiction to serve as the Vice-Chair, who shall preside in the absence of the Chair. No Partner Jurisdiction shall hold the Chair for more than two (2) consecutive years.

(b) The Commission shall not take any official action without the presence of a quorum, which shall consist of four (4) members representing a majority of the Partner Jurisdictions.

(c) The Commission shall adopt and be governed by such bylaws consistent with this Agreement and by Robert's Rules of Order.

7. **Powers of the Commission.** The Commission shall enjoy and exercise day-to-day operational control over the purchasing of land, construction, operation, and maintenance of the Fire and EMS Training Center. Specifically, the Commission shall have the power to:

- (i) Select a site in Spotsylvania County for the Fire and EMS Training Center.
- (ii) To approve the design of any buildings, roads, or other improvements located on said property and to submit zoning, site plan, and other necessary land use applications to the jurisdiction(s) in which the Fire and EMS Training Center is to be located. Such plans and applications shall be subject to the review and the approval of Spotsylvania County.
- (iii) To purchase and hold title to, sell, lease, encumber, or otherwise acquire or dispose of all or part of the real property on which the Fire and EMS Training Center is to be located; provided, however, that any deed, lease, easement, or other transaction entered into by the Commission involving such real property shall be subject to the unanimous approval of the governing bodies of the four (4) initial Partner Jurisdictions.
- (iv) To enter into contracts, to sue and be sued, and to receive gifts, bequests, and donations of property for the benefit of the Commission and the Fire and EMS Training Center.
- (v) To enter into cooperative procurements or other agreements with any Partner Jurisdiction in order to purchase goods and services or to undertake construction activities on a more cost-effective basis.

8. **Initial Capital Contributions.** The initial Partner Jurisdictions shall make the following initial capital contributions toward the cost of purchasing the property on which the Fire and EMS Training Center is to be located and constructing all improvements related thereto, including roads and utilities:

Each initial Partner Jurisdiction shall be responsible for 33 1/3% of the initial capital contribution not to exceed \$200,000.00 per jurisdiction and \$600,000.00 total.

Such contributions shall be contingent upon the Commission receiving a regional grant from the Virginia Department of Fire Programs for construction in the amount of approximately Four Hundred Thirty Thousand Dollars (\$430,000.00).

9. **Fiscal Agent.** Spotsylvania County shall serve initially as the fiscal agent for the Commission, but the Commission shall have the authority to enter into an agreement with any Partner Jurisdiction to provide such services in the future.

10. **Initial Capital Budget.** Prior to the construction of the Fire and EMS Training Center, the Commission shall submit a Capital Budget therefore to the chief administrators of the Partner Jurisdictions for approval. Once such Capital has been approved, the Commission shall not approve any change order in the contract(s) for construction that will result in expenditures in excess of said Capital Budget without the unanimous approval of the three (3) chief administrators.

11. **Annual Operating Budget.**

(a) The Commission shall prepare and submit an annual operating budget for the Fire and EMS Training Center to the Partner Jurisdictions no later than November 1 of each year. The Partner Jurisdictions shall be responsible for paying an equal share of such annual budget, except that the cost of natural or propane gas used for training burns and other operational costs and supplies attributable solely to use of the Center by one of the Partner Jurisdictions shall be paid by that particular locality. The Commission shall prepare and submit to each locality a quarterly report outlining the actual operational usage of the center by each Partner Jurisdiction. The Commission shall prepare and submit to each of the Partner Jurisdictions an annual report no later than September 1 of each year. The annual report shall present information about the prior fiscal year's (July 1-June 30) operation of the Center. The annual report shall include information about the Center's finances, usage by Partner Jurisdictions and outside agencies, operational issues, planned future capital needs, and such other information as may be appropriate. The chief administrator of a Partner Jurisdiction may request that representatives of the Commission present the annual report to the respective governing bodies.

(b) The Commission shall charge outside agencies (fire and/or EMS agencies from outside the Partner Jurisdictions) for use of the Center at such rates as may periodically be set by the Commission. Revenue derived from such outside agencies shall be credited equally to the Partner Jurisdictions in the annual operating budget.

(c) In the event that the governing body of any Partner Jurisdiction fails or refuses to approve the annual operating budget of the Commission, the Commission shall reconsider its proposed budget and re-submit it to the Partner Jurisdiction for approval. If any locality still fails or refuses to approve such budget, the Partner Jurisdictions shall enter into non-binding mediation to resolve their differences.

12. Insurance and Liability.

(a) The Commission shall secure and maintain appropriate levels of casualty and public liability insurance coverage for the Center through policies issued in the name of the Commission.

(b) Insofar as permitted by law, each party agrees that, as among the Partner Jurisdictions, each locality shall be responsible for the acts and omissions of its own employees and agents acting within the scope of their duties that cause injury to persons or property, including any violation of environmental or other responsibilities imposed by local, state, or federal law, ordinance, or regulation, directly resulting from such jurisdiction's use of the Center. The cost of repair or replacement of any damage to equipment, fixtures, or structures at the Center resulting from the negligent use thereof or the willful destruction of same by the employees employed by, and/or volunteers acting under the responsibility of one or more Partner Jurisdictions using the Center shall be borne by those jurisdictions using the Center at the time such damage occurred.

(c) Nothing herein shall be deemed a waiver of sovereign immunity or any other defense otherwise available to the Partner Jurisdictions, collectively or individually. The provisions of this Agreement are for the sole benefit of the parties hereto and no other person or entity shall be entitled to enforcement of any part hereof.

(d) Each Partner Jurisdiction shall be responsible for worker's compensation liability and other insurance coverage for their respective employees who may suffer compensable injuries arising out of their use of or their authorized presence at the Center.

(e) The Commission shall require all outside agencies or persons using the Center to present written proof of valid accident insurance prior to their use thereof.

13. **Termination and Dissolution.**

(a) Any Partner Jurisdiction may indicate its desire to terminate this Agreement and to withdraw from the Commission by providing written notice thereof to the chief administrator of the Partner Jurisdictions at least two (2) years in advance of the intended termination date. Within thirty (30) days of receipt of such written notice, any other Partner Jurisdiction may request the initiation of non-binding mediation to address the reasons for termination. Such a request for mediation shall operate as a stay of any termination until the completion of any such proceedings pursued in good faith.

(b) In the event of termination, the terminating jurisdiction shall automatically forfeit all of its interest in any real and personal property owned by the Commission. Such terminating jurisdiction shall be reimbursed by the remaining Partner Jurisdictions for its share of such property, in an amount equal to (1) the terminating jurisdiction's initial capital contribution, as set forth above in Paragraph 8, and (2) its share of the cost of any other capital improvements and equipment actually paid for by such jurisdiction, less straight-line depreciation for the number of years such improvements and equipment have been in use by the Commission. Such terminating jurisdiction, however, shall remain liable for its share of any debt or liabilities incurred by the Commission prior to the effective date of termination.

(c) Upon the expiration of this Agreement or upon the unanimous agreement of the Partner Jurisdictions to dissolve the Commission and this Agreement, the Fire and EMS Training Center site shall be sold at fair market value and the proceeds distributed to the initial Partner Jurisdictions according to the percentage of the Capital Contributions set forth in Paragraph 8 above. The initial Partner Jurisdictions agree to execute any quitclaim deeds, bills of sale, or other documents necessary to effectuate such sale. All equipment, cash, and other personal property owned by the Commission at the time of expiration or dissolution of this Agreement shall be divided equally among all of the Partner Jurisdiction.

14. **Legal Counsel.** The Commission shall retain outside legal counsel to advise it on legal matters affecting the Commission and the Fire and EMS Training Center.

15. **Miscellaneous.**

(a) This Agreement shall be effective as of the date it is ratified by the governing bodies of the initial Partner Jurisdictions.

(b) The parties agree that the construction, operation, and maintenance of the Fire and EMS Training Center shall comply with all applicable local ordinances of the host jurisdiction where the Center is located and with all other applicable local, state, and federal laws and regulations.

(c) This Agreement may be amended only by written amendment of equal dignity hereto and approved by resolution of the governing body of each Partner Jurisdiction. This shall include the addition of any new Partner Jurisdictions.

(d) If any court of competent jurisdiction holds any provision of this Agreement invalid or unenforceable, such holding shall not affect the remaining provisions hereof.

16. **Authority.** This agreement is executed by the undersigned pursuant to the following:

IN WITNESS THEREOF, the parties have caused this Agreement to be executed as of the date above written:

CITY OF FREDERICKSBURG

COUNTY OF KING GEORGE

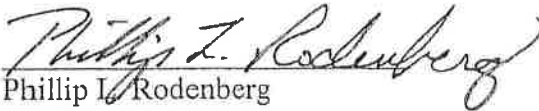
By: 
Phillip L. Rodenberg
City Manager

By: 
R. Bryan David
County Administrator

COUNTY OF SPOTSYLVANIA

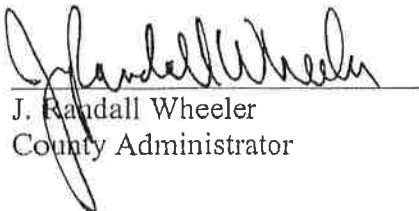
By: 
J. Randall Wheeler
County Administrator

APPROVED AS TO FORM:

APPROVED AS TO FORM:

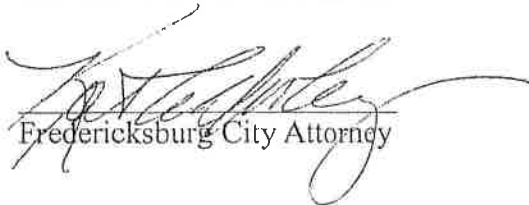
Fredericksburg City Attorney

Spotsylvania County Attorney

King George County Attorney

There has been a steady change in the residential fire environment over the past several decades. These changes include larger homes, different home geometries, increased synthetic fuel loads, and changing construction materials. Several experiments were conducted to compare the impact of changing fuel loads in residential houses. These experiments show living room fires have flashover times of less than five minutes when they used to be on the order of thirty minutes. Other experiments demonstrate the failure time of wall linings, windows, and interior doors have decreased over time which also impact fire growth and firefighter tactics. Each of these changes alone may not be significant but the all-encompassing effect of these components on residential fire behavior has changed the incidents that the fire service is responding to. This analysis examines the change in fire dynamics and the impact on firefighter response times and operational timeframes.

There is a continued tragic loss of firefighters' and civilian lives, as shown by fire statistics. One significant contributing factor is the lack of understanding of fire behavior in residential structures resulting from the changes that have taken place in several components of residential fire dynamics. The changing dynamics of residential fires as a result of the changes in home size, geometry, contents, and construction materials over the past 50 years add complexity to the fire behavior.

NFPA estimates that from 2003 to 2006, US fire departments responded to an average of 378,600 residential fires annually. These fires caused an estimated annual average of 2,850 civilian deaths and 13,090 civilian injuries. More than 70% of the reported home fires and 84% of the fatal home fire injuries occurred in one- or two- family dwellings, with the remainder in apartments or similar properties. For the 2001–2004 time period, there was an estimated annual average of 38,500 firefighter fire ground injuries in the US. The rate for traumatic firefighter deaths when occurring in outside structures or from cardiac arrest has declined, while at the same time, firefighter deaths' occurring inside structures has continued to climb over the past 30 years. Additionally, on average, firefighters in the United States receive less than 1% of their training on the subject of fire behavior. The changes in the residential fire environment combined with the lack of fire behavior training are significant factors that are contributing to the continued climb in firefighter traumatic deaths and injuries.

As homes become more energy efficient and fuel loads increase, fires will become ventilation limited making the introduction of air during a house fire extremely important. If ventilation is increased, either through the tactical action of firefighters or unplanned ventilation resulting from effects of the fire (e.g., failure of a window) or human action (e.g., door opened by a neighbor) heat release will increase, potentially resulting in flashover conditions. These ventilation induced fire conditions are sometimes unexpectedly swift, providing little time for firefighters to react and respond.

With a flashover simulator, the development of fire from the initial source of ignition to the break-out of smoke can be observed and the necessary behaviours and extinguishing types taught. The exercise follows a proven design. Before the exercise, the fire room is lined with chip board then an initial fire is ignited with fire wood. The intensity of the developing fire in the training system is controlled through the induction air flow by opening the access doors or operating the air valve. When a flash-over happens, the correct behaviour is life-saving. The trainees learn how to detect the signs of a flash-over here. Within the flash-over container temperatures of up to 650 °C develop near the top. Here the fire fighters can experience the heat of a real fire in safe conditions.

The Spotsylvania County Department of Fire, Rescue & Emergency Management meets as well as exceeds the basic training standards and elements of Firefighter I and Firefighter II as prescribed in NFPA 1001 and NFPA 1403.

The Training Division currently delivers the Firefighter I and II programs in an academy format for both paid and volunteer personnel. During this academy format, students go through Firefighter I and II, in addition to Hazardous Materials Operations, Mayday Awareness, Mayday Operations, Vehicle Rescue Operations and Introduction to Technical Rescue Module I.

The Training Division strives for excellence in all of its training programs by making sure that all instructors meet NFPA 1041, follow NFPA 1001, and the Virginia Department of Fire Programs guidelines. All fire service instructors utilize the provided lesson plans and Power Points and are strongly encouraged to enhance their classroom presentations with the addition of videos, pictures and personal experiences. To ensure that all fire service instructors know their responsibilities in delivering a program, the lead instructor of each respective program creates and distributes an incident action plan to each fire service instructor prior to any psychomotor or skills session. The incident action plan also helps to safeguard that all logistical needs, instructor / student ratios and NFPA 1403 compliance is met.

Upon the successful completion of the required hours for both the Firefighter I & II programs, the Spotsylvania County Training Division has built in several extra training days for the students to perform multi-company operations. These sessions provide a greater understanding of the tasks required to be performed on the fire ground prior to any structural live fire evolutions. This offers the student an opportunity to “put all the pieces together” that they have learned over the duration of the course in order to accomplish all the necessary functions of an engine and truck company.

In order to enrich the fire service training programs delivered in Spotsylvania County in conjunction with our regional partners, we have made numerous improvements to our regional fire/rescue training facility to include the following:

- purchase of extra ground ladders for ladder training,
- construction of a combination roof/vent prop for both forcible entry and ventilation training,
- utilization of numerous props that are used for SCBA training,
- purchase of forcible entry door prop, window prop and cutting prop for forcible entry training,
- construction of drums that are utilized for portable fire extinguisher training,
- construction of auto fire prop utilized for auto fire training,
- acquisition of a 500 gallon propane tank for flammable gas training,
- construction of additional Class A burn room for live fire training,
- acquisition of a dumpster to accomplish fire extinguishment in a trash container,

- installation of a set of metal steps in order to be able to go from the first landing of the burn building to the basement and vice versa without passing through the interior or walking completely around the outside of the building. These steps are utilized in numerous scenario based training exercises, and
- acquisition of an electrical breaker box and natural gas meter that is utilized for utility control training.

All of these components are completed because we understand how critical it is to prepare future firefighters for a safe and successful career as either a volunteer or career firefighter.



Dräger Safety Inc.

700 Second St, Ste G
Encinitas, CA 92024
U.S.A.
Tel.: 1 760 634-7740
Fax: 1 760 634-7746

Firm Proposal
Page: 1 of 2

Firm Proposal- PHASE 1 FLASHOVER SYSTEM

Offered Without Engagement To:

CUSTOMER:	Spotsylvania Fire Rescue and Emergency MGMNT	DATE:	1-19-2016
ADDRESS:	9119 Dean Ridings Lane	QUOTE #:	
CITY, STATE:	Spotsylvania, VA		
ZIP:	22553		
ATTENTION:	JH Bailey	PHONE:	540-507-7900
TITLE:		CELL:	
E-MAIL ADDRESS:			
REFERENCE:	Swede Phase 1 – Flashover Class A Prop	BDM:	
DELIVERY INFO:	Standard delivery is 60 days	RSM:	Dominic Colletti

Prices are firm to July 31, 2016

Item	Qty	Dräger Part #	Description	Unit Price	Extension
A	1	N/A	*Dräger Swede Survival Phase 1 -INCLUDES- (1) Burn room w/ corresponding crib (to build seat of fire) *Per PDF drawings provided – final engineering and design to be approved by customer before production	\$45,000.00	\$45,000.00
B	1	N/A	"Train-the-Trainer" Instructional Program	INCLUDED	INCLUDED
			➤ The training curriculum consist's of two parts: The first part is a two day, onsite training course for up to ten (10) of the department's instructors. The second part is a complete documentation package on operation and maintenance of the System.		
C	1	N/A	State Sales Tax		NOT INCLUDED
D		FREIGHT	Shipping to site		\$2,500
			➤ Total system to require (1) truckload to deliver ➤ Total Weight of 21,000lbs		
E		SET-UP	Phase 1 Product Set-up on site		NOT INCLUDED
			➤ See Phase 1 Technical Specification for details on set-up and site requirements ➤ Set-up can be provided at an additional cost		

Confidential and Proprietary
No release without written authorization from Dräger

Dräger Safety Inc.

700 Second St, Ste G
Encinitas, CA 92024
U.S.A.
Tel.: 1 760 634-7740
Fax: 1 760 634-7746

Firm Proposal

Page: 2 of 2

CLICK FOR MORE INFORMATION ON ALL THE SWEDE SURVIVAL PRODUCTS

http://www.draeger.com/sites/enus_us/Pages/Fire-Services/Swede-Survival.aspx?navID=369



TERMS & CONDITIONS:

1. Site preparation, i.e Concrete pad, and additional space to stage responsibility of customer
2. Off-load, staging, and final set-up to be the responsibility of customer
3. Equipment needed for set-up furnished by customer
4. Any building permits and/or trade licenses by customer and are not included
5. Taxes not included (unless requested by customer)
6. Freight only valid for 30 days
7. Training is a mandatory part of the scope of delivery and has to take place within 30 days of the set-up of the system
8. Draeger holds the right to adjust the sales price of Line Item A, if training is to take place outside the NAFTA area
9. System is not to be used with untrained operators/instructors

Total Project Costs: \$47,500.00

Notes

-- MFR std (1) year warranty applicable

-

Authorized Signature: *Dominic Colletti*

Name: Dominic Colletti
Title: Regional Manager, East
Mobile: 215-872-5626
Email: Dominic.Colletti@draeger.com

Confidential and Proprietary
No release without written authorization from Dräger



Swede Survival Systems

Phone - (760) 634-7740 FAX - (760) 634-7746

FLASHOVER CONTAINER ASSEMBLY AND SET UP INSTRUCTIONS

The Flashover Container System has been built to the exacting specifications of Draeger Swede Systems, Inc. Years of research have gone into the design and modifications of the containers. Please follow the instructions carefully and they will save time and effort.

SITE REQUIREMENT

A Level pad of either concrete or gravel with average dimensions of not less than 20' wide and 40' long (800 sq ft.) No foundation or drainage system is required.

CRANE or FORKLIFT REQUIREMENT

Large capacity forklift with extended arms (8 ft blades) that can handle 20,000 lbs, or a crane. Set up time is approximately 2 hours for 2 people (forklift operator +1)

1) Select a site that will allow for water drainage and positioning of fire apparatus if applicable. Decomposed granite, asphalt, and cement are ideal surfaces. If soil conditions do not lend themselves to a clean operation, you may want to consider having gravel or decomposed granite brought in as a base.

2) Consider smoke travel and wind direction in your placement. If possible place upper container so that it faces into the prevailing wind.

3) Do not use concrete pavers provided to level or support containers. These have been provided to cover the floor of the upper container. They are for protection from the severe heat generated in this area. Level the 20' observation container. These pavers will already be installed.

4) Remove screws installed to keep side doors secure during transport. Save for possible later use.

5) Hook the burn container to the lower observation container by the hooks provided.

6) The angle iron or flat stock steel provided should be spot welded onto the containers, once they are attached at the top and sides. This will make the system tighter and not allow oxygen to enter at these points. This will also alleviate the expansion and contraction that takes place during evolutions. We send 1- 8" piece of angle iron (for the top), and 2-6" pieces of flat stock steel for the sides. Please refer to the included diagram for additional information.

7) After the two containers have been attached, use the two jacks provided to support the rear of the upper container. Some type of footing may be necessary to keep the jacks from sinking into the ground.

8) Fireblock foam should be used to fill any small holes or daylight that may appear when inside the system after welding. This can be purchased at any Home Depot. Example name brand is - DAP Polyurethane Fireblock Foam Sealant.

9) The chimney for the vent should be lifted to the roof of the observation container and attached to the protruding lip and secured using the bolts provided. The cable for vent operation should be threaded through the guide pulleys and attached to the vent damper. All hardware is provided. Check to see that the pulley and damper operate freely.

TOP FIELD VIEW PROVIDED ABOVE FROM/OIL FURT STOCK TO TOP OF OBSERVATION BOX

PHASE 1

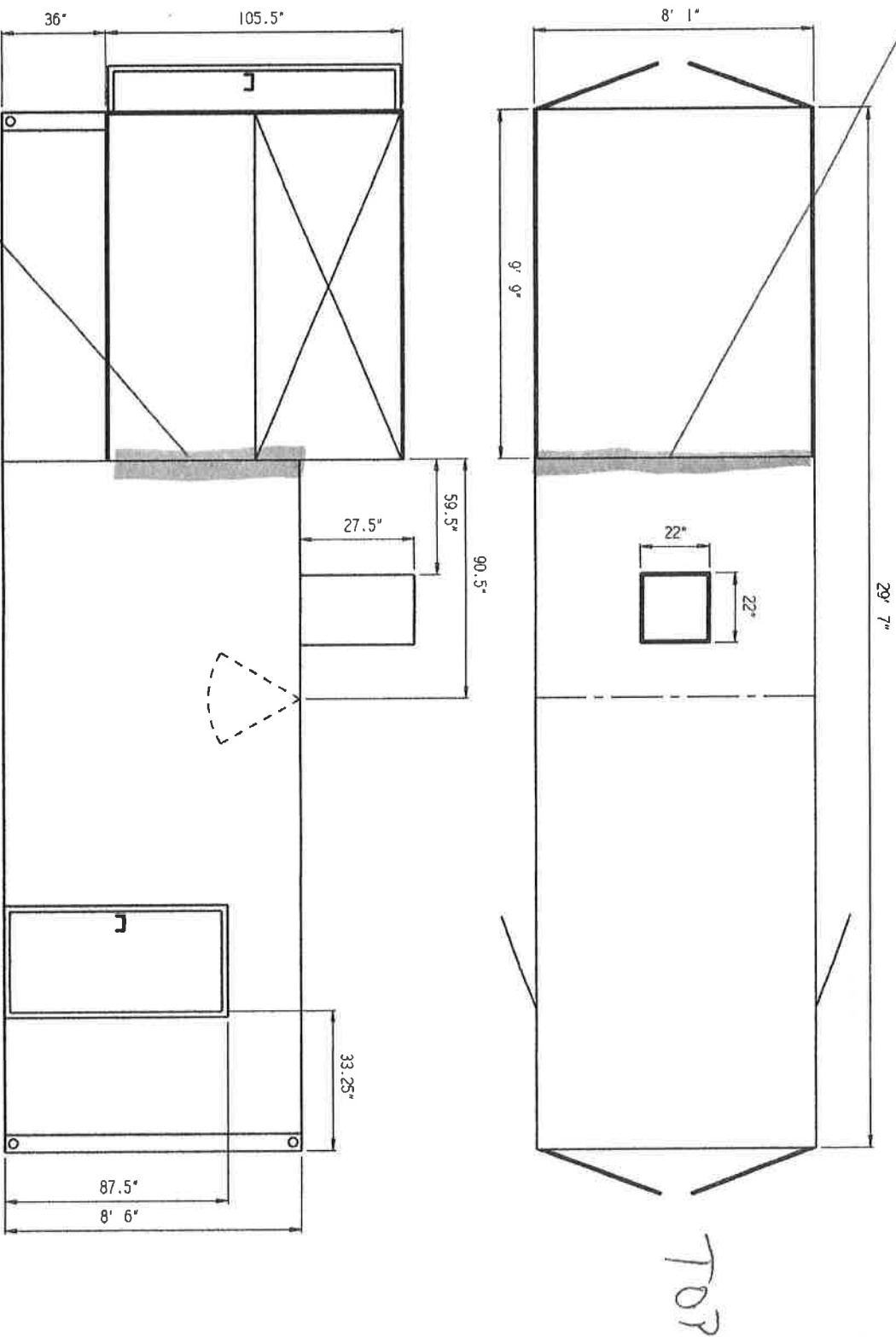

BOTH SIDES: FIELD VIEW 2" X 3/16" FLAT STEEL (APPROX 62") AFTER CONNECTING THE BURN BOX TO THE OBSERVATION BOX

SWEDE SURVIVAL SYSTEMS PHASE 1

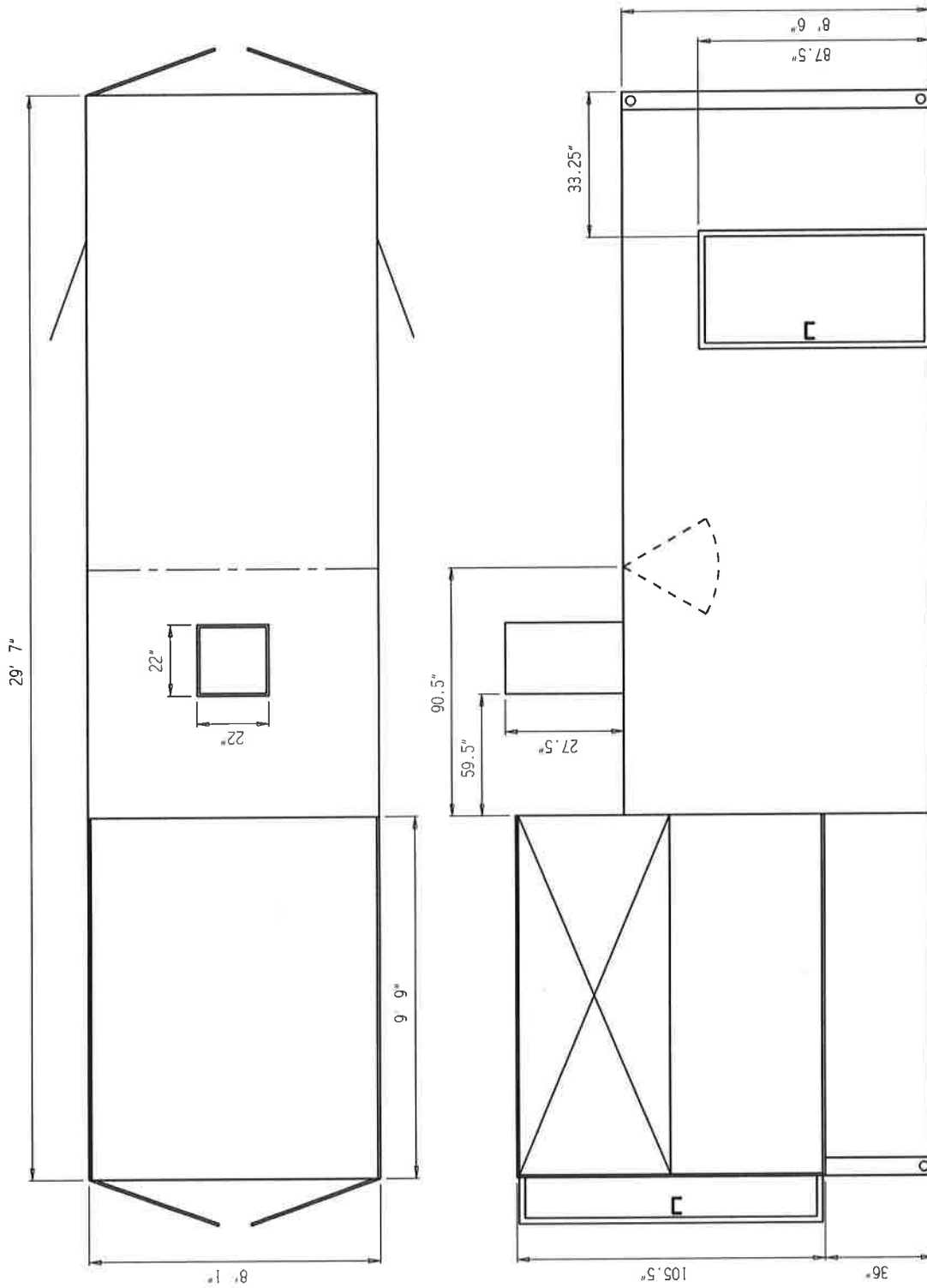

Dräger

PHASE I
CONFIDENTIAL

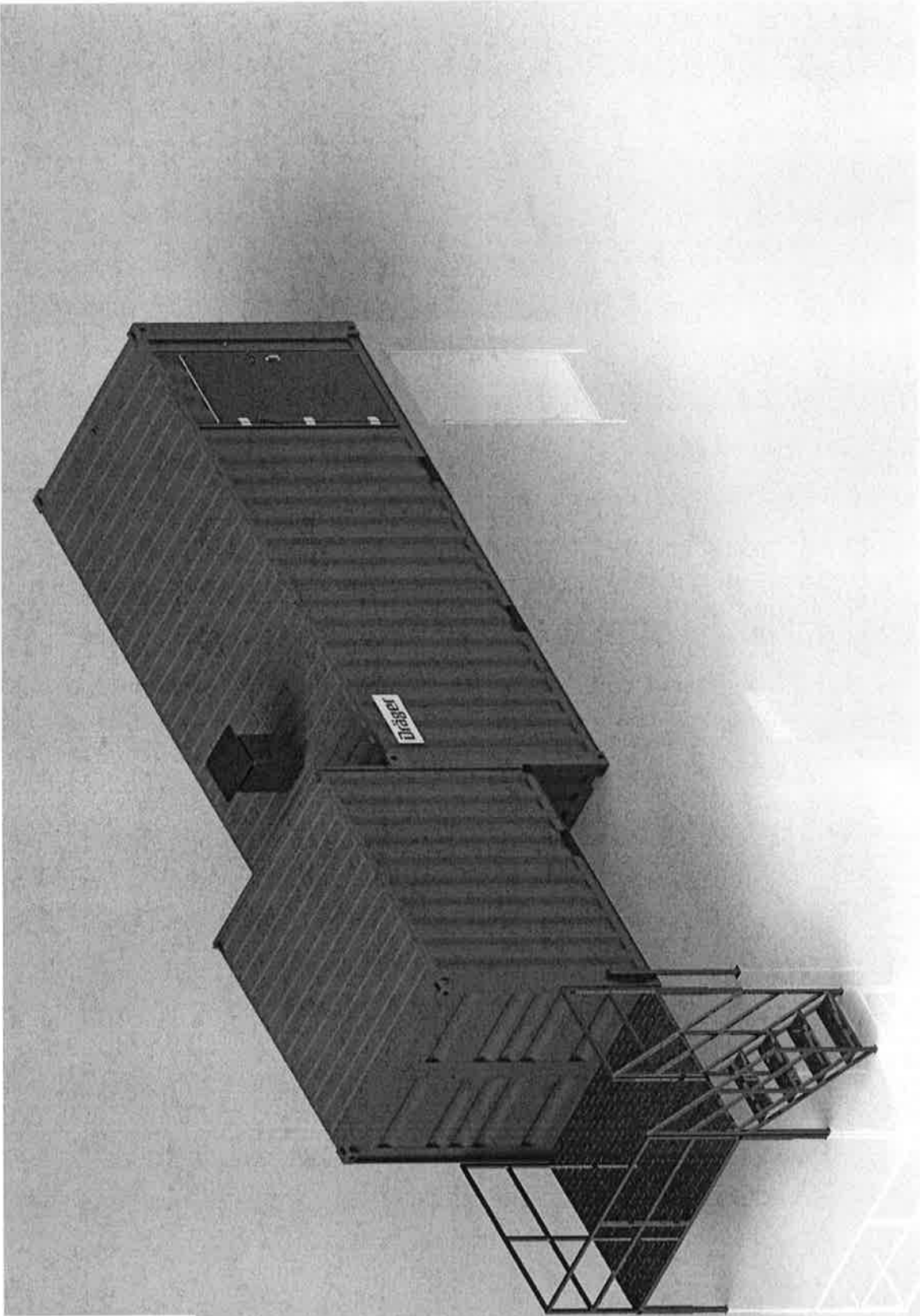

Dräger

PHASE I
CONFIDENTIAL

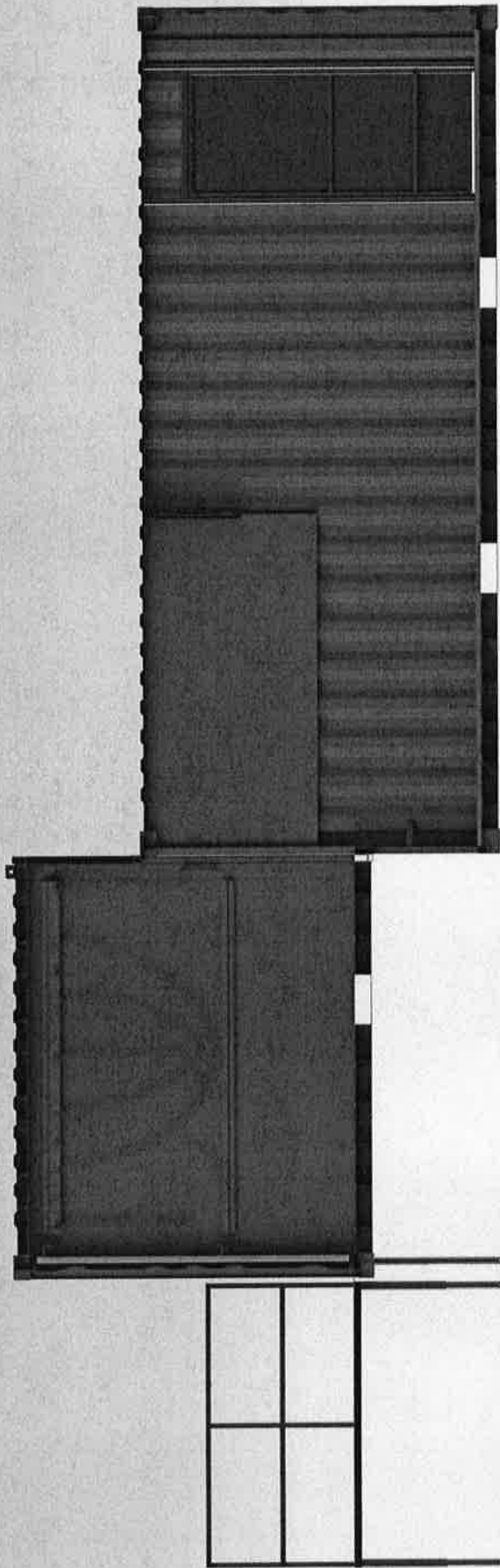

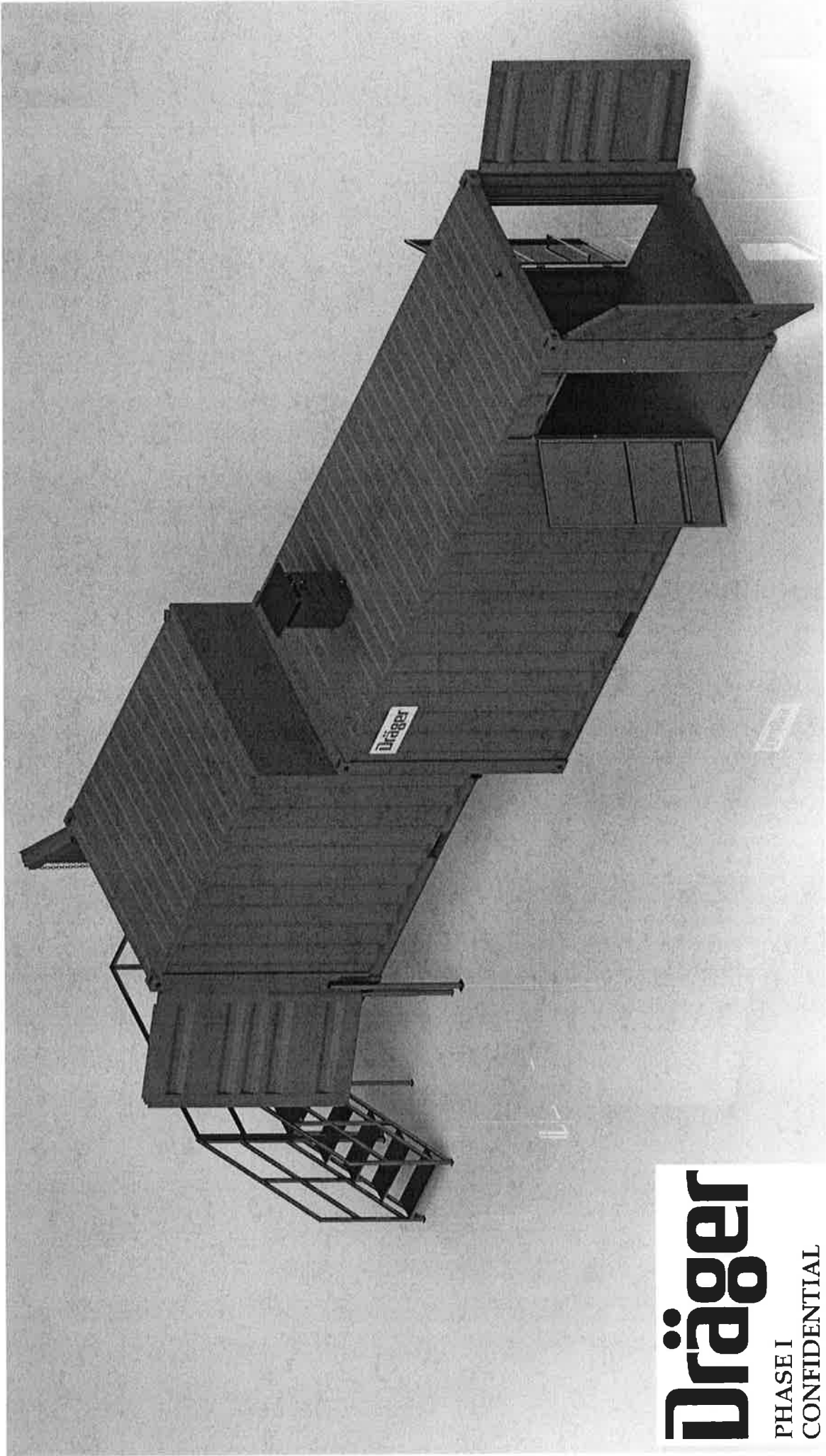

Dräger

PHASE I
CONFIDENTIAL

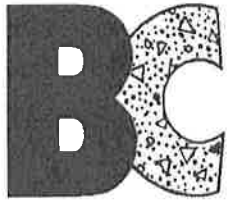

BAIRD CONCRETE CORPORATION

P. O. Box 5817 Fredericksburg, VA 22403

Phone: (540) 373-8686 Fax: (540) 373-8725

PROPOSAL/CONTRACT

(2 pages)

Date: February 11, 2016

To: Spotsylvania County Department of Fire, Rescue & Emergency Management
Attn: Jeff Bailey (JBailey@Spotsylvaia.va.us)

From: David Servais, Senior Estimator

Project: Rappahannock Regional Fire Rescue Training Center
12901 Trench Hill Lane
Fredericksburg, VA 22407

The following price is submitted for the above-referenced job:

Site Concrete Pad 20'x40':

Furnish and install 4" #57 stone base

Furnish, pour, and finish 4" concrete with 2.1wwm (800 SF)

Total Amount \$4,400.00

Baird Inclusions:

1. 4000psi concrete, labor, #57 stone, forms and curing compound.
2. Work guaranteed against defects in materials and workmanship.
3. Prices are good for 30 days from the date of this proposal. This proposal shall be included in any contract for this project.

Baird Exclusions:

1. Sub-grade.
2. Engineering, compaction, backfill and testing.
3. Liability for damage to our work caused by others.
4. Responsibility for any underground utilities that are not located by others.
5. All caulking and sealants.
6. All demolition.
7. All signage and traffic control.
8. Baird Concrete Corp. does not accept responsibility for settlement of the sub-grade.
9. Cold weather concrete additives or cold weather protection.
10. Baird Concrete accepts AIA contracts or equal, Purchase Order, or this signed proposal/contract.

This proposal is for informational purposes only.

TERMS: Payment due upon receipt of invoice.

Unpaid amount is subject to 2% per month (24% per annum) service charge.

Acceptance of Proposal/Contract for:

**Rappahannock Regional Fire Rescue Training Center
12901 Trench Hill Lane
Fredericksburg, VA 22407**

**SPOTSYLVANIA COUNTY DEPARTMENT
OF FIRE, RESCUE & EMERGENCY**

Contractor (Firm Name)

BAIRD CONCRETE CORP.

Subcontractor (Firm Name)

Date: _____

Date: _____

By: _____
(Signature of authorized representative)

By: _____
(Signature of authorized representative)

(Type or print signer's name and title)

David Servais, Senior Estimator

(Type or print signer's name and title)

County of Spotsylvania
Founded 1721

Board of Supervisors

Greg Benton
Greg Cebula
Timothy J. McLaughlin
David Ross
Gary F. Skinner
Paul D. Trampe
Chris Yakabouski



Service, Integrity, Pride

Department of Finance

Annette D'Alessandro
Grants Manager
P.O. Box 215
8800 Courthouse Rd.
Spotsylvania, VA 22553
Phone: (540)507-7595
Fax: (540)582-6304

February 25, 2016

Theresa Hunter
Grants and Local Aid Manager
Virginia Department of Fire Programs
Attn: Regional Fire Services Training Grant Administration
1005 Technology Park Drive
Glen Allen, VA 23059-4500

Dear Ms. Hunter,

Please find attached the necessary documents for the 2016 Regional Fire Services Training Facilities Grant Application for the Rappahannock Regional Fire Training Center for the purchase of a flashover simulator.

If you require any additional information, please do not hesitate to contact Lieutenant Stephen Wise at (540) 507-7921 spwise@spotsylvania.va.us

Sincerely,

Annette D'Alessandro

enclosures

Department of Fire Programs

FEB 29 2016

Administration



General Instructions & Notices

- Applicants are directed to "**Regional Fire Services Training Facilities Grant Program Policy**" as amended for the current funding year which is incorporated by reference to all applications and any subsequent awards. (Such practices document is inclusive of all *terms & conditions*.)
- The filing of an application does not bind the Board to award nor the Department to pay any such grant.
- Incomplete applications and those received after the deadline will not be considered.
(Deadline) → **March 1, 2016** *postmarked*
- Completed applications executed by the competent authority will only be accepted directly from jurisdictions not fire departments.
- Timeliness of filing and subsequent receipt by the Agency are solely the applicant's responsibility – all applications must be completed in ink and sent directly to: **VDFP Grants and Local Aid Manager,**
Address → 1005 Technology Park Drive, Glen Allen VA 23059-4500
- All decisions regarding grant awards made by the Board are final; applicants may appeal decisions in writing to the address provided above within 15 business days of the posting of awards.

A. Applicant Information

1. Title of Lead Jurisdiction Making Application (Check <input checked="" type="checkbox"/> only one, then make entry)	<input checked="" type="checkbox"/> County of Bedford
	<input type="checkbox"/> City of _____
	<input type="checkbox"/> Incorporated Town of _____
2. Employer Identification Number (EIN)	[REDACTED]
3. Principal Point of Contact	(Include salutation, name & title) Seth Mowles, Deputy Fire Chief
4. Mailing Address (Include zip code) Identify COUNTY if appropriate	1185 Turning Point Rd Bedford, Va 24523 Bedford County
5. Telephone Number	(540) 587-0700
6. FAX Number	(540-) 586-2176
7. Internet e-mail address	s.mowles@bedfordcountyva.gov

B. Additional Parties

	Identify ALL jurisdictions (Not Fire Departments) participating in the proposed project. Attach additional sheets as may be required.
1. Formal Agreement Among Parties	In accordance with Program Policy, multi-jurisdictional regional training partnerships must be documented (e.g. MOA, MOU, etc.) as required supporting documentation to the Application for consideration of Program funding. A copy of the Agreement has been attached to this application. <input checked="" type="checkbox"/> Yes <input type="checkbox"/> No <i>If a copy of the Agreement has not been attached as required supporting documentation, this Application will be considered incomplete and funding will not be approved.</i>

Department of Fire Programs

MAR 04 2016

Administration

MAR 04 2016

ATTACHMENT A



Commonwealth of Virginia
Department of Fire Programs

Virginia Fire Services Board
FY-2016 Regional Fire Services Training Facilities Grant Application

Administration

{ Reproduce and complete as many additional blocs as may be necessary for complete disclosure. }

2a. Complete <u>one each</u> for ALL other Parties of Interest	Number <input type="text" value="2"/> of a total of <input type="text" value="2"/> parties to proposed project <small>(Count the LEAD Locality as #1, thereby start with #2.)</small>
2b. Title of Jurisdiction <small>(Check <input checked="" type="checkbox"/> only one, then make entry)</small>	County of _____ City of _____ <input checked="" type="checkbox"/> Incorporated Town of <u>Bedford</u>
2c. Employer Identification Number (EIN)	_____
2d. Principal Point of Contact <small>(Include salutation, name & title.)</small>	Brad Creasy, Fire Chief
2e. Mailing Address <small>(Include zip code+4)</small> <small>Identify COUNTY if appropriate</small>	315 Bedford Ave Bedford, Va 24523
2f. Telephone Number	(540) 586-3433
2g. FAX Number	()
2h. Internet e-mail address	bcreasy@bedfordva.gov

{ Reproduce and complete as many additional blocs as may be necessary for complete disclosure. }

2a. Complete <u>one each</u> for ALL other Parties of Interest	Number <input type="text"/> of a total of <input type="text"/> parties to proposed project <small>(Count the LEAD Locality as #1, thereby start with #2.)</small>
2b. Title of Jurisdiction <small>(Check <input type="checkbox"/> only one, then make entry)</small>	County of _____ City of _____ Incorporated Town of _____
2c. Employer Identification Number (EIN)	_____
2d. Principal Point of Contact <small>(Include salutation, name & title.)</small>	
2e. Mailing Address <small>(Include zip code+4)</small> <small>Identify COUNTY if appropriate</small>	
2f. Telephone Number	()
2g. FAX Number	()
2h. Internet e-mail address	

{ Reproduce and complete as many additional blocs as may be necessary for complete disclosure. }

2a. Complete <u>one each</u> for ALL other Parties of Interest	Number <input type="text"/> of a total of <input type="text"/> parties to proposed project <small>(Count the LEAD Locality as #1, thereby start with #2.)</small>
2b. Title of Jurisdiction <small>(Check <input type="checkbox"/> only one, then make entry)</small>	County of _____ City of _____ Incorporated Town of _____
2c. Employer Identification Number (EIN)	_____
2d. Principal Point of Contact <small>(Include salutation, name & title.)</small>	
2e. Mailing Address <small>(Include zip code+4)</small> <small>Identify COUNTY if appropriate</small>	
2f. Telephone Number	()
2g. FAX Number	()
2h. Internet e-mail address	



C. Previous Applications/Awards

1.	Has the Applicant previously applied for a RFSTF Grant from the Board? - check <input checked="" type="checkbox"/> one	<input checked="" type="checkbox"/> No	<input type="checkbox"/> Yes
2.	Has the Applicant previously received a RFSTF Grant from the Board? - check <input checked="" type="checkbox"/> one	<input checked="" type="checkbox"/> No	<input type="checkbox"/> Yes

D. Project Title(s) and Description(s)

Enter a descriptive 'Title' and brief 'Description' for the lead training project and/or program proposed for funding from any Grant which may be awarded pursuant to this application.

1	SCBA Maze Simulator	Bedford County is currently seeking funding to assist with the building of an SCBA Maze Training Prop that will be located on our training grounds. We will be purchasing the connex container and are requesting the building materials to complete the project.
Which statement best describes the above proposed project and/or program? <i>check <input checked="" type="checkbox"/> one</i>		
<input checked="" type="checkbox"/> New <input type="checkbox"/> Change to existing <input type="checkbox"/> Continuing		
Which statement best describes how many training programs may benefit from the proposal? <i>check <input checked="" type="checkbox"/> one</i>		
<input checked="" type="checkbox"/> Multiple Programs <input type="checkbox"/> Single Program		
Describe the impact on training if this Grant is not awarded, or check <input checked="" type="checkbox"/> No Significant Impact		
This training Prop will be able to be utilized by any entity utilizing our training grounds. The Training Facility is used by Fire and Rescue Agencies, Law Enforcement agencies, Dog Area search teams, Other localities that have used our training facility include RoanokeCity, Roanoke County, Salem, Botetourt, Campbell and Amherst Counties.		
<input type="checkbox"/> ← Check <input checked="" type="checkbox"/> IF a Continuation D Sheet is used to account for more than one (1) project / program. IMPORTANT, if box above is checked and no continuation sheets are attached, the application will not be further considered.		

Department of Fire Programs
 Administration
 MAR 04 2016

E. Project Goods & Services Requested

In the below table, itemize in priority order – starting with the most needed first, ALL items of "Goods" (e.g. equipment, hardware or other durable items) or categories of "Services" which are to be funded in whole or in part from any Grant which may be awarded pursuant to this application.

Enter Project Title from [D] above	Check <input checked="" type="checkbox"/> One	Description	Total Cost	Less any Matching Funds	Grant Amount Requested
1	<input checked="" type="checkbox"/> Goods <input type="checkbox"/> Services	SCBA Maze Simulator will be built on the Bedford Area training facility. The Connex container will be purchased by Bedford County and we are requesting funding for the raw materials to build the SCBA Maze.	(a) \$ 18,000.00	(b) \$ 4,000.00	(a-b) \$ 14,000.00
2	<input type="checkbox"/> Goods <input type="checkbox"/> Services		(a) \$ -	(b) \$ -	(a-b) \$ -
3	<input type="checkbox"/> Goods <input type="checkbox"/> Services		(a) \$ -	(b) \$ -	(a-b) \$ -
4	<input type="checkbox"/> Goods <input type="checkbox"/> Services		(a) \$ -	(b) \$ -	(a-b) \$ -
5	<input type="checkbox"/> Goods <input type="checkbox"/> Services		(a) \$ -	(b) \$ -	(a-b) \$ -

← Check IF a Continuation D Sheet is used to account for **more than one (1) project / program.**
IMPORTANT, if box above is checked and no continuation sheets are attached, the application will not be further considered.

E	Enter here the lesser amount of:	\$ 14,000.00
	<ul style="list-style-type: none"> • Sum of <u>all</u> items (1 thru n) under "Grant Amount Requested" • OR \$50,000 (<i>Grant maximum</i>) 	



F. Matching/Cost Share

1	Which statement best describes the matching funds contributions? <i>check <input checked="" type="checkbox"/> one</i>	<input type="checkbox"/> 50% or More	<input checked="" type="checkbox"/> Less than 50%	<input type="checkbox"/> None
---	--	--------------------------------------	---	-------------------------------

G. ATL Funding

1	What is the amount of the Applicant's FY-2015 Aid to Localities (ATL) allocation from the Fire Programs Fund? <i>check <input checked="" type="checkbox"/> one and complete as necessary</i>	<input type="checkbox"/> \$10,000 or \$20,000 exactly	<input checked="" type="checkbox"/> Other - Enter amount here	\$ 250,185.00
2	Did the Applicant have cash carry forward from FY-2015 into FY-2016 from previous years' Aid to Localities (ATL) allocations? <i>check <input checked="" type="checkbox"/> one and complete as necessary</i>	<input checked="" type="checkbox"/> Yes	<input type="checkbox"/> No	If "Yes", amount of FY-2015 ATL carry forward: \$ 59,573.81

Remarks	Make entries or check <input checked="" type="checkbox"/> <input type="checkbox"/> None	Important - If the sum (1 to n) of individual "Grant Amount Requested" in E above exceeded \$50,000, an explanation must be entered here as to how the shortfall would otherwise be made up.
	This sum of #1 is what Bedford County received in FY2015. We then distribute the ATL funds to the agencies within our locality.	
	The FY2016 carry over funds have been utilized. We have purchased the connex containers to have the SCBA prop built in. We need the material costs of building the prop within the connex container.	

Administration

MAR 04 2016

Department of Fire Programs

EFT (EDI)

Grant awards are paid as an **Electronic Funds Transfer / EDI** to the current *account-of-record* for the jurisdiction's annual allocation of Aid to Localities (ATL) from the Fire Programs Fund.

Certification:

To be completed by either:

- County Administrator –or- Executive, City Manager, Town Mayor –or- Administrator; Deputy, or...
- Other duly authorized official whereby the application is accompanied by a copy of an 'Ordinance' or other such formal instrument clearly granting that party such authority.

This grant application is entered on behalf of the APPLICANT jurisdiction identified above with the knowledge and belief that all representations herein made are true and correct; with the understanding that all grant terms & conditions in-force as of the date of such application are hereby included by reference; with the further understanding that if an award is granted pursuant to this application that the recipient is bound by those same terms & conditions.

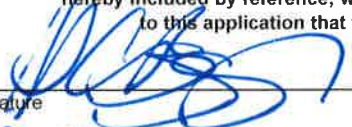
Signature 	Date 01 March 2016
Printed Name G. CARL BOGGS	Title County Administrator

(All applications must be notarized to be considered - Incomplete forms shall be returned.)

State of Virginia }
 City / County of Bedford }

On this 1 day of March (month) in 2016 (year), before me, the undersigned a Notary Public for the Commonwealth of Virginia, personally appeared G. Carl Boggs to me known (or to me proved) to be the identical person named herein and having in my presence executed the above, and acknowledged that he executed same as his voluntary act and deed.

My Commission expires: 9-30-2018 Date Nicole McCabe Notary Public

Nicole McCabe
 (Seal) Notary Public
 Commonwealth of Virginia
 ID #263493
 My Commission Exp.: 9-30-2018

Continuation Sheet D - Side 1

D	<i>Enter a descriptive 'Title' and brief Description for the lead training project ^{and} /or program proposed for funding from any Grant which may be awarded pursuant to this application.</i>	
2	(Title)	(Description)
	Which statement best describes the above proposed project and/or program? <i>check <input checked="" type="checkbox"/> one</i>	
	<input type="checkbox"/> New	<input type="checkbox"/> Change to existing <input type="checkbox"/> Continuing
	Which statement best describes how many <u>training programs</u> may benefit from the proposal? <i>check <input checked="" type="checkbox"/> one</i>	
	<input type="checkbox"/> Multiple Programs	<input type="checkbox"/> Single Program
	Describe the impact on training if this Grant is not awarded, or check <input checked="" type="checkbox"/>	
		No Significant Impact

Administration

MAR 04 2016

Department of Family Programs

D	<i>Enter a descriptive 'Title' and brief Description for the lead training project ^{and} /or program proposed for funding from any Grant which may be awarded pursuant to this application.</i>	
3	(Title)	(Description)
	Which statement best describes the above proposed project and/or program? <i>check <input checked="" type="checkbox"/> one</i>	
	<input type="checkbox"/> New	<input type="checkbox"/> Change to existing <input type="checkbox"/> Continuing
	Which statement best describes how many <u>training programs</u> may benefit from the proposal? <i>check <input checked="" type="checkbox"/> one</i>	
	<input type="checkbox"/> Multiple Programs	<input type="checkbox"/> Single Program
	Describe the impact on training if this Grant is not awarded, or check <input checked="" type="checkbox"/>	
		No Significant Impact

D	<i>Enter a descriptive 'Title' and brief Description for the lead training project ^{and} /or program proposed for funding from any Grant which may be awarded pursuant to this application.</i>	
4	(Title)	(Description)
	Which statement best describes the above proposed project and/or program? <i>check <input checked="" type="checkbox"/> one</i>	
	<input type="checkbox"/> New	<input type="checkbox"/> Change to existing <input type="checkbox"/> Continuing
	Which statement best describes how many <u>training programs</u> may benefit from the proposal? <i>check <input checked="" type="checkbox"/> one</i>	
	<input type="checkbox"/> Multiple Programs	<input type="checkbox"/> Single Program
	Describe the impact on training if this Grant is not awarded, or check <input checked="" type="checkbox"/>	
		No Significant Impact

Be sure that if this continuation work sheet is used, your application is both properly marked and this sheet is included with your application filing.

Continuation Sheet D - Side 2

D	Enter a descriptive 'Title' and brief Description for the lead training project ^{and/or} program proposed for funding from any Grant which may be awarded pursuant to this application.	
5	(Title)	(Description)
	Which statement best describes the above proposed project and/or program? check <input checked="" type="checkbox"/> one	
	<input type="checkbox"/> New	<input type="checkbox"/> Change to existing <input type="checkbox"/> Continuing
	Which statement best describes how many training programs may benefit from the proposal? check <input checked="" type="checkbox"/> one	
	<input type="checkbox"/> Multiple Programs	<input type="checkbox"/> Single Program
	Describe the impact on training if this Grant is not awarded, or check <input checked="" type="checkbox"/>	
		No Significant Impact

D	Enter a descriptive 'Title' and brief Description for the lead training project ^{and/or} program proposed for funding from any Grant which may be awarded pursuant to this application.	
6	(Title)	(Description)
	Which statement best describes the above proposed project and/or program? check <input checked="" type="checkbox"/> one	
	<input type="checkbox"/> New	<input type="checkbox"/> Change to existing <input type="checkbox"/> Continuing
	Which statement best describes how many training programs may benefit from the proposal? check <input checked="" type="checkbox"/> one	
	<input type="checkbox"/> Multiple Programs	<input type="checkbox"/> Single Program
	Describe the impact on training if this Grant is not awarded, or check <input checked="" type="checkbox"/>	
		No Significant Impact

D	Enter a descriptive 'Title' and brief Description for the lead training project ^{and/or} program proposed for funding from any Grant which may be awarded pursuant to this application.	
7	(Title)	(Description)
	Which statement best describes the above proposed project and/or program? check <input checked="" type="checkbox"/> one	
	<input type="checkbox"/> New	<input type="checkbox"/> Change to existing <input type="checkbox"/> Continuing
	Which statement best describes how many training programs may benefit from the proposal? check <input checked="" type="checkbox"/> one	
	<input type="checkbox"/> Multiple Programs	<input type="checkbox"/> Single Program
	Describe the impact on training if this Grant is not awarded, or check <input checked="" type="checkbox"/>	
		No Significant Impact

Be sure that if this continuation work sheet is used, your application is both properly marked and this sheet is included with your application filing.

MAR 04 2003

Department of Fire Programs

Administration

MAR 04 2016

Continuation Sheet E - Side 1

Administration

E In the below table itemize in priority order – starting with the most needed first, **ALL** items of "Goods" (e.g. equipment, hardware or other durable items) or categories of "Services" which are to be funded in whole or in part from any Grant which may be awarded pursuant to this application.

Enter Project Number from [D] above	Check <input checked="" type="checkbox"/> One	Description	Total Cost	Less any Matching Funds	Grant Amount Requested
6	<input type="checkbox"/> Goods		(a)	(b)	(a-b)
	<input type="checkbox"/> Services		\$ -	\$ -	\$ -
7	<input type="checkbox"/> Goods		(a)	(b)	(a-b)
	<input type="checkbox"/> Services		\$ -	\$ -	\$ -
8	<input type="checkbox"/> Goods		(a)	(b)	(a-b)
	<input type="checkbox"/> Services		\$ -	\$ -	\$ -
9	<input type="checkbox"/> Goods		(a)	(b)	(a-b)
	<input type="checkbox"/> Services		\$ -	\$ -	\$ -
10	<input type="checkbox"/> Goods		(a)	(b)	(a-b)
	<input type="checkbox"/> Services		\$ -	\$ -	\$ -
11	<input type="checkbox"/> Goods		(a)	(b)	(a-b)
	<input type="checkbox"/> Services		\$ -	\$ -	\$ -
12	<input type="checkbox"/> Goods		(a)	(b)	(a-b)
	<input type="checkbox"/> Services		\$ -	\$ -	\$ -

Be sure that the total of ALL "Grant Amount Requested" entries are properly accounted for in the final line of Section E of your application. Also, be sure that if this continuation work sheet is used, your application is both properly marked and this sheet is included with your filing of the application.

Continuation Sheet E - Side 2

	<input type="checkbox"/> Goods		(a)	(b)	(a-b)
--	--------------------------------	--	-----	-----	-------

13		<input type="checkbox"/> Services		\$ -	\$ -	\$ -
14		<input type="checkbox"/> Goods		(a)	(b)	(a-b)
		<input type="checkbox"/> Services		\$ -	\$ -	\$ -
15		<input type="checkbox"/> Goods		(a)	(b)	(a-b)
		<input type="checkbox"/> Services		\$ -	\$ -	\$ -
16		<input type="checkbox"/> Goods		(a)	(b)	(a-b)
		<input type="checkbox"/> Services		\$ -	\$ -	\$ -
17		<input type="checkbox"/> Goods		(a)	(b)	(a-b)
		<input type="checkbox"/> Services		\$ -	\$ -	\$ -
18		<input type="checkbox"/> Goods		(a)	(b)	(a-b)
		<input type="checkbox"/> Services		\$ -	\$ -	\$ -
19		<input type="checkbox"/> Goods		(a)	(b)	(a-b)
		<input type="checkbox"/> Services		\$ -	\$ -	\$ -
20		<input type="checkbox"/> Goods		(a)	(b)	(a-b)
		<input type="checkbox"/> Services		\$ -	\$ -	\$ -
21		<input type="checkbox"/> Goods		(a)	(b)	(a-b)
		<input type="checkbox"/> Services		\$ -	\$ -	\$ -

Be sure that the total of ALL "Grant Amount Requested" entries are properly accounted for in the final line of Section E of your application. Also, be sure that if this continuation work sheet is used, your application is both properly marked and this sheet is included with your filing of the application.



Bedford County

DEPARTMENT OF FIRE & RESCUE



This grant request will be the items that will be included in the building of the props. The \$14,000.00 grant request will include:

Supplies to build 13 modular props that will be 32"W x 48"H x 8'L.
These props will be movable to prevent memorization of the course.
These props will include teeter totter, V-floor, Trusses, Spongy floor, Diminished width, and many more.

VIRGINIA FIRE SERVICE GRANT PROGRAM AGREEMENT

Regional Fire Services Training Facilities

Statutory Authority: §38.2-401 of the *Code of Virginia*

This Grant Agreement, made as of the 28th day of February, by and among the VIRGINIA DEPARTMENT OF FIRE PROGRAMS (the "Department"), acting as authorized on behalf of the Virginia Fire Services Board (the "Board"), and Bedford County, (the "Grantee"), governs the distribution and use of Fire Services Grant Program moneys, as provided for in §38.2-401 (D) of the *Code of Virginia*.

WHEREAS, §38.2-401 (D) of the *Code of Virginia*, authorizes the Board to determine the distribution of grants to provide regional fire services training facilities; to finance the Virginia Fire Incident Reporting System; and to build or repair Burn Buildings; and

WHEREAS, the Grantee has submitted an application for a grant from the Fire Services Grant Fund Program to assist in funding a Regional Fire Services Training Facilities project together with plans, specifications, and project narrative for such project, more specifically described in Attachment A hereto (the "Project"); and

WHEREAS, the Board has approved the Project and has authorized the Department to act on its behalf in the distribution and administration of grants;

NOW, THEREFORE, pursuant to the authority granted to the Board and Department by §38.2-401 (D) of the *Code of Virginia*, and in consideration of the Grantee's adoption and ratification of the representations, terms and conditions as herein provided, and benefits to accrue to the Commonwealth and public from the accomplishment of this Project, the department offers a grant of \$ 14,000.00 to pay eligible Project cost subject to the terms and conditions listed below:

- 1 These funds shall be disbursed by the Department to the Grantee after the Agreement has been signed, on reimbursement basis of qualifying Project expenses.
- 2 Unless an extension has been granted by the Department, grant performance shall be completed, and all documentation pertaining to such activities shall be submitted to the Department on or before 12 months after the grant funds have been disbursed.
- 4 The Department may grant an extension of up to three months beyond the 12-month period to perform the grant project, and to submit documentation. Any extension beyond three months must be submitted to the Virginia Fire Services Board for approval.
- 5 The Grantee agrees to carry out and complete all phases of the Project strictly in accordance with the plans, specifications and project narrative. The plans, specifications and project narrative may only be revised or modified with the Board or Department's prior written approval. The Grantee agrees to allow the Board representative access to the Project at all reasonable times to verify compliance with the approved plans, specifications and project narrative.

Department of Fire Programs

MAR 04 2016

6 The Grantee agrees that no Project performance shall commence until the following types of insurance are in place for entities performing any such work, including subcontractors, and these types of insurance shall be maintained at all times while construction or repair work is being performed: (a) an All Risk Builders Risk Property insurance policy based on the completed value of all such work, with exclusions for design errors or defects removed by policy endorsement, and the locality shall be named additional insured in such policy; (b) a Workers' Compensation and Employer's Liability insurance policy covering all workers or employees engaged in such work, and, in case any such work is sublet, each subcontractor shall, similarly, provide Workers' Compensation and Employer's Liability Insurance for all of the subcontractor's workers or employees who are engaged in the work, and in amounts not less than the minimums required by the Code of Virginia and other applicable laws and regulations;

(c) a Comprehensive Commercial General Liability insurance policy that provides a minimum level of \$500,000 combined single limit per occurrence, and the locality shall be named as an additional insured party in such policy; and (d) a Comprehensive Automobile Liability insurance policy that will insure against claims for property damage that may arise from the operation of motor vehicles associated with the construction or repair work, with a minimum level of \$500,000 combined single limit per occurrence. Before the commencement of any work, the locality must submit to the VDFP a Certificate of Coverage or Certificate of Insurance indicating that these types of insurance are in effect. All insurance shall be provided by insurers who are licensed to provide insurance in the Commonwealth of Virginia.

7 The Grantee agrees to operate and maintain the Project, now existing or built in whole or in part as a result of the Project, as a training facility for a period of 20 years from completion of this Project.

8 The Grantee agrees to operate, maintain and use the Project in accordance with the policies adopted by the Board, as amended from time to time.

9 Subject to lawful appropriation, the Grantee agrees to repay to the Department a sum which is equal to the pro-rata share (computed monthly) of all monies received under this Grant Agreement based on the period of operation and maintenance as specified in paragraph 7 above in the event that the Project ceases to be available for such specified training purposes prior to the expiration of such period, if such change in availability is due to an act or omission within the sole and direct control of the Grantee.

10 Grantee hereby agrees that the Project shall be maintained and operated at all times in a manner designed to prolong the useful life of the Project and that no condition will be allowed to exist that will, or is likely to, lead to a shorter than expected useful life for the Project. The Grantee further agrees to ensure appropriate encroachment factors of surrounding land for a period of 5 years from the completion date of the Project.

11 The Grantee represents to the Department that (a) its authorized representative whose signature appears below has read and understands the referenced provisions of the Code of Virginia and the Board's policy entitled "VFSB Regional Fire Services Training Facilities Policy: Fire Service Grant Program", adopted thereunder, as amended from time to time, which are hereby incorporated into this Grant Agreement by reference in its entirety; (b) it agrees to comply with all applicable provisions of the Code of Virginia, including if appropriate, the Virginia Public Procurement Act that governs construction of public facilities by private entities. (c) It is duly authorized to enter into this Grant Agreement and to perform its obligations hereunder and has taken all necessary action to authorize such execution and performance.

12 This grant will be fully liquidated in public benefits to the Commonwealth 20 years from the completion date of the Project and the Grantee shall have no further financial obligation to the Commonwealth under this Grant Agreement upon the expiration of such time.

13 To the extent permitted by law, the Grantee shall retain title to the Project and underlying land, and the Grantee shall not release or transfer title without first receiving written approval from the Board prior to such release, which approval shall not be unreasonably withheld.

14 The Grantee agrees to retain all books, records and other documents relative to expenditures of Grant Funds for five years from the completion date of the Project. The Board, the Department and/or State auditors shall have full access to and the right to audit any of these records during the above-referenced period.

15 The Department shall be bound hereunder only to the extent of the Fire Services Grant Funds available or which may hereafter become available for the purpose of this Grant Agreement.

16 This writing constitutes the entire Grant Agreement between the parties, supersedes any existing Agreement among the parties hereto relative to the matters contained herein, and may be modified only by written amendment executed by all parties.

17 This Agreement shall in all respects be governed by the laws of the Commonwealth of Virginia without regard to the legislative or judicial conflict of laws rules of any state.

18 If any provision of this Grant Agreement is determined to be invalid by a court of competent jurisdiction, it shall not render the remaining portions of this Grant Agreement void or unenforceable.

19 This Grant Agreement may be executed in several counterparts, each of which shall be an original and all of which together shall constitute but one and the same instrument.

20 When any written notice or report is required or may be given hereunder, it will be deemed sufficient if the party giving such notice, request, or report delivers the same to the other party by U.S. mail, postage prepaid, or by other superior mailing, or by hand delivery. All notices, request, demands or reports delivered by mail or by hand will be deemed to have been given when received by any party hereto at the following addresses:

Grantee: Such office or mailing address as stated on the Point of Contact Form attached hereto or to such other address of which the Grantee has notified the other parties hereto in writing.

Agency and Board: Virginia Department of Fire Programs
Attn: Regional Fire Services Training Facilities Grant Administration
1005 Technology Park Drive
Glen Allen VA 23059-4500

or to such other address of which the Department has notified the Grantee in writing.

Department of Fire Programs

MAR 04 2015

Administration

